

Installation, Operation and Maintenance Instructions



SUMP CLEANERS

ERIEZ WORLD HEADQUARTERS: 2200 ASBURY ROAD, ERIE, PA 16506-1402 U.S.A.
WORLD AUTHORITY IN SEPARATION TECHNOLOGIES

Introduction

This manual details the proper steps for installing, operating and maintaining Eriez Sump Cleaners.

Careful attention to these requirements will assure the most efficient and dependable performance of this equipment.

If there are any questions or comments about the manual, please call Eriez at 814-835-6000 for Sump Cleaner assistance.

 **CAUTION**

**Safety labels must be affixed to this product.
Should the safety label(s) be damaged, dislodged
or removed, contact Eriez for replacement.**

Table of Contents

ERIEZ SUMP CLEANERS

SUMP CLEANER	5
SAFETY INFORMATION.....	5
OPERATOR SAFETY AND CONVENIENCE FEATURES	6
Safety Features.....	6
Convenience Features.....	6
SUMP CLEANER WARRANTY	7
OPERATING TIPS.....	9
Operating Efficiency Tips	9
LP GAS MODELS OPERATION	10
LP GAS DUAL TANK MODELS OPERATION.....	12
LP GAS MAINTENANCE SCHEDULE.....	15
LP GAS SPARE PARTS LISTS	16
AIR-OPERATED MODELS OPERATION.....	20
STANDARD SAFETY FEATURES	20
OPERATION REQUIREMENTS: 60-90 PSI, 32-47 CFM, 1/2" ID AIR LINE REQUIRED	20
AIR VENTURI DUAL TANK OPERATION	22
AIR VENTURI SPARE PARTS LISTS	23
120V ELECTRIC MODELS OPERATION	29
120V DUAL TANK OPERATION	30
120V MAINTENANCE SCHEDULE	31
120V SPARE PARTS LISTS.....	32
3-PHASE ELECTRIC MODELS OPERATION	36
3-PHASE ELECTRIC DUAL TANK OPERATION.....	37
3-PHASE MAINTENANCE SCHEDULE	39
3-PHASE SPARE PARTS LISTS.....	40
MAINTENANCE	44
SUMP CLEANER TROUBLESHOOTING CHART	45



Table of Contents *(cont.)*

ERIEZ SUMP CLEANERS

ELECTRIC SUMP CLEANER 50 GAL. / 120V	47
SAFETY INFORMATION.....	47
Pressurization Safety Issues.....	48
Standard Safety Features	48
CONVENIENCE FEATURES	48
WARRANTY	48
ASSEMBLY	49
OPERATION.....	49
OPERATING TIPS.....	51
OPERATING EFFICIENCY TIPS	51
MAINTENANCE	52
MAINTENANCE SCHEDULE.....	53
SUMP CLEANER - ELECTRIC - 120 VOLT TROUBLESHOOTING CHART.....	53
SUMP CLEANER - ELECTRIC - 120 VOLT SPARE PARTS LIST.....	54
DRUM TOP SUMP CLEANER: MODEL 90-1020	56
ASSEMBLY	56
OPERATION.....	56



SUMP CLEANER

Safety Information

1. To avoid possible injury, read this manual for full operating instructions before operating this cleaner. Also see the pump manufacturer's manual provided with your cleaner.
2. Always block the wheels of the cleaner to prevent unintentional rolling. Even when empty, some models weigh more than 1,500 pounds. Accidental rolling could cause injury or property damage.
3. Wear eye goggles to protect your eyes from splashing liquids. This is important, even when you know the fluids themselves are not caustic or otherwise harmful. Metal particles suspended in the liquid could still cause serious eye injury.
4. Check hose, nozzle, cleaning tool and hose cap connections for leaks. To minimize chances of spilling, handle cleaning tools and hoses carefully during operation. Replace hoses before deterioration results in leaks.
5. Immediately clean up any spilled coolant to avoid slippery floors and dangerous falls.
6. If it is necessary to use the cleaner in an aisle or other traffic area, position it so as to minimize the likelihood of being struck by trucks, forklifts or other equipment in transit. Exercise a reasonable lookout for such hazards during operation.
7. Whenever removing or reseating the filter basket (maximum capacity is 800 pounds), keep hands and fingers out from under the basket lip.
8. Keep clear from beneath the basket when opening the trapdoor. Use tools of appropriate strength and length to let you perform these operations safely.
9. Frequently check the basket's hoisting rings for signs of rust. If the rings are heavily corroded, replace the basket with a new one.
10. Be sure the suction inlet ball valve is fully closed before operating the cleaner in the discharge mode. The tank is pressurized in this mode, sometimes to as much as 7 PSI.
11. After operating engine-driven units (LP gas or gasoline) in the discharge mode and before stopping engine, turn the suction/discharge lever to the suction position. The engine will "speed up" momentarily and then "slow down". When the engine has slowed down and begun to "labor", the engine switch may be turned OFF and the suction inlet ball valve opened.
12. Observe "NO SMOKING" rules when operating a gasoline or LP gas engine model. Operate only in adequately ventilated areas.
13. DO NOT use this unit for solvents, flammable (low flash point), or other volatile liquids. Use it only for water-soluble coolants and for cutting or grinding oils.
14. PRESSURIZATION SAFETY ISSUES. Your Sump Cleaner unit is designed to operate under pressure when discharging fluids. The optimal safe operating pressure is 5 to 7 PSI and your unit was set at the factory to operate in this range. Your unit should never be operated at pressures in excess of 15 PSI. Tanks or vessels which are pressurized beyond 15 PSI require special certification as "High Pressure Vessels" and this Sump Cleaner has not been certified for such high pressure operation. Operating a Sump Cleaner at pressures above 15 PSI creates a serious risk of injury to workers and damage to property.

WARNING

Altering or modifying safety regulating features may result in the tank becoming over pressurized. Over pressurization may cause the explosive rupture of the tank resulting in serious injury or death to workers and damage to property.

Modifying or intentionally altering these important safety features will constitute the intentional misuse of the equipment, voiding all warranties.

15. Temperature limit is 150°F (the limit of the suction and discharge hoses).
16. "Push-around" units (those equipped with large diameter wheels in the middle of the tank and swivel casters at both ends) are NOT designed for towing. If they must be moved long distances within a plant, pick up the unit with a forklift truck using the brackets provided on the sump cleaner.

17. This equipment is to be operated and maintained by authorized personnel only.
18. **MAGNESIUM CHIPS OR DISSIMILAR METALS**
In the presence of water, magnesium can release highly flammable hydrogen gas. In the proper proportions with air, it can be explosive. When a Sump Cleaner is used on a metalworking fluid application generating magnesium chips, certain precautions must be taken to ensure that any hydrogen gas is dissipated into the atmosphere and to make sure the hydrogen does not accumulate in the Sump Cleaner. This is accomplished by promptly removing any magnesium chips from the sump cleaner basket. Also, a maintenance schedule should be established by the customer that would eliminate buildup of sludge in the bottom of the Sump Cleaner. Finally, the unit should be stored in a clean condition with basket empty of chips, the sump cleaner tower lid removed, the coolant discharge nozzle(s) removed, and hoses opened to the atmosphere (on single and twin compartment units). Taking these precautions will minimize the risk of hydrogen gas generation and accumulation.

On an application where dissimilar metals are machined, there is a chance for spontaneous combustion to occur. Typically, metalworking facilities that machine various metals are aware of this and may have experienced problems in chip hoppers due to the presence of two or more metals, water, and tramp oil.

The precautions mentioned in the previous paragraph will minimize or eliminate the potential for spontaneous combustion.

19. The cleaner is to be adjusted and/or repaired only by qualified service personnel. If these personnel need more information than is provided in this manual, they should contact Eriez at 814-835-6000.

Operator Safety and Convenience Features

Safety Features

Although sump cleaners are inherently safe machines, they pose the potential for hand and finger injury when the operator removes the filter basket from the unit to empty it of chips and sludge. For this reason, Eriez has two safety features which are unique to their Sump Cleaners.

Filter basket safety guides automatically center the filter basket within the unit's basket support tower as it is being hoisted out of the machine. This eliminates the need for the operator to physically guide the heavy, full basket as it is being elevated and significantly reduces the opportunity for the operator to receive hand injuries.

Basket "trapdoor" release cables enable the operator to empty the filter basket (the basket can hold up to 800 pounds of chips) from a safe distance without the need for special tools. The basket is removed from the unit, positioned over a chip hopper or similar receptacle, and the contents are released through the basket bottom by the operator opening the trapdoor with a sharp pull on the release cable. During the entire operation, the operator is a safe distance away.

Convenience Features

Low rolling resistance, high maneuverability design: Sump Cleaners feature high impact, fiber reinforced, hard plastic casters and wheels for low rolling resistance, whether the unit is empty or full. The standard wheel configuration places the main wheels in the unit's middle and swivel casters on each end for high maneuverability. A Sump Cleaner pivots within its own length while "tricycle gear" units swing in double their length.

Clamped basket lids make lid removal and replacement much faster and easier than it is with the screw clamps used on other makes of sump cleaners. Easy Lift Chip Basket Lid allows the lid to easily and safely lift up and out of the way to allow access to the chip basket.

External, leak-proof, round cleanout doors are faster and easier to remove and replace than the oval, internal "manholes" used by other manufacturers. The thick, pliable gasket bonded to the cleanout door virtually eliminates leaks.

Forklift truck brackets are standard on all "push-around" Sump Cleaners so that the unit can be safely and easily picked up and moved long distances.



(Standard design units are not intended to be towed. Special wheel designs are available at extra cost for units which the customer desires to tow.)

Smooth radius basket suction inlet virtually eliminates suction hose "chip jams".

Float switch overflow protection virtually eliminates pump damage and coolant spills by automatically shutting down the sump cleaner's motor when the tank is full.

Sump Cleaner Warranty

Eriez equipment warranty is defined in Eriez standard Terms and Conditions of Sale provided at the time of invoice and also available on www.eriez.com or by contacting Eriez. Equipment warranty includes all sump cleaners and is subject to the following exceptions and clarifications:

1. Gasoline and LP Gas internal combustion engines are not covered by this warranty, but rather are covered by the standard warranty of the engine manufacturer, which varies from model to model. Copies of the specific warranty of the manufacturer will be shipped with the unit and such warranties and limitations are incorporated by reference herein. Upon request, copies of the engine manufacturer's warranty will be provided in advance of shipment.
2. For units mounted on mobile platforms or other similar sub-assemblies, such as trucks, carts, or self-propelled platforms, Eriez makes no warranties for such sub-assemblies manufactured by third parties and specifically disclaims any warranties with regard thereto, including implied warranties of merchantability or fitness for a particular use. The only warranties as to such sub-assemblies are those extended to purchaser directly by the third-party manufacturer, and such warranties are subject to all of the terms, conditions, and limitations of the third party's warranties and are enforceable only against said third-party manufacturer. Eriez is not underwriting or guaranteeing their warranties, nor is Eriez an agent of said third-party manufacturers for purpose of pursuing warranty claims or making service arrangements or any other purpose. Copies of such third-party sub-assembly manufacturers' specific warranty information will be shipped with the unit, and such warranties and limitations are incorporated by reference herein. Upon request, copies of sub-assembly manufacturers' warranty information will be provided in advance of ordering or shipment.

3. On all units, including Sump Cleaners and other sump cleaning equipment, all wheels, casters and batteries are considered expendable or ordinary maintenance items and are expressly exempted from this warranty and are not covered by any other warranty, express or implied.

THE WARRANTIES DESCRIBED IN THE ABOVE PARAGRAPHS SHALL BE IN LIEU OF ANY OTHER WARRANTIES, EXPRESSED OR IMPLIED, INCLUDING BUT NOT LIMITED TO ANY IMPLIED WARRANTY OF MERCHANTABILITY OR FITNESS FOR A PARTICULAR PURPOSE. ERIEZ SHALL NOT, IN ANY EVENT, BE LIABLE FOR INCIDENTAL OR CONSEQUENTIAL DAMAGES; AND TOTAL LIABILITY OF ERIEZ SHALL NOT EXCEED THE COST OF REPAIRING OR REPLACING THE COVERED GOODS OR EQUIPMENT NOT WITHSTANDING ANY PROVISION OR PURCHASER'S PURCHASE ORDERS OR OTHER CONTRACT DOCUMENTS, ACCEPTANCE AND USE OF ERIEZ PRODUCTS BY PURCHASER CONSTITUTES ACCEPTANCE OF THESE LIMITATIONS OF ERIEZ LIABILITY AND WARRANTIES.

This warranty neither assumes nor authorizes any other person to assume for Eriez any other liability in connection with the equipment manufactured by Eriez. This warranty applies only within the boundaries of the United States of America, its territories and possessions, and Canada. This warranty is not assignable.

Original purchaser as used herein, shall mean only such person, persons, association or corporation which purchase the equipment hereinafter described for actual use.

This warranty does not apply to damage of any unit occurring in transit, caused by alteration by unauthorized persons, fire, accident, artificially generated electric current, acts of God, misuse or abuse, or any other cause whatsoever other than defects in factory workmanship and/or material.

Eriez shall not be liable for any damage to or loss of any cutting fluids or for loss of any income or profits due to the malfunctioning of the equipment hereinafter described, whether the malfunctioning is caused by defects in factory workmanship and/or faulty material, or any other cause whatsoever.

Component parts returned for replacement must show the original unit serial number from which they were removed. Parts returned without the aforementioned serial number will be replaced at established replacement prices. This warranty does not cover equipment damaged by misuse, negligence or accident. Vacuum and pressure relief valves are preset at the factory. ALTERATION OF THE SETTING EXCEPT WITH THE SPECIFIC AUTHORIZATION OF ERIEZ OR ITS AUTHORIZED REPRESENTATIVES WILL VOID THIS WARRANTY.

Assembly

1. Remove the cover of the basket. Keep hands and fingers from under the filter basket gasket. Take out the following items:
 - A. Filter basket (factory assembled with sleeve)
 - B. Discharge hose with nozzle
 - C. Suction hose
 - D. Cleaning tool
 - E. Spare filter sleeve or filter bags
 - F. LP bottle brackets (on LP models)
2. Check the locking pin that holds the filter basket's trapdoor shut. Make sure it is securely in place (fully extended as shown in the drawing at the end of the manual).
3. Keeping hands and fingers from under the basket lip, reseal the filter basket in the tank. Replace the tank lid and clamp it down.
4. Attach the suction hose to the intake connection on the tank lid. Attach the cleaning tool to this hose, then coil the hose around the push handle or hose hangers provided at the basket end of the tank. Place cleaning tool in pipe holder attached to the side of the tank.
5. Couple the discharge hose to the discharge connection on the side of the tank and coil it over the push handle or hose hangers provided. Make sure the discharge nozzle assembly is installed on the other end of the hose.
6. On LP models, remove the bolts from the side of the base plate and mount the bottle brackets on the plate using the bolts provided.



Operating Tips

Sump Cleaners have been designed to make the job of proper machine tool coolant sump cleaning as easy as possible for the operator of the sump cleaner. They have the power necessary for true, high-performance sump cleaning. They will vacuum from the sump anything that will pass through its two inch diameter suction hose and it will vacuum up water soluble coolant at nearly 100 gallons per minute. At the same time, all Sump Cleaners are designed with operator safety and ease of operation and maintenance as foremost considerations.

Although the units are designed for operator safety, before using the sump cleaner for the first time (and periodically thereafter for a review), read the section of this Operator's Manual entitled "Safety Information"

Operating Efficiency Tips

Here are some tips to improve the operating efficiency of your sump cleaner:

- Follow the sump cleaner's maintenance schedule carefully. Preventive maintenance is much less expensive than major repairs.
- Clean your sump cleaner (or just the filter tank of a twin compartment unit) once a month or whenever sludge or fines have become noticeable in the bottom of the tank.
- Rinse the unit with plain water and drain it completely by removing the drain plug whenever changing from one brand or type of coolant to another. There can be compatibility problems with some products, so avoid contamination. (Remember to replace the plug.)
- It is better to have one sump cleaner for use with water soluble coolants and another for use with cutting oils. If you must use one unit for both, the sump cleaner must be thoroughly cleaned when switching products. If at all possible, purchase a filter basket and a set of hoses for each product. (The sump cleaner tank is not too hard to clean, but the hoses and filter basket are.) Organize your machine pumping schedule so that during one week you are pumping machines running water solubles and the next week you are pumping machines running cutting oils. This minimizes cleaning the sump cleaner.
- When vacuuming out machines using water-miscible products (coolants, cleaners) put the cleaning tool on the bottom of the sump, and remove fluid and chips together.

- When vacuuming out machines using cutting or grinding oil, remove the oil first and then vacuum up the chips and fines.
- In the event you experience a stoppage in the unit's suction hose, the suction hose's cleaning tool should be held and pointed into the machine sump (NOTE: DO NOT POINT IT AT PERSONNEL) and the Sump Cleaner started in the discharge mode.

Usually, the discharge pressure generated is sufficient to clear the stoppage by blowing the obstruction back into the machine sump. If the stoppage is not cleared in this manner, remove the hose from the fitting, and physically remove the obstruction.

- Your Sump Cleaner can be used as a portable filter for your grinders that have only settling tanks. Vacuum out the coolant and the swarf and return filtered coolant to the grinder tank. If the standard polypropylene filter sleeve does not provide adequate filtration, fit the basket with our disposable 20-micron paper filter bag.
- When vacuuming out the machine, put the cleaning tool on the bottom of the sump and remove coolant and chips together.
- If heavy, deep sludge is in the machine sump (cast iron applications), remove the majority of liquid. Take the cleaning tool and mix the remaining liquid with the sludge and then vacuum this mixture out.
- **Do NOT alter the unit's vacuum relief valve settings.** You will not improve your sump cleaner's performance and you will void its warranty.
- **Do NOT use your unit for solvents, volatile or low flash point fluids of any type.** It is designed for use with coolants, cutting oils, water soluble machine cleaning solutions and parts washing compounds only.
- When pumping out of floor pits you can increase the efficiency by drilling a 1/4" hole in the cleaning tool below where the hose is attached. By keeping this hole above the fluid level, you allow more air to enter the hose which helps move the fluid up the hose faster and possibly allow pumping out of deeper pits.

If you have any questions about your unit or its suitability for a particular job, please contact Eriez at 814-835-6000.

LP Gas Models Operation

1. Before operating this equipment for the first time, and periodically thereafter, review the SAFETY INFORMATION.
2. The standard sump cleaner LP gas engine is equipped with LIQUID WITHDRAWAL regulators, for use with either LIQUID or VAPOR WITHDRAWAL LP GAS BOTTLES.
3. Suction and discharge cycles are controlled by a four-way valve in the piping from the SUCTION/DISCHARGE pump to the tank. Placing the valve's control lever in the horizontal position selects the SUCTION mode (FIGURE 1). Moving the lever a quarter turn to the vertical position selects the DISCHARGE mode (FIGURE 2).



FIGURE 1

Suction/Discharge lever - SUCTION position



FIGURE 2

Suction/Discharge lever - DISCHARGE position

4. Place the SUCTION/DISCHARGE lever in the horizontal (SUCTION) position. Open the LP Gas bottle valve. Open the suction inlet ball valve. Place choke in "ON" position (FIGURE 3). Turn ignition key to the "START" position (FIGURE 4) while moving choke to the "OFF" position. Release key when the engine starts and move choke to the "OFF" position.



FIGURE 3

Pull out for CHOKE



FIGURE 4

Turn key to START

5. Vacuum coolant and chips from the sump.
6. As soon as fluid stops passing through the hose, stop the engine by turning the IGNITION switch OFF. Close the gas bottle valve. This valve must always be closed when engine is not running. The tank's maximum capacity is, at most, 10% above the rated capacity. A float switch in the tank and wired into the engine ignition circuit will shut down the engine if overfilling starts to occur. If this happens, place the IGNITION switch in the OFF position, and close the gas bottle valve. Follow instructions for the discharge operation in Item 7.
7. **To return filtered chip-free coolant to the sump, or wash down the machine, or discharge dirty coolant into your recycling or disposal system**, close the suction inlet ball valve. Move the four-way valve control lever to the vertical (DISCHARGE) position. Open the gas bottle valve and place choke in "ON" position. Turn ignition key to the "START" position while moving choke to the "OFF" position. Release key when the engine starts and move choke to the "OFF" position. Depress the discharge hose nozzle valve.

- A. THE SUCTION/DISCHARGE lever must be turned its full quarter turn to the vertical (DISCHARGE) position in order to close a limit switch beneath the lever (FIGURE 5). This limit switch bypasses the float switch needed to prevent overfilling during the suction operation, but is not required for discharge operation. The engine won't start in the discharge mode if sump cleaner tank is full and the limit switch is not closed.



FIGURE 5

Limit switch under the suction/discharge lever

- B. Be sure the suction inlet ball valve is fully closed before operating in the discharge mode.
 - C. **IMPORTANT!** Be sure the suction inlet ball valve is fully closed or fully open, depending on the desired operation (closed-discharge, open-suction). Failure to do so will allow particulate to enter the valve seat and seize the valve.
8. When fluid stops passing through the hose, release pressure by shifting the SUCTION/DISCHARGE lever to the horizontal (SUCTION) position. This must be done before opening the inlet ball valve or removing tank lid, cleanout door or drain plug. The engine will momentarily "SPEED UP" and then "SLOW DOWN" and begin to "labor". Once the engine has begun to labor, the engine may be switched OFF. Open the ball valve and turn OFF the gas bottle valve.
 9. The cleaner will discharge all but about an inch of fluid in the bottom of the compartment. This is unimportant if the compartment is used for one type of coolant only. If different coolants are involved, remove the compartment's drain plug to empty it completely. Replace drain plug after emptying.

10. To empty the filter basket:

- A. Remove tower lid.
- B. Attach lifting device to basket rings. **CAUTION:** All components used to lift basket (steel cable, hooks, crane, etc.) must have a minimum capacity of 1000 pounds.
- C. To avoid the basket binding in the tower during removal, position the lifting power source (e.g. crane) directly over the center of the basket.
- D. Hoist the basket. Keep hands and fingers clear. If the basket is binding and unable to lift freely, return (lower) the basket to the sump cleaner tower. Reposition the lifting device so that the basket exits the center of the tower.
- E. **DO NOT TOUCH BASKET DURING REMOVAL.**
- F. Position the basket over the waste receptacle.
- G. Standing clear, open the basket trapdoor by pulling the locking pin cable.
- H. Once the basket is empty, carefully close the trapdoor and slide the locking pin into place.
- I. Check the filter sleeve. If it is badly soiled or clogged, turn it inside out and wash it in a suitable cleaner. Replace filter when necessary. (Refer to the MAINTENANCE section of this manual.)
- J. Inspect the basket hoisting rings for signs of rust. Replace the basket with a new one if the rings are heavily corroded.
- K. Keeping hands and fingers from under the basket lip, reseat the basket in the tank and clamp down the tank lid.

LP Gas Dual Tank Models Operation

1. Before operating this equipment for the first time, and periodically thereafter, review the SAFETY INFORMATION.
2. The standard sump cleaner LP gas engine is equipped with LIQUID WITHDRAWAL regulators for use with either LIQUID or VAPOR WITHDRAWAL LP GAS BOTTLES.
3. Suction and discharge cycles are controlled by a four-way valve in the piping from the SUCTION/DISCHARGE pump to the tank. Placing the valve's control lever in the horizontal position selects the SUCTION mode (FIGURE II-A). Moving the lever a quarter turn to the vertical position selects the DISCHARGE mode (FIGURE II-B).



FIGURE II-A
Suction/Discharge lever - SUCTION position



FIGURE II-B
Suction/Discharge lever - DISCHARGE position

4. Suction vacuum or discharge pressure is applied to both tank compartments simultaneously. No valves are used to select one tank compartment from the other. Select the compartment to be used by attaching the suction and discharge hoses to the proper fittings on that tank compartment. Cap off all other fittings.
5. **For dirty fluid suction operation:** Activate the float switch for the compartment selected by setting the TANK OVERFILL PROTECTION SELECTOR SWITCH to the appropriate position. This float switch prevents over-filling of the compartment and pump damage during the suction cycle by turning off the engine's ignition circuit at a predetermined liquid level. Make sure all 1-1/2" female quick disconnect caps are installed on the male fittings on the clean side and the dirty side discharge ports.
 - A. Place the SUCTION/DISCHARGE lever in the horizontal (SUCTION) position. Open the LP Gas bottle valve. Open the suction inlet ball valve. Place choke in "ON" position. Turn ignition key to the "START" position while moving choke to the "OFF" position. Release key when the engine starts and move choke to the "OFF" position.



Pull out for CHOKE



Turn key to START

- B. Vacuum coolant and chips from the sump.
- C. As soon as fluid stops passing through the hose, stop the engine by turning the IGNITION switch OFF. Close the gas bottle valve. This valve must always be closed when engine is not running.

The tank's maximum capacity is, at most, 10% above the rated capacity. A float switch in the tank and wired into the engine ignition circuit will shut down the engine if overfilling starts to occur. If this happens, place the IGNITION switch in the OFF position, and close the gas bottle valve. Follow instructions for the discharge operation in Paragraph 10.

6. To return filtered chip-free coolant to the sump, or wash down the machine, or discharge dirty coolant into your recycling or disposal system, close the suction inlet ball valve V1, attach the 1-1/2" hose to the discharge port. Move the 4-way valve control lever to the vertical (DISCHARGE) position. Open the gas bottle valve and press the electric primer button for at least two seconds. Turn the IGNITION KEY SWITCH ON. Depress the discharge hose nozzle valve.

A. THE SUCTION/DISCHARGE lever must be turned its full quarter turn to the vertical (DISCHARGE) position in order to close a limit switch beneath the lever (FIGURE 5). This limit switch bypasses the float switch needed to prevent overfilling during the suction operation, but is not required for discharge operation. The engine won't start in the discharge mode if sump cleaner tank is full and the limit switch is not closed.



FIGURE II-C

Limit switch under the suction/discharge lever

B. Be sure the suction inlet ball valve V1 is fully closed before operating in the discharge mode.

C. **IMPORTANT!** Be sure the suction inlet ball valve V1 is fully closed or fully open, depending on the desired operation (closed-discharge, open-suction). Failure to do so will allow particulate to enter the valve seat and seize the valve.

D. As soon as fluid stops passing through the hose, release pressure by shifting the SUCTION/DISCHARGE lever to the horizontal (SUCTION) position. This must be done before opening the inlet ball valve or removing tank lid, cleanout door or drain plug. The engine will momentarily "SPEED UP" and then "SLOW DOWN" and begin to "labor". Once the engine has begun to labor, the engine may be switched OFF. Open the ball valve and turn OFF the gas bottle valve.

The sump cleaner will discharge all but about an inch of fluid in the bottom of the compartment. This is unimportant if the compartment is used for one type of coolant only. If different coolants are involved, remove the compartment's drain plug to empty it completely. Replace drain plug after emptying.

7. To fill the clean side with clean fluid: Activate the float switch for the compartment selected by setting the TANK OVERFILL PROTECTION SELECTOR SWITCH to the appropriate position (FIGURE II-C). This float switch prevents over-filling of the compartment and pump damage during the suction cycle by turning off the engine's ignition circuit at a predetermined liquid level.

A. Install the 1-1/2" hose onto the clean side inlet port, remove the discharge nozzle and install that end of the hose to a recycling system or a clean tank

B. Place the SUCTION/DISCHARGE lever in the horizontal (SUCTION) position. Open the LP Gas bottle valve. Open the suction inlet ball valve. Place choke in "ON" position. Turn ignition key to the "START" position while moving choke to the "OFF" position. Release key when the engine starts and move choke to the "OFF" position.

- C. Vacuum new fluid into the sump cleaner.
- D. As soon as fluid stops passing through the hose, stop the engine by turning the IGNITION switch OFF. Close the gas bottle valve. This valve must always be closed when engine is not running

The tank's maximum capacity is, at most, 10% above the rated capacity. A float switch in the tank and wired into the engine ignition circuit will shut down the engine if overfilling starts to occur. If this happens, place the IGNITION switch in the OFF position, and close the gas bottle valve. Follow instructions for the discharge operation in Paragraph 10.

- 8. To discharge clean fluid:** close the suction inlet ball valve V1, attach the 1-1/2" hose to the discharge port on the clean side of the unit. Move the 4-way valve control lever to the vertical (DISCHARGE) position. Open the gas bottle valve and press the electric primer button for at least two seconds. Turn the IGNITION KEY SWITCH ON. Depress the discharge hose nozzle valve.
- A. THE SUCTION/DISCHARGE lever must be turned its full quarter turn to the vertical (DISCHARGE) position in order to close a limit switch beneath the lever (FIGURE II-F). This limit switch bypasses the float switch needed to prevent overfilling during the suction operation, but is not required for discharge operation. The engine won't start in the discharge mode if sump cleaner tank is full and the limit switch is not closed.
 - B. Be sure the suction inlet ball valve V1 is fully closed before operating in the discharge mode!
 - C. IMPORTANT! Be sure the suction inlet ball valve V1 is fully closed or fully open, depending on the desired operation (closed-discharge, open-suction). Failure to do so will allow particulates to enter the valve seat and seize the valve.

- D As soon as fluid stops passing through the hose, release pressure by shifting the SUCTION/ DISCHARGE lever to the horizontal (SUCTION) position. This must be done before opening the inlet ball valve or removing tank lid, cleanout door or drain plug. The engine will momentarily "SPEED UP" and then "SLOW DOWN" and begin to "labor". Once the engine has begun to labor, the engine may be switched OFF. Open the ball valve and turn OFF the gas bottle valve.

The sump cleaner will discharge all but about an inch of fluid in the bottom of the compartment. This is unimportant if the compartment is used for one type of coolant only. If different coolants are involved, remove the compartment's drain plug to empty it completely. Replace drain plug after emptying.



LP Gas Maintenance Schedule

Daily	Weekly	Monthly	100 Hours	200 Hours	500 Hours	6 Months	12 Months	Maintenance Schedule for LP Gas/Gasoline Sump Cleaners	Maintenance Log							
									Date Placed into Service:							
									Record Date of Service Below:							
								Check engine oil level; add SAE 10W-30 oil as needed								
								Change engine oil - 1st change at 4 hours; oil filter at 200 hours #12-05001								
								Inspect suction & discharge hoses; replace as needed								
								Inspect tank for sludge buildup; clean as needed								
								Check blower oil level; add SAE-40 non-detergent oil as needed								
								Grease blower; use #2 bearing grease (500 hours)								
								Check engine air filter; replace as needed; check LP fuel filter; repair or replace as needed. Clean and re-oil pre-cleaner								
								Grease wheels & casters; use #2 bearing grease								
								Check engine spark plug; replace with champion #RC20YC; gapped to 0.30								
								Change blower oil; use SAE-40 non-detergent oil (1500 hours)								
								Check fuel filter								
								Drain LP regulator								
								Drain blower mufflers (drain plug is on lower end of muffler) if equipped with optional sound reduction mufflers								

Spare Parts List

Sump Cleaner LP Push/Pull

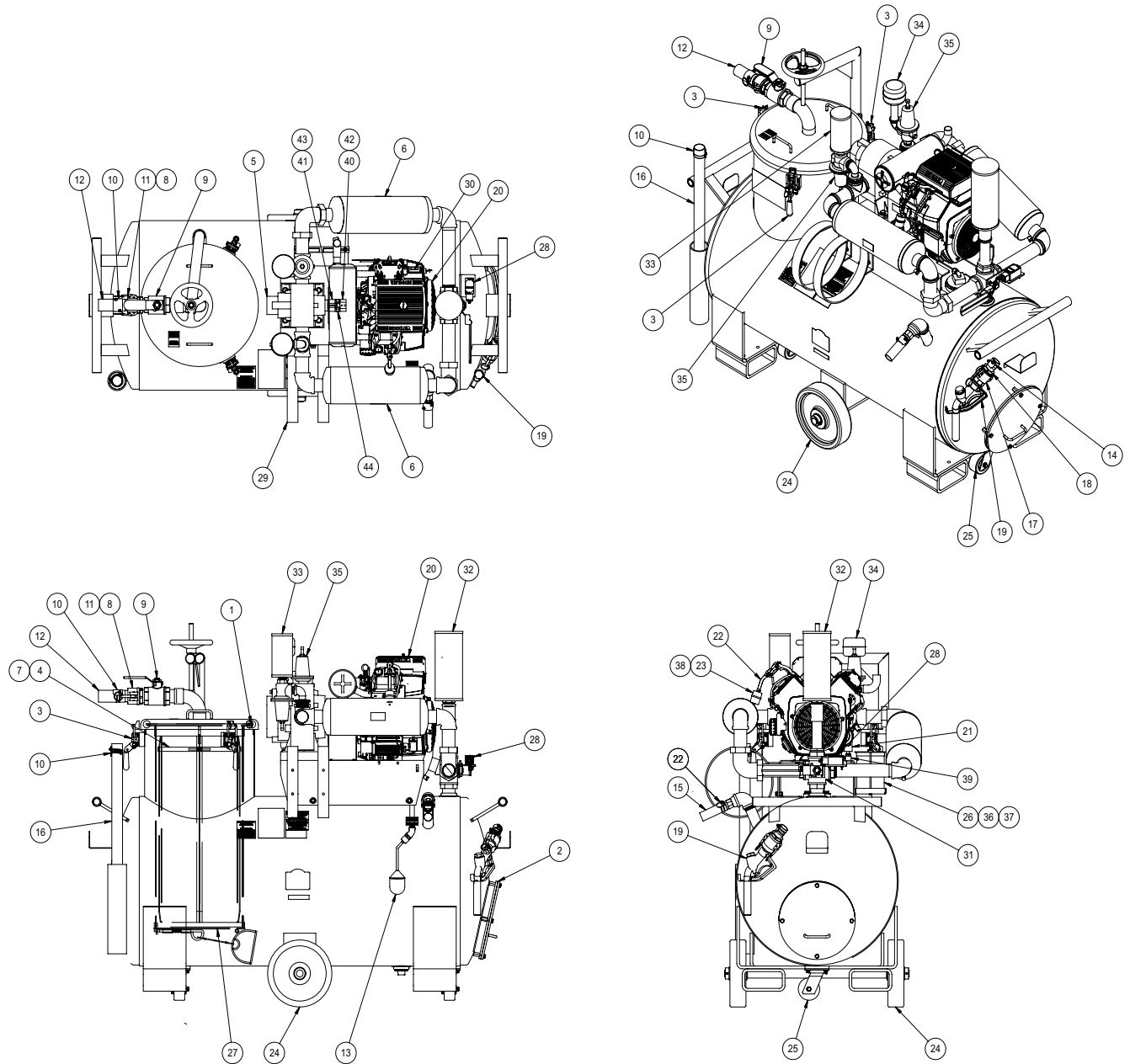

Part #	Stock #	Description
1	60-1560	LID GASKET
2	60-1520	CLEANOUT GASKET
3	40-1140	CLAMP
4	60-1140	BASKET RETAINING RING
5	54-1040	BLOWER 3MVR VERTICAL
6	2N-201211020	MUFFLER ASSEMBLY
7	60-1460	FILTER SLEEVE POLY
8	42-0132	QUICK CONNECT 2 MAL X 2 MNPT
9	25-1400	VALVE 2 NPT BRASS BALL FULL
10	41-1010	CLAMP 2" SPIRAL DOUBLE
11	42-0133	QUICK CONNECT 2 FEMALE X BARS
12	41-2110	HOSE ORANGE SUCTION 2" ID
13	38-1120	FLOAT SWITCH
14	41-0980	CLAMP 1-1/2" SPIRAL DOUBLE
15	41-2090	ORANGE DISCHARGE HOSE
16	60-1220	TOOL CLEANING ALUM. 2" X 36" LG
17	42-1200	CONNECTOR QD 1-1/2 FEMALE X 1
18	42-1150	QD 1-1/2 MALE X BARB ALUM.
19	60-1960	NOZZLE 1" NPT
20	50-1060	ENGINE 25HP
21	29-1160	GAUGE VACUUM-PRESSURE
22	41-0980	CLAMP TIGER 1-1/2" SPIRAL DBLE
23	23-1180	CONNECTOR FEMALE LP GAS 1-1/4
24	43-1240	WHEEL 12" X 3" X 1-1/4" PHENOLIC
25	43-1060	CASTER SWIVEL PHENOLIC 4" X 2"
26	30-1000	BATTERY 12V
27	60-1080	BASKET ASSEMBLY SLUDGE 36"
28	30-1960	LIMIT SWITCH
29	60-1180	BRACKET LP TANK SET
30	30-1725	TACH TINY
31	25-1500	VALVE 2" NPT 4-WAY
32	60-1720	MUFFLER EXHAUST W/ 1-1/2" MNPT
33	60-1700	MUFFLER EXHAUST W/ 1" MNPT
34	457955	MUFFLER ENGINE 1" FNPT
35	24-1020	VALVE PRESSURE RELIEF 1" NPT
36	05-1120	RUBBER BASE
37	05-1135	RUBBER COVER
38	51-1485	SOLENOID 12VDC
39	51-2020	KIT OIL DRAIN VALVE
40	321200	BAR STEEL CR 1/4" SQ. (2" LG.)
41	407625	BAR KEYSTOCK 3/16" SQ. (2" LG.)
42	55-1294	DRIVE COUPLING
43	55-1292	DRIVE COUPLING
44	55-1290	INSERT SLEEVE

Spare Parts List

Sump Cleaner LP Tow

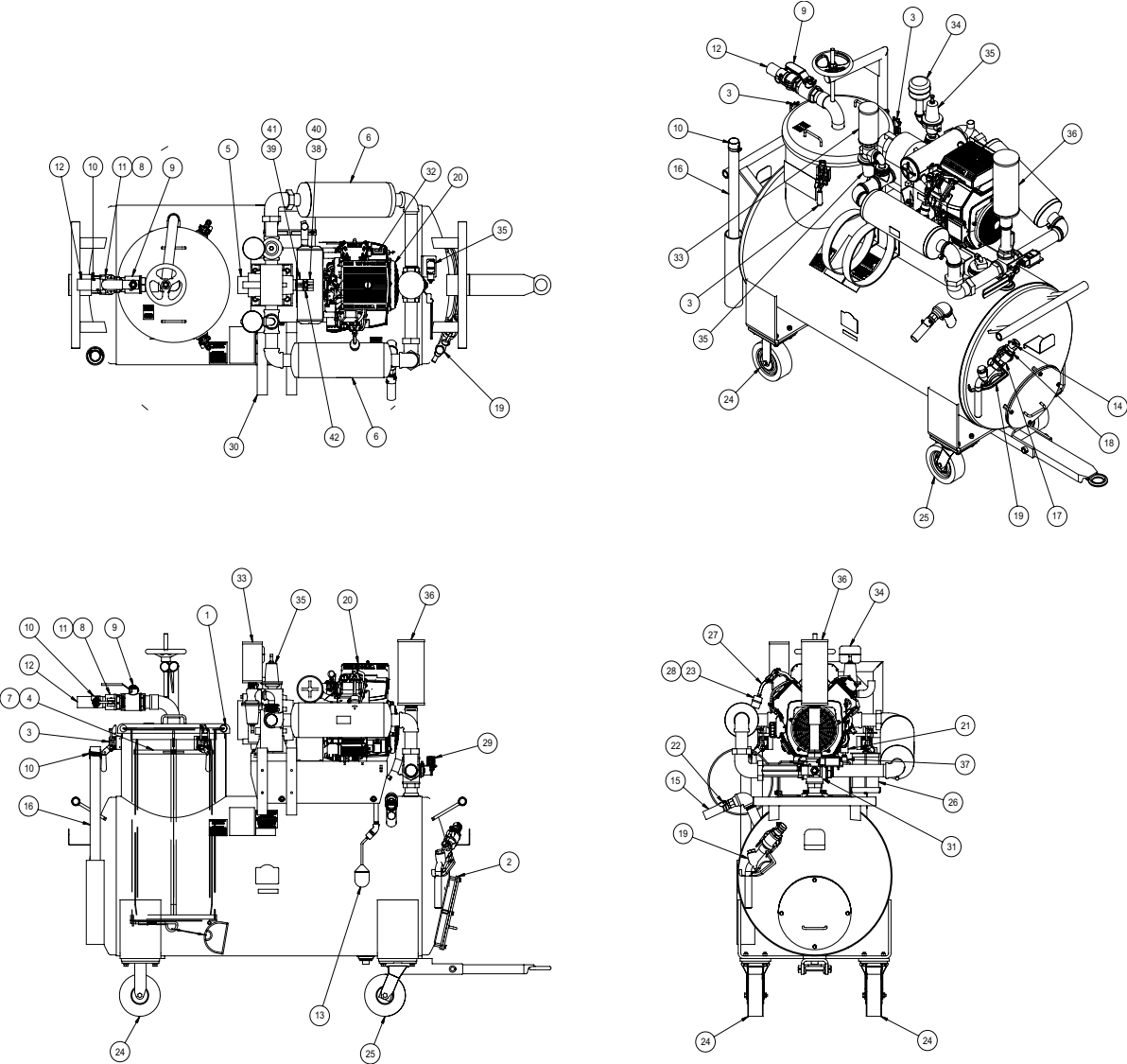

Part #	Stock #	Description
1	60-1560	LID GASKET
2	60-1520	CLEANOUT GASKET
3	40-1140	CLAMP
4	60-1140	BASKET RETAINING RING
5	54-1040	BLOWER 3MVR VERTICAL
6	2N-201211020	MUFFLER ASSEMBLY
7	60-1460	FILTER SLEEVE POLY
8	42-0132	QUICK CONNECT 2 MAL X 2 MNPT
9	25-1400	VALVE 2 NPT BRASS BALL FULL
10	41-1010	CLAMP 2" SPIRAL DOUBLE
11	42-0133	QUICK CONNECT 2 FEMALE X BARS
12	41-2110	HOSE ORANGE SUCTION 2" ID
13	38-1120	FLOAT SWITCH
14	41-0980	CLAMP 1-1/2" SPIRAL DOUBLE
15	41-2090	ORANGE DISCHARGE HOSE
16	60-1220	TOOL CLEANING ALUM. 2" X 36" LG
17	42-1200	CONNECTOR QD 1-1/2 FEMALE X 1
18	42-1150	QD 1-1/2 MALE X BARB ALUM.
19	60-1960	NOZZLE 1" NPT
20	50-1060	ENGINE 25HP
21	29-1160	GAUGE VACUUM-PRESSURE
22	41-0980	CLAMP TIGER 1-1/2" SPIRAL DBLE
23	23-1180	CONNECTOR FEMALE LP GAS 1-1/4
24	43-1140	CASTER RIDGID 8 X 3
25	43-1160	CASTER SWIVEL 8 X 3
26	30-1000	BATTERY 12V
27	41-2280	HOSE PETROLEUM GAS 5/16" ID
28	51-1485	SOLENOID 12VDC
29	30-1960	LIMIT SWITCH
30	60-1180	BRACKET LP TANK SET
31	25-1500	VALVE 2" NPT 4-WAY
32	30-1725	TACH TINY
33	60-1700	MUFFLER EXHAUST W/ 1" MNPT
34	457955	MUFFLER ENGINE 1" FNPT
35	24-1020	VALVE PRESSURE RELIEF 1" NPT
36	60-1720	MUFFLER EXHAUST W/ 1-1/2" MNPT
37	51-2020	KIT OIL DRAIN VALVE
38	321200	BAR STEEL CR 1/4" SQ. (2" LG.)
39	407625	BAR KEYSTOCK 3/16" SQ. (2" LG.)
40	55-1294	DRIVE COUPLING
41	55-1292	DRIVE COUPLING
42	55-1290	INSERT SLEEVE

Air-Operated Models Operation

Before operating this equipment for the first time, and periodically thereafter, review the SAFETY INFORMATION.

Standard Safety Features

Your Sump Cleaner comes equipped with redundant safety features to assure that it operates in the safe optimal pressure range. The standard regulator is factory set at 7 PSI. This assures that air entering your unit to create the pressure needed for discharge does not exceed safe levels.



In the event of a failure of the regulator, as a backup, the Sump Cleaner also features a standard “safety release valve” which is designed to release pressure in excess of 8 PSI.



As part of your regular maintenance program, you should examine both the regulator and safety release valve to make sure that neither has been damaged during use and that both are free from dirt or materials which might plug openings or interfere with their operation. The regulator should be periodically checked to make sure that it is set and operating at 7 PSI. If either component becomes damaged or is not operating as intended, the unit should be taken out of service immediately until the parts are repaired or replaced.

DO NOT eliminate the safety release valve or replace it with a release valve rated higher than 15 PSI.

DO NOT reset the regulator to a pressure setting above 7 PSI.

If you need information about the use or pressurization of your Sump Cleaner or replacement parts for your unit, contact Eriez at 814-835-6000.

Operation Requirements: 60-90 PSI 32-47 CFM 1/2" ID Air Line Required

1. Before operating this equipment for the first time, and periodically thereafter, review the SAFETY INFORMATION included in this manual.
2. Suction Operation:
 - A. Connect the shop's compressed air supply line to the sump cleaner's vacuum generator inlet.
 - B. Open suction inlet valve and vacuum valve.
 - C. Turn on the compressed air to the sump cleaner. Vacuum coolant, chips and sludge from the machine sump.
 - D. When you are done vacuuming coolant, turn off the compressed air to the sump cleaner.
 - E. The tank's maximum capacity is, at most, 10% above the rated capacity. A mechanical float located in the tank near the vacuum valve will rise with the rising liquid level in the tank and shut off the vacuum when the tank is full. When this occurs, the sump cleaner will stop vacuuming. Turn off the compressed air to the sump cleaner and prepare to discharge the coolant.



3. Discharge Operation: To return filtered, chip-free coolant to the machine, to wash down the machine, or to discharge coolant into your recycling or disposal system:

- A. Close the suction inlet valve completely.
- B. Close the vacuum valve completely.
- C. Connect the compressed air supply line to the compressed air inlet. (This compressed air inlet is equipped with a preset, nonadjustable pressure reducing regulator to lower the air pressure to 7 PSI. A 15 PSI safety “POP-OFF” valve in this same line acts as a back up to prevent over-pressurizing the sump cleaner tank). Turn on the air supply by opening discharge valve.
- D. Depress the discharge hose nozzle handle.
- E. When discharging operation is complete, turn off the compressed air supply by closing discharge valve and close the discharge nozzle.
- F. Discharge valve is a three-way ball valve that will depressurize the sump cleaner tank when fully closed. To avoid possible injury, do not leave the sump cleaner pressurized.

4. To empty the filter basket:

- A. Remove tower lid.
- B. Attach lifting device to basket rings.
CAUTION: All components used to lift basket (steel cable, hooks, crane, etc.) must have a minimum capacity of 1000 pounds.

- C. To avoid the basket binding in the tower during removal, position the lifting power source (e.g. crane) directly over the center of the basket.
- D. Hoist the basket. Keep hands and fingers clear. If the basket is binding and unable to lift freely, return (lower) the basket to the sump cleaner tower. Reposition the lifting device so that the basket exits the center of the tower.
- E. **DO NOT TOUCH BASKET DURING REMOVAL.**
- F. Position the basket over the waste receptacle.
- G. Standing clear, open the basket trapdoor by pulling the locking pin cable.
- H. Once the basket is empty, carefully close the trapdoor and slide the locking pin into place.
- I. Check the filter sleeve. If it is badly soiled or clogged, turn it inside out and wash it in a suitable cleaner. Replace filter when necessary. (Refer to the MAINTENANCE section of this manual.)
- J. Inspect the basket hoisting rings for signs of rust. Replace the basket with a new one if the rings are heavily corroded.
- K. Keeping hands and fingers from under the basket lip, reseal the basket in the tank and clamp down the tank lid.

Weekly	Monthly	6 Months	100 Hours	12 Months	Maintenance Schedule for Air Venturi Sump Cleaners	Maintenance Log							
						Date Placed into Service:							
						Record Date of Service Below:							
					Inspect suction and discharge hoses; replace as needed								
					Inspect filter basket sleeve; replace as needed. Inspect basket lifting rings for corrosion								
					Inspect tank for sludge buildup; clean as needed								
					Grease wheels and casters; use No. 2 bearing grease								

Air Venturi Dual Tank Operation

Before operating this equipment for the first time, and periodically thereafter, review the SAFETY INFORMATION.

Suction vacuum and discharge pressure are independently applied to each of the compartments of this dual compartment unit. Select the compartment to be used by opening or closing the appropriate vacuum and discharge valves and by attaching the hoses to the appropriate fittings and cap off the other tank fittings.

1. For suction operation to remove dirty coolant and chips from a machine sump:

- A. Connect the shop's compressed air supply line to the sump cleaner's vacuum generator inlet (CA1).
- B. Open suction inlet valve (S1) and vacuum valve (V1). All other valves should be closed for this operation.
- C. Turn on the compressed air to the sump cleaner. Vacuum coolant, chips and sludge from the machine sump.
- D. Turn off the compressed air when finished cleaning the machine.
- E. The tank's maximum capacity is, at most, 10% above the rated capacity. Mechanical floats located in the tank near the vacuum valve will rise with the rising liquid level in the tank and shut off the vacuum when the tank is full. When this occurs, the sump cleaner will stop sucking; turn off the compressed air to the sump cleaner and prepare to discharge the coolant.

2. For suction operation to fill clean coolant compartment:

- A. Connect compressed air line to air inlet (CA1).
- B. Close suction inlet valve (S1) and vacuum valve (V1). Open vacuum valve (V2).
- C. Attach the 1-1/2" hose to the clean coolant compartment inlet/discharge port and remove the discharge nozzle.

- D. Attach the nozzle end of this hose to the clean coolant supply tank. Turn on the compressed air and reattach the discharge nozzle to the hose when full. Close vacuum valve (V2). The compressed air inlet is equipped with a preset, nonadjustable pressure-reducing regulator to lower the air pressure to 7 psi. A 15 psi safety (POP-OFF) valve in this same line acts as a back up to prevent over-pressurizing the sump cleaner tank.

3. Discharge Operation to fill a machine tool with clean coolant:

- A. Close valves S1, V1, V2 and D1.
- B. Place the discharge nozzle into the machine sump and turn on the compressed air by opening discharge valve D2. Open the discharge nozzle and fill the coolant sump. Close the nozzle and turn off the compressed air by closing discharge valve D2.
- C. Connect the compressed air supply to the compressed air inlet (CA2).

4. Discharge operation to return filtered, chip-free coolant to the machine to wash down the machine or to discharge coolant into your recycling or disposal system:

- A. Close valves S1, V1, V2 and D2 completely.
- B. Attach the 1-1/2" hose to the dirty coolant discharge port.
- C. Connect the compressed air supply line to the compressed air inlet (CA2).
- D. Open discharge valve (D1) to empty filtered chip-free coolant.
- E. When discharging operation is complete, turn off the compressed air supply by closing discharge valve D1. The sump cleaner will discharge all but about an inch of fluid in the bottom of the tank. This is unimportant if the cleaner is used for one type of coolant only. If different coolants are involved, remove the tank's drain plug to empty it completely.

NOTE: Discharge valves D1 and D2 are three-way ball valves that will depressurize the sump cleaner tank when fully closed. To avoid possible injury, do not leave the sump cleaner pressurized.



Spare Parts List

AirVenturi Push/Pull

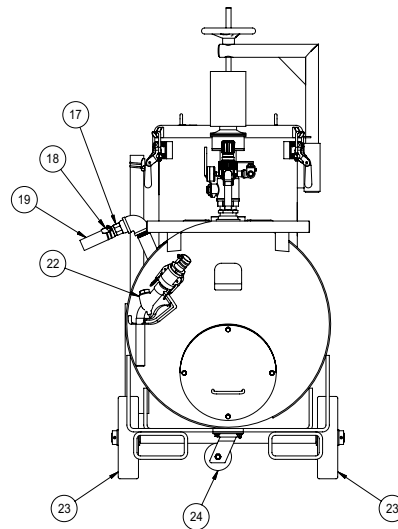
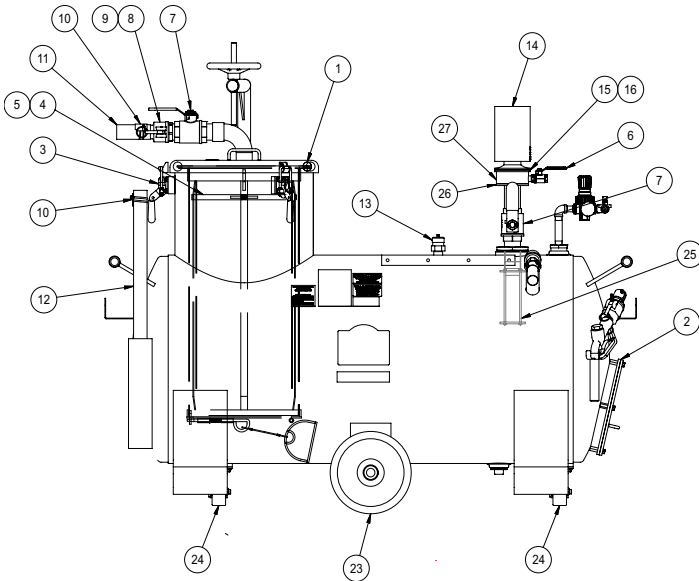
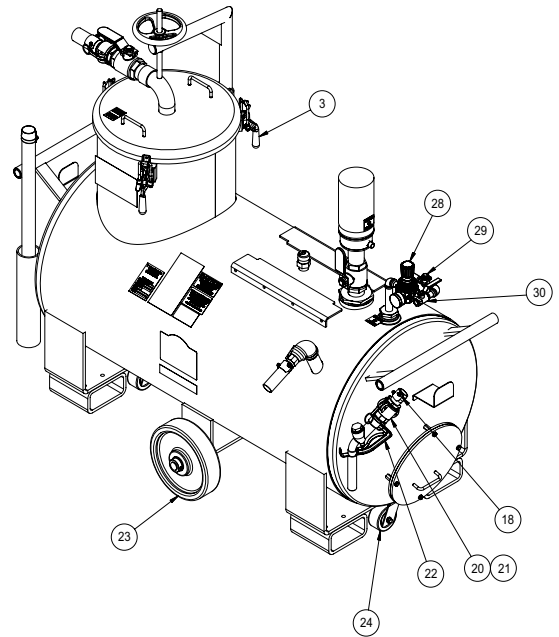
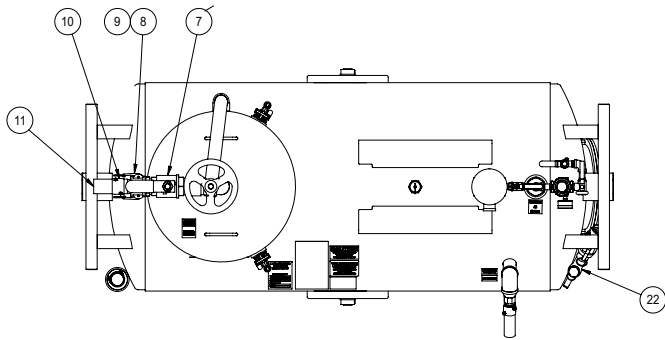

Parts List: Page 24

Part #	Stock #	Description
1	60-1560	LID GASKET
2	60-1520	CLEANOUT GASKET
3	40-1140	CLAMP
4	60-1140	BASKET RETAINING RING
5	60-1460	FILTER SLEEVE POLY
6	25-1100	VALVE 1/2 NPT BRASS BALL
7	25-1400	VALVE 2 NPT BRASS BALL FULL
8	42-0132	QUICK CONNECT 2 MAL X 2 MNPT
9	42-0133	QUICK CONNECT 2 FEM X BARB
10	41-1010	CLAMP 2" SPIRAL DOUBLE
11	41-2110	HOSE ORANGE SUCTION 2" ID
12	60-1220	TOOL CLEANING ALUM 2 X 36 L
13	24-1000	3/4" LOW PRESSURE RELIEF
14	54-1140	VENTURI POWERHEAD
15	54-1230	VENTURI GASKET
16	54-1160	VENTURI ADAPTER
17	42-1220	HOSE BARB 1-1/2" PLATED STEEL
18	41-0980	CLAMP 1-1/2" SPIRAL DOUBLE
19	41-2090	TUBING ORANGE DISCHARGE 1.5 ID
20	42-1200	CONNECTOR QD 1-1/2 FEMALE X 1
21	42-1150	CONNECTOR QD 1-1/2 MALE X BARB
22	60-1960	NOZZLE 1 NPT
23	43-1240	WHEEL 12 X 3 X 1-1/4 PHENOLIC
24	43-1060	CASTER SWIVEL PHENOLIC 4 X 2
25	2N-201102599	LIQUID SHUTOFF FLOAT WELDMENT
26	2N-201102769	VENTURI ADAPTER WASHER WELDMENT
27	54-1160	POWER VENTURI ADAPTER & GASKET
28	28-1040	REGULATOR 1/2" PORT
29	460356	VALVE SWING CHECK 1/2"
30	25-1120	VALVE BALL 1/2" NPT 3-WAY BRASS



Spare Parts List

AirVenturi Tow

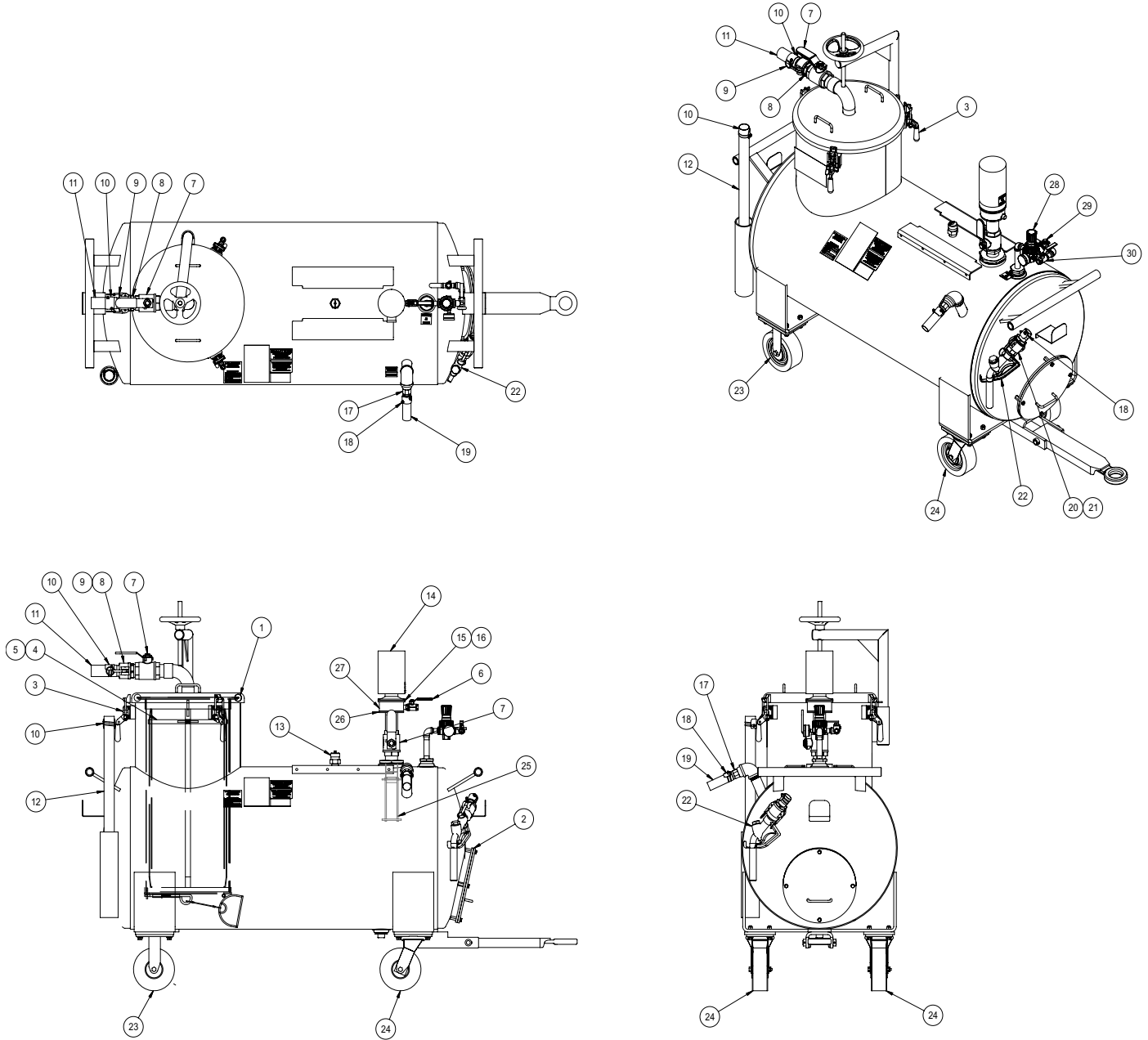

Parts List: Page 26

Part #	Stock #	Description
1	60-1560	LID GASKET
2	60-1520	CLEANOUT GASKET
3	40-1140	CLAMP
4	60-1140	BASKET RETAINING RING
5	60-1460	FILTER SLEEVE POLY
6	25-1100	VALVE 1/2 NPT BRASS BALL
7	25-1400	VALVE 2 NPT BRASS BALL FULL
8	42-0132	QUICK CONNECT 2 MAL X 2 MNPT
9	42-0133	QUICK CONNECT 2 FEM X BARB
10	41-1010	CLAMP 2" SPIRAL DOUBLE
11	41-2110	HOSE ORANGE SUCTION 2" ID
12	60-1220	TOOL CLEANING ALUM 2 X 36 L
13	24-1000	3/4" LOW PRESSURE RELIEF
14	54-1140	VENTURI POWERHEAD
15	54-1230	VENTURI GASKET
16	54-1160	VENTURI ADAPTER
17	42-1220	HOSE BARB 1-1/2" PLATED STEEL
18	41-0980	CLAMP 1-1/2" SPIRAL DOUBLE
19	41-2090	TUBING ORANGE DISCHARGE 1.5 ID
20	42-1200	CONNECTOR QD 1-1/2 FEMALE X 1
21	42-1150	CONNECTOR QD 1-1/2 MALE X BARB
22	60-1960	NOZZLE 1 NPT
23	43-1140	CASTER RIGID 8 X 3
24	43-1160	CASTER SWIVEL 8 X 3
25	2N-201102599	LIQUID SHUTOFF FLOAT WELDMENT
26	2N-201102769	VENTURI ADAPTER WASHER WELDMENT
27	54-1160	POWER VENTURI ADAPTER & GASKET
28	28-1040	REGULATOR 1/2" PORT
29	460356	VALVE SWING CHECK 1/2"
30	25-1120	VALVE BALL 1/2" NPT 3-WAY BRASS



Spare Parts List

50 Gallon Air Sump

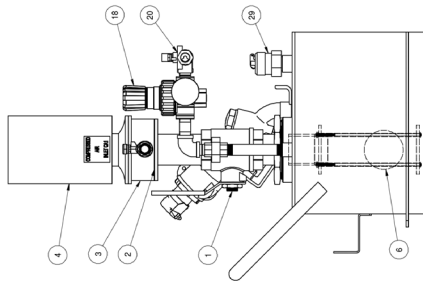
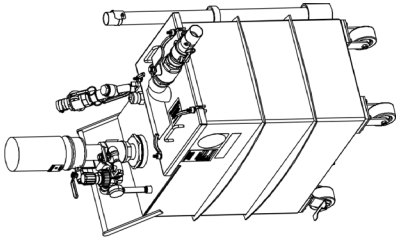

VIEW A-A
SCALE 1/4

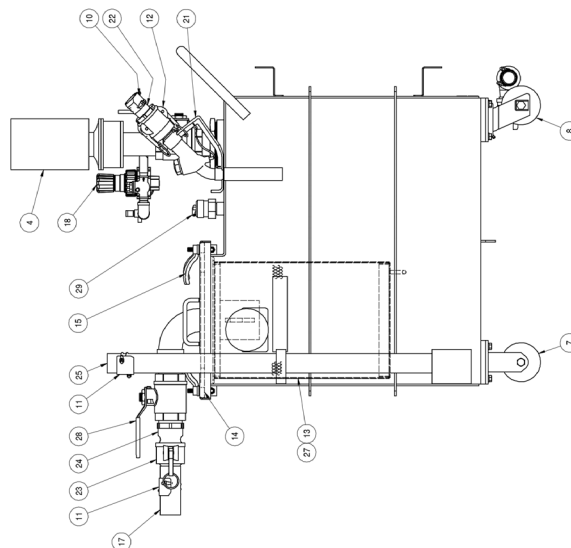
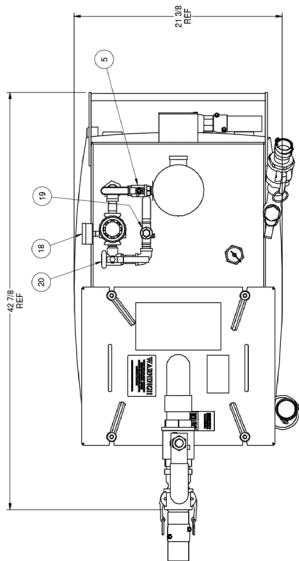
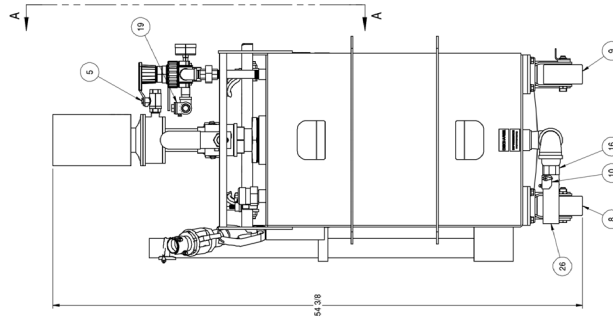

Parts List: Page 28

Part #	Stock #	Description
1	25-1400	VALVE 2 NPT BALL
2	54-1230	GASKET
3	54-1160	POWERHEAD VENTURI ADPT & GASKET
4	54-1140	POWERHEAD VENTURI
5	25-1100	VALVE 1/2 BALL
6	38-1141	FLOAT PLASTIC BALL 3"
7	43-1020	CASTER RIGID
8	43-1060	CASTER SWIVEL
9	43-1040	CASTER SWIVEL W/BREAK
10	41-0980	CLAMP 1-1/2" SPIRAL DOUBLE
11	41-1010	CLAMP 2" SPIRAL DOUBLE
12	42-1200	CONNECTOR QD 1-1/2 FEMALE X 1
13	60-1450	FILTER SLEEVE
14	463031	GASKET LID
15	40-1150	HANDLE
16	42-1220	HOSE BARB 1-1/2"
17	41-2110	HOSE ORANGE 2" ID
18	28-1040	REGULATOR
19	460356	VALVE SWING CHECK 1/2"
20	25-1120	VALVE BALL 1/2 NPT
21	60-1960	NOZZLE 1 NPT
22	42-1140	CONNECTOR QD 1-1/2 MALE X BARB
23	42-0133	QUICK CONNECT 2 FEMLAE X BARB
24	42-0132	QUICK CONNECT 2 MALE X 2 MNPT
25	60-1220	TOOL CLEANING ALUM 2 X 36 L
26	41-2090	TUBING ORANGE PVC 1.5 ID
27	31-3270	TY-RAP CABLE
28	25-1400	VALVE 2 NPT BALL
29	467517	VALVE 3/4" LOW PRESSURE POP SAFETY REL



120V Electric Models Operation

1. Before operating this equipment for the first time, and periodically thereafter, review the SAFETY INFORMATION.
2. Suction vacuum and discharge pressure are applied independently in this unit by moving a hose attached to the tank to either the suction fitting or the discharge fitting to the powerhead enclosure as required.



3. Connect the Sump Cleaner to the electrical supply specified on the electrical box housing the motor. For North America, this is 120 VAC, single phase, 60 Hz.

4. Suction Operation:

- A. Connect the black hose to the suction port on the electrical box containing the motor assembly.



- B. Open suction inlet valve fully with suction hose properly attached. **MAKE SURE THAT THIS VALVE IS EITHER FULLY OPEN OR FULLY CLOSED AT ALL TIMES. FAILURE TO DO SO WILL ALLOW PARTICULATE MATTER TO ENTER THE VALVE SEAT, WHICH COULD SEIZE THE VALVE.**
- C. Make sure that the discharge hose is connected, and that the discharge nozzle is attached and closed.
- D. Turn on the Sump Cleaner by placing the “on-off-on” switch into the “SUCTION ON” position. **NOTE:** The float switch will only work when “suction on” is selected. It is not wired into the “discharge on” circuit.



- E. Vacuum coolant, chips, and sludge from the machine sump.
 - F. An electric float located in the tank will rise with the rising liquid level in the tank and shut off the motor when the tank is full. When this occurs, the Sump Cleaner will stop.
 - G. When you are done vacuuming coolant and chips, turn off the Sump Cleaner.
5. **Discharge Operation:** To return filtered, chip-free coolant to the machine, to wash down the machine, or to discharge coolant into your recycling or disposal system:
 - A. Close the suction inlet valve completely.
 - B. Move the black hose from the suction inlet (on the electrical box housing the motor assembly) to the discharge fitting.



- C. Turn the unit on by placing the on-off-on switch to the “DISCHARGE ON” position.



- D. Depress the handle of the discharge nozzle to begin the fluid flow.
- E. When discharging operation is complete, turn the unit off.
- F. The Sump Cleaner will discharge nearly all the fluid in the bottom of the tank compartment. This is unimportant if the unit remains in reasonably frequent use on a single coolant. If different coolants are used, or the unit will be stored for some time, remove the discharge hose, hose fitting on the bottom of the unit, and drain the unit completely.
6. To empty the Filter Basket:
- Remove lid.
 - Attach an OSHA approved lifting device to the basket rings. CAUTION: All components used to lift the basket (steel cable, hooks, hoist, crane, etc.) must have a minimum capacity of 1,000 pounds or 455 kg.
 - To avoid the basket binding in the tower during removal, position the lifting power source (e.g. crane) directly over the center of the basket.

- Hoist the basket. Keep hands and fingers clear. If the basket is not exiting the center of the tower, return (lower) the basket to chip tower. Reposition the lifting device so that the basket exits the center of the tower.
- DO NOT TOUCH BASKET DURING REMOVAL.**
- Position the basket over the waste receptacle.
- For 50-gallon units, empty contents by inverting the basket using handles welded to the base of the basket. For 65-gallon units and larger, open the basket door by pulling the locking pin cable.
- Once the basket is empty, carefully close the trap door and slide the locking pin into place.
- Check the filter sleeve. If it is badly soiled or clogged, turn it inside out and wash it with a non-solvent cleaning solution. Replace the filter when necessary.
- Inspect the basket hoisting rings for signs of rust. Replace the basket assembly with a new one if the rings are heavily corroded.
- Keeping hands and fingers from under the basket lip, reseal the basket in the tank and fasten down the tank lid.

120V Dual Tank Operation

- Before operating this equipment for the first time, and periodically thereafter, review the SAFETY INFORMATION.
- Suction vacuum and discharge pressure are simultaneously applied to both compartments of this twin compartment unit. Select the compartment to be used by attaching the hoses to the appropriate fittings and cap off the other tank fittings.
- For suction operation to remove dirty coolant and chips from a machine sump:**
 - Plug the electric cord into a 20 AMP grounded 120-volt receptacle.
 - Connect the black hose to the suction port on the electrical box where the motor assembly is located.
 - Open suction inlet valve (S1) fully with suction hose properly attached. Make sure that this valve is either fully open or fully closed at all times. Failure to do so will allow particulate matter to enter the valve seat, which could seize the valve.
 - Make sure that the female quick disconnect caps are on the clean side male fittings and on the dirty side discharge port.
 - Turn on/on toggle switch to the “filter” position so the float switch in the dirty tank is put into the suction circuit.



F. Turn on the Sump Cleaner by placing the “on-off-on” switch into the “SUCTION ON” position. NOTE: The float switch will only work when suction on is selected. It is not wired into the discharge on circuit.

G. Vacuum coolant, chips, and sludge from the machine sump. An electric float located in the tank will rise with the rising liquid level in the tank and shut off the motor when the tank is full. When this occurs, Sump Cleaner will stop sucking.

H. When you are done vacuuming coolant and chips, turn off the Sump Cleaner.

4. For suction operation to fill clean coolant compartment:

- A. Plug the electric cord into a 20 AMP grounded 120 volt receptacle.
- B. Connect the black hose to the suction port on the electrical box containing the motor assembly.
- C. Close valve S-1.
- D. Attach the 1-1/2" hose to the clean coolant compartment inlet port and remove the discharge nozzle.
- F. Attach the nozzle end of this hose to the clean coolant supply tank. Turn on the Sump Cleaner by placing the “on-off-on” switch into the “SUCTION ON” position. NOTE: The float switch will only work when suction on is selected, it is not wired into the discharge on circuit and reattach the discharge nozzle to the hose when full.

E. Place the on/on toggle switch to the “auxiliary” position so the float switch in the clean side of the unit will be in the suction circuit.

5. Discharge Operation to fill a machine tool with clean coolant:

- A. Plug electrical cord into a 20 AMP grounded 120-volt receptacle.
- B. Close valve S1 and connect the black hose to the discharge port on the electrical box where the motor is located.
- C. Connect the 1-1/2" hose to the discharge port. On the clean side, place the discharge nozzle into the machine sump and turn on the unit using the on/off switch. Open the discharge nozzle and fill the coolant sump. Close the nozzle and turn off the sump cleaner when finished.

6. Discharge operation to return filtered, chip-free coolant to the machine to wash down the machine or to discharge coolant into your recycling or disposal system:

- A. Plug electrical cord into a 20 AMP grounded 120-volt receptacle.
- B. Close valve S1 and connect the black hose to the discharge port on the electrical box that contains the motor assembly.
- C. Attach the 1-1/2" hose to the dirty coolant discharge port and place the discharge nozzle into the machine sump.
- D. Turn unit on by using on/off switch.

120V Maintenance Schedule

Weekly	Monthly	6 Months	12 Months	Maintenance Schedule for 120-Volt Electric Motor Sump Cleaner	Maintenance Log					
					Date Placed into Service: Record Date of Service Below:					
				Inspect suction and discharge hoses; replace as needed						
				Inspect filter basket sleeve; replace as needed. Inspect basket lifting rings for corrosion						
				Inspect tank for sludge buildup; clean as needed						
				Grease wheels and casters; use No. 2 bearing grease						

Spare Parts List

120V Push/Pull

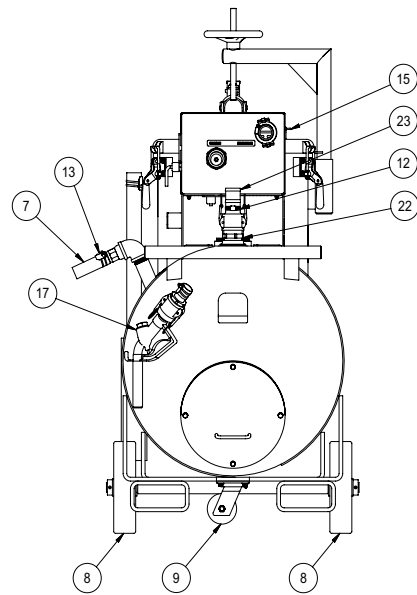
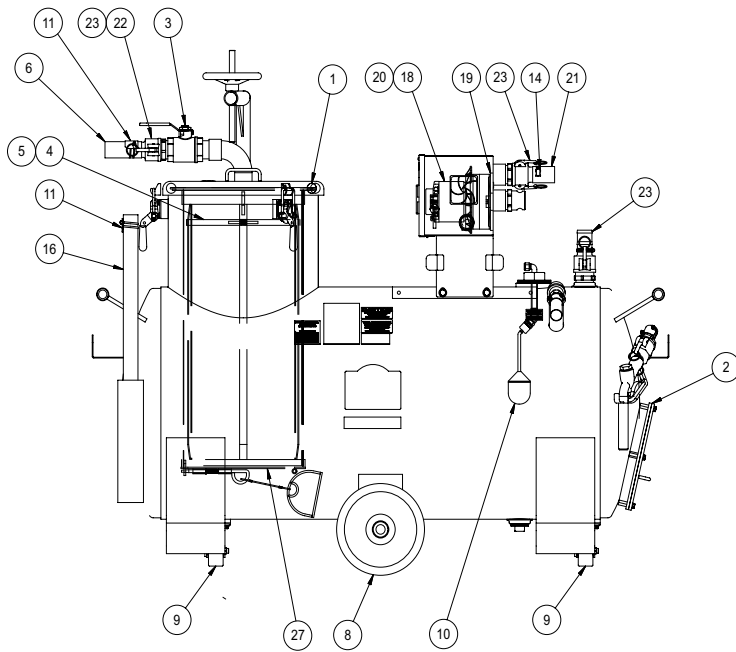
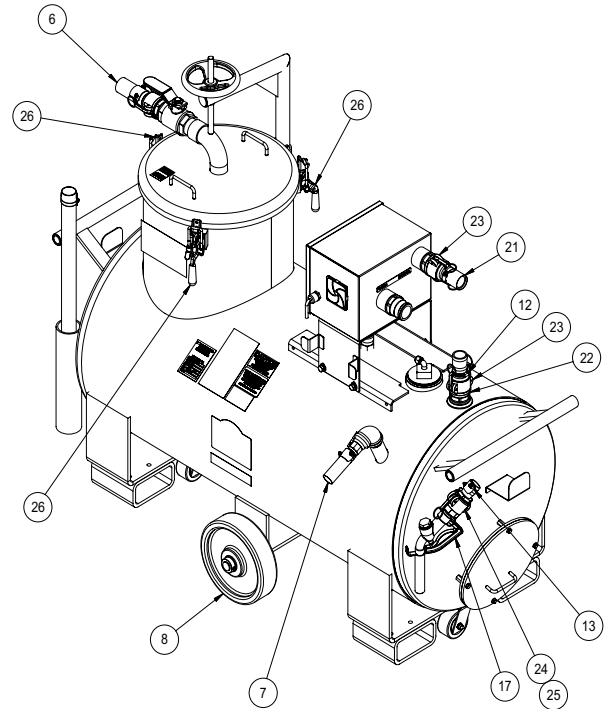
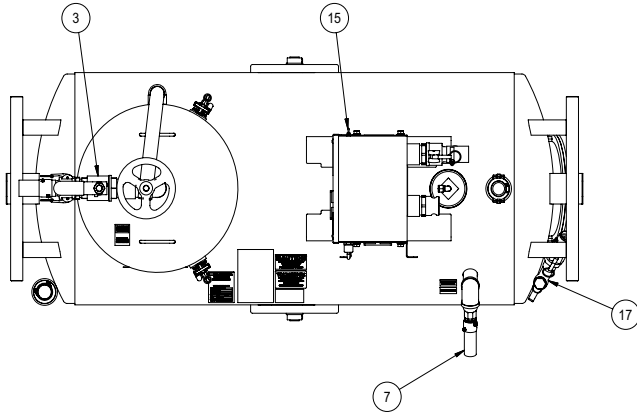

Part #	Stock #	Description
1	60-1560	LID GASKET
2	60-1520	CLEANOUT GASKET
3	25-1400	VALVE 2" NPT BRASS BALL FULL
4	60-1140	BASKET RETAINING RING
5	60-1460	FILTER SLEEVE POLY
6	41-2110	HOSE ORANGE SUCTION 2" ID
7	41-2090	ORANGE DISCHARGE HOSE
8	43-1240	WHEEL 12" X 3" X 1-1/4" PHENOLIC
9	43-1060	CASTER SWIVEL PHENOLIC 4" X 2"
10	38-1160	FLOAT SWITCH
11	41-1010	CLAMP TIGER 2" SPIRAL DOUBLE
12	181004	CLAMP HOSE 24 IDEAL 6424 2 OD
13	41-0980	CLAMP 1-1/2" SPIRAL DOUBLE
14	41-0990	CLAMP HOSE IDEAL 1-3/4" - 2-3/4"
15	30-2235	SWITCH ON/OFF/ON
16	60-1220	TOOL CLEANING ALUM 2" X 36" LG.
17	60-1960	NOZZLE 1" NPT
18	52-1400	MOTOR VACUUM 120V
19	60-1567	GASKET FOAM
20	52-1420	MOTOR BRUSHES
21	41-2230	2" HOSE
22	42-0132	QUICK CONNECT 2" MALE X 2" MNPT
23	42-0133	QUICK CONNECT 2" FEMALE X BARB
24	42-1200	CONNECTOR QD 1-1/2 FEMALE X 1
25	42-1150	QD 1-1/2 MALE X BARB ALUM
26	40-1140	CLAMP
27	60-1080	BASKET ASSEMBLY SLUDGE 36"

Spare Parts List

120V Tow

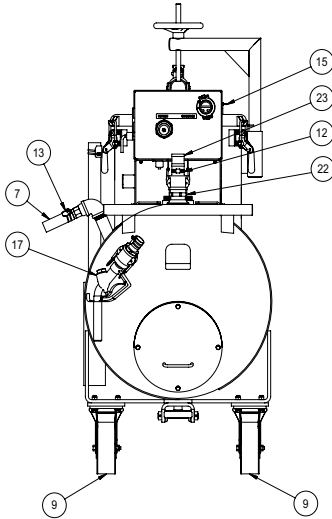
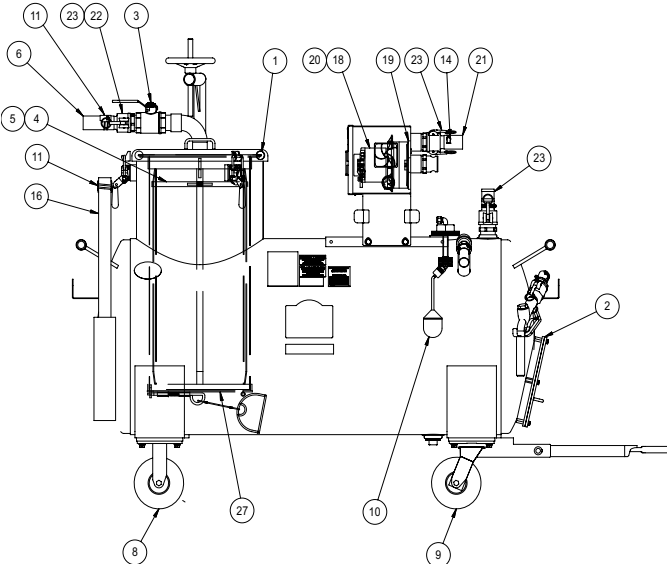
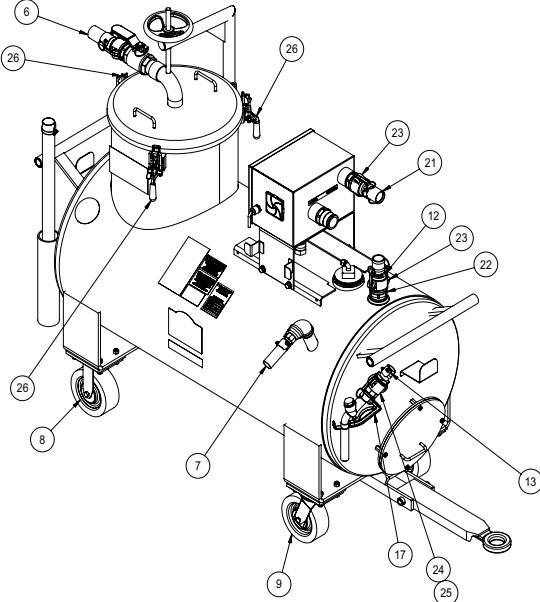
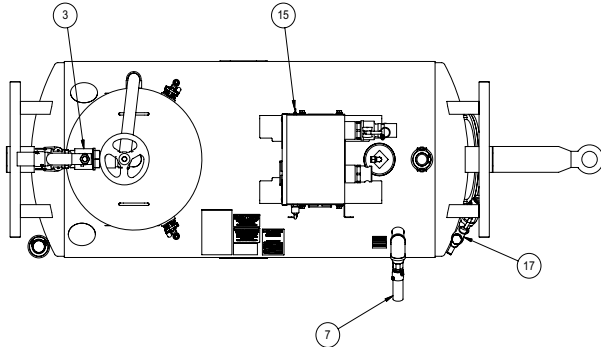

Part #	Stock #	Description
1	60-1560	LID GASKET
2	60-1520	CLEANOUT GASKET
3	25-1400	VALVE 2" NPT BRASS BALL FULL
4	60-1140	BASKET RETAINING RING
5	60-1460	FILTER SLEEVE POLY
6	41-2110	HOSE ORANGE SUCTION 2" ID
7	41-2090	ORANGE DISCHARGE HOSE
8	43-1140	CASTER RIGID URETHANE 8" X 3"
9	43-1160	CASTER SWIVEL URETHANE 8" X 3"
10	38-1160	FLOAT SWITCH
11	41-1010	CLAMP TIGER 2" SPIRAL DOUBLE
12	181004	CLAMP HOSE 24 IDEAL 6424 2 OD
13	41-0980	CLAMP 1-1/2" SPIRAL DOUBLE
14	41-0990	CLAMP HOSE IDEAL 1-3/4" - 2-3/4"
15	30-2235	SWITCH ON/OFF/ON
16	60-1220	TOOL CLEANING ALUM 2" X 36" LG.
17	60-1960	NOZZLE 1" NPT
18	52-1400	MOTOR VACUUM 120V
19	60-1567	GASKET FOAM
20	52-1420	MOTOR BRUSHES
21	41-2230	2" HOSE
22	42-0132	QUICK CONNECT 2" MALE X 2" MNPT
23	42-0133	QUICK CONNECT 2" FEMALE X BARB
24	42-1200	CONNECTOR QD 1-1/2 FEMALE X 1
25	42-1150	QD 1-1/2 MALE X BARB ALUM
26	40-1140	CLAMP
27	60-1080	BASKET ASSEMBLY SLUDGE 36"

3-Phase Electric Models Operation

1. Before operating this equipment for the first time, and periodically thereafter, review the SAFETY INFORMATION.
2. Connect the cleaner to the electric supply specified on the control panel.
 - A. Correct phasing of the electric supply outlets is essential. The Sump Cleaner motor runs in one direction to perform the suction operation, and in the opposite direction for discharge. The float switch in the suction cycle relay holding circuit causes this circuit to drop out at a predetermined liquid level in the tank, preventing overfilling and pump damage. The discharge circuit has no such float switch; therefore, the sump cleaner must be plugged into outlets that are uniformly phased, so that operating the SUCTION button rotates the motor and pump in the correct direction. Connection to improperly phased outlets can void the warranty on this machine.
 - B. Test the outlet phasing by pushing the SUCTION button and verifying whether the cleaning tool is actually vacuuming. If not, the outlet phasing must be modified by authorized service personnel.



3. **Suction operation:** Open the inlet ball valve fully. Press the SUCTION button to start the motor and vacuum coolant and chips from the sump.

4. As soon as fluid stops passing through the hose, press the STOP button to turn off the motor.
 - A. The compartment's maximum capacity is, at most, 10% above the rated capacity. The float switch, located near the component tank suction fitting, will shut off the motor if overfilling starts to occur. If this should happen, follow instructions for the discharge operation in item 5 on page 19.
5. **Discharge operation:** To return filtered chip-free coolant to the sump, wash down the machine, or discharge dirty coolant into your recycling or disposal system, close the suction inlet ball valve. Push the DISCHARGE button and depress the discharge hose nozzle valve.
 - A. Be sure the suction inlet ball valve is fully closed before operating in the DISCHARGE mode!
 - B. **IMPORTANT!** Be sure the suction inlet ball valve is fully closed or fully open, depending on the desired operation (closed-discharge, open-suction). **Failure to do so will allow particulates to enter the valve seat and seize the valve.**
6. Stop the motor as soon as fluid stops passing through the hose.
 - A. The cleaner is to be adjusted and/or repaired only by qualified service personnel. If these personnel need more information than is provided in this manual, they should contact Eriez at 814-835-6000.
 - B. The sump cleaner will discharge nearly all of the fluid in the bottom of the tank. This is unimportant if the compartment is used for one type of coolant only. If different coolants are to be handled in that compartment, remove its drain plug to empty it completely.
7. To empty the filter basket:
 - A. Remove tower lid.
 - B. Attach lifting device to basket rings.
CAUTION: All components used to lift basket (steel cable, hooks, crane, etc.) must have a minimum capacity of 1000 pounds.
 - C. To avoid the basket binding in the tower during removal, position the lifting power source (e.g. crane) directly over the center of the basket.

- D. Hoist the basket. Keep hands and fingers clear. If the basket is not exiting the center of the tower, return (lower) basket to the sump cleaner tower. Reposition the lifting device so that the basket exits the center of the tower.
 - E. DO NOT TOUCH BASKET DURING REMOVAL.
 - F. Position the basket over the waste receptacle.
 - G. Standing clear, open the basket trapdoor by pulling the locking pin cable.
 - H. Once the basket is empty, carefully close the trapdoor and slide the locking pin into place.
 - I. Check the filter sleeve. If it is badly soiled or clogged, turn it inside out and wash it in a suitable cleaner. Replace filter when necessary.
 - J. Inspect the basket hoisting rings for signs of rust. Replace the basket with a new one if the rings are heavily corroded.
 - K. Keeping hands and fingers from under the basket lip, reseal the basket in the tank and clamp down the tank lid.
- 4. Connect the cleaner to the electric supply specified on the control panel.
 - A. Correct phasing of the electric supply outlets is essential. The sump cleaner's motor runs in one direction to perform the suction operation and in the opposite direction for discharge. The float switch in the suction cycle relay holding circuit causes this circuit to drop out at a predetermined liquid level in the tank, preventing overfilling and pump damage. The discharge circuit has no such float switch, therefore, the cleaner must be plugged into outlets that are uniformly phased, so that operating the SUCTION button rotates the motor and pump in the correct direction. Connection to improperly phased outlets can void the warranty on this machine.
 - B. Test the outlet phasing by pushing the SUCTION button and verifying whether the cleaning tool is actually sucking. If not, the outlet phasing must be modified by authorized service personnel.

3-Phase Electric Dual Tank Operation

1. Before operating this equipment for the first time, and periodically thereafter, review the SAFETY INFORMATION.
2. Suction vacuum and discharge pressure are simultaneously applied to both compartments of this twin compartment unit. Select the compartment to be used by attaching the hoses to the appropriate fittings and cap off the other tank fittings.
3. For suction operation: Activate the float switch for the compartment selected by setting the TANK OVERFILL PROTECTION SELECTOR to the corresponding position. This float switch prevents overfilling of the compartment and pump damage during the suction cycle, by causing the suction holding circuit to drop out at a predetermined tank liquid level.
 - 5. **For suction operation:** Open the inlet ball valve, V1, fully. Make sure all female quick disconnect caps are on the male fittings on the clean side and the dirty side discharge port. Place the float switch selector toggle switch on the control panel to the "Filter" position, then press the SUCTION button to start the motor and vacuum coolant and chips from the sump.
 - A. IMPORTANT! Be sure the toggle switch on the control panel is in the Filter position so the float switch in the dirty side will be in the suction circuit to shut the unit off when full. Failure to do so will allow the unit to overfill and spill fluid out the mufflers onto the floor.
6. As soon as fluid stops passing through the hose, press the STOP button to turn off the motor.
 - A. The compartment's maximum capacity is, at most, 10% above the rated capacity. The float switch described in Paragraphs 3 and 4 above, and located near the compartment suction fitting, will shut off the motor if overfilling starts to occur.

- 7. To return filtered chip-free coolant to the sump, or wash down the machine, or discharge dirty coolant into your recycling or disposal system:** close the suction inlet ball valve V1, attach the 1-1/2" hose to the discharge port, place the discharge nozzle in the machine sump, push the DISCHARGE button, and depress the discharge hose nozzle valve.
- A. Be sure the suction inlet ball valve is fully closed before operating in the DISCHARGE mode!
 - B. **IMPORTANT!** Be sure the suction inlet ball valve is fully closed or fully open, depending on the desired operation (closed-discharge, open-suction). Failure to do so will allow particulates to enter the valve seat and seize the valve.
 - C. Stop the motor as soon as fluid stops passing through the hose.
 - D. The sump cleaner will discharge all but about an inch of fluid in the bottom of the compartment. This is unimportant if the compartment cleaner is used for one type of coolant only. If different coolants are to be handled in that compartment, remove its drain plug to empty it completely.
- 8. To fill the clean side with clean fluid:**
- A. Close the suction inlet valve V1, fully, attach 1-1/2" hose to the clean side inlet port, remove the discharge nozzle from the other end of the 1-1/2" hose and attach it to a clean fluid tank, select "Auxiliary" position on the float switch selector toggle switch, and press SUCTION.
 - B. **IMPORTANT!** Be sure the suction inlet ball valve is fully closed or fully open, depending on the desired operation (closed-discharge, open-suction). Failure to do so will allow particulates to enter the valve seat and seize the valve.
 - C. **IMPORTANT!** Be sure the toggle switch on the control panel is in the Auxiliary position so the float switch in the clean side will be in the suction circuit to shut the unit off when full. Failure to do so will allow the unit to overfill and spill fluid out the mufflers onto the floor.
 - D. As soon as fluid stops passing through the hose, press the STOP button to turn off the motor. The compartment's maximum capacity is, at most, 10% above the rated capacity. The float switch described in Paragraphs 3 and 4 above, and located near the compartment suction fitting, will shut off the motor if overfilling starts to occur.
- 9. To discharge clean fluid to refill a machine sump:** close the suction inlet ball valve V1, attach the 1-1/2" hose to the discharge port, place the discharge nozzle in the machine sump, push the DISCHARGE button, and depress the discharge hose nozzle valve.
- A. Be sure the suction inlet ball valve is fully closed before operating in the DISCHARGE mode!
 - B. **IMPORTANT!** Be sure the suction inlet ball valve is fully closed or fully open, depending on the desired operation (closed-discharge, open-suction). Failure to do so will allow particulates to enter the valve seat and seize the valve.
 - C. Stop the motor as soon as fluid stops passing through the hose.
 - D. The sump cleaner will discharge all but about an inch of fluid in the bottom of the compartment. This is unimportant if the compartment cleaner is used for one type of coolant only. If different coolants are to be handled in that compartment, remove its drain plug to empty it completely.



3 Phase Maintenance Schedule

Weekly	Monthly	6 Months	12 Months	Maintenance Schedule for Electric Motor Sump Cleaners	Maintenance Log					
					Date Placed into Service:					
					Record Date of Service Below:					
				Inspect suction and discharge hoses; replace as needed						
				Inspect filter basket sleeve; replace as needed. Inspect basket lifting rings for corrosion						
				Inspect tank for sludge buildup; clean as needed						
				Check blower oil level (add SAE-40 non-detergent oil as needed)						
				Grease blower; (use No. 2 bearing grease - 500 hours)						
				Grease motor bearings (use No. 2 bearing grease)						
				Grease wheels and casters; (use No. 2 bearing grease)						
				Change blower oil; (use SAE-40 non-detergent oil - 1500 hours)						
				Drain blower mufflers if equipped with optional sound reduction mufflers (drain plug is on lower end of muffler)						

Spare Parts List

3-Phase Push/Pull

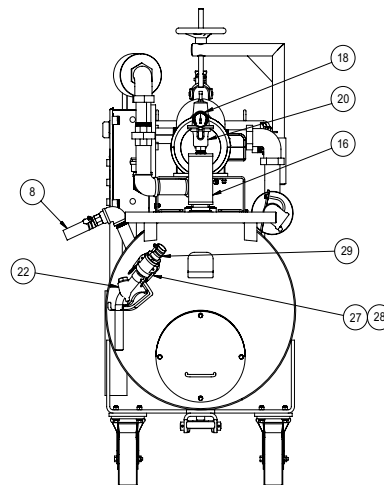
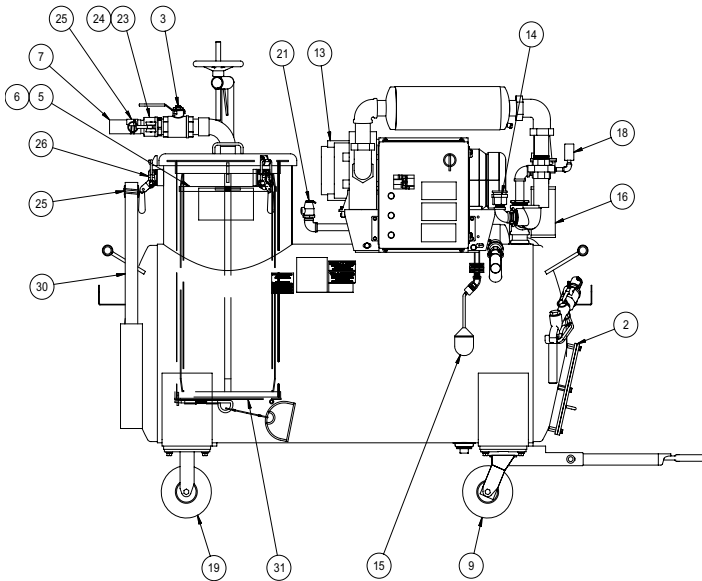
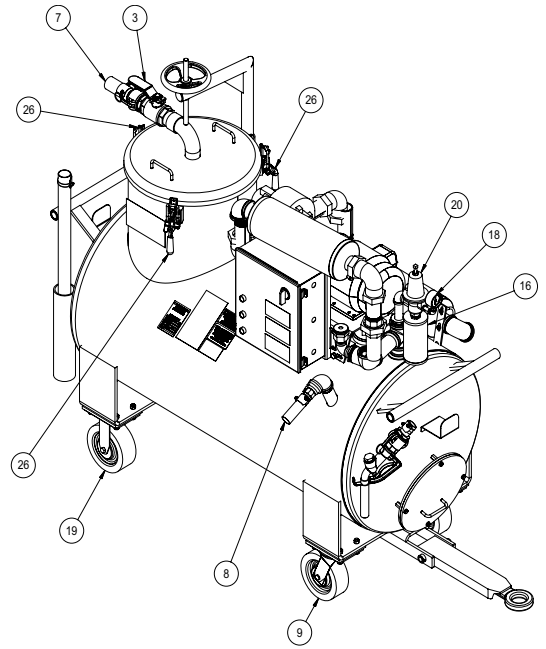
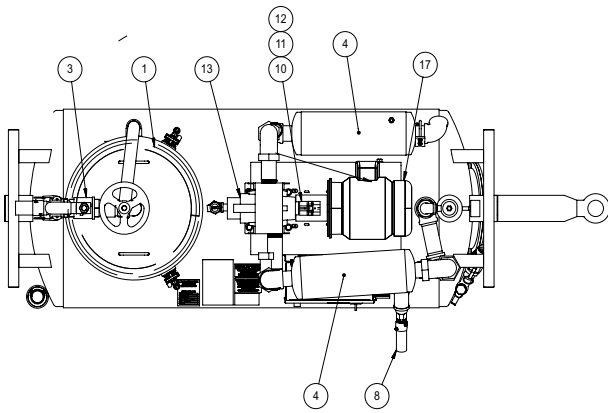

Part #	Stock #	Description
1	60-1560	LID GASKET
2	60-1520	CLEANOUT GASKET
3	25-1400	VALVE 2" NPT BRASS BALL FULL
4	60-1920	MUFFLER ASSEMBLY
5	60-1140	BASKET RETAINING RING
6	60-1460	FILTER SLEEVE POLY - BASKET FILTER
7	41-2110	HOSE ORANGE SUCTION 2" ID
8	41-2090	ORANGE DISCHARGE HOSE
9	43-1160	CASTER SWIVEL URETHANE 8 X 3
10	462641	COUPLING HALF
11	462642	COUPLING HALF
12	462643	COUPLING INSERT
13	54-1040	BLOWER
14	24-1040	VALVE VACUUM RELIEF 1" NPT
15	38-1120	FLOAT SWITCH
16	60-1700	EXHAUST MUFFLER
17	461980	MOTOR
18	29-1160	GAUGE VACUUM-PRESSURE
19	43-1140	CASTER RIGID URETHANE 8 X 3
20	24-1020	VALVE PRESSURE RELIEF
21	467516	VALVE 3/4" LOW PRESSURE
22	60-1960	NOZZLE 1" NPT
23	42-0132	QUICK CONNECT 2 MALE X 2 MNPT
24	42-0133	QUICK CONNECT 2 FEMALE X BARB
25	41-1010	CLAMP TIGER 2"
26	40-1140	CLAMP
27	42-1200	CONNECTOR QD 1-1/2" FEMALE X 1" FNPT
28	42-1150	CONNECTOR QD 1-1/2" MALE X BARB
29	41-0980	CLAMP TIGER 1-1/2"
30	60-1220	TOOL CLEANING ALUM. 2" X 36" LG.
31	60-1080	BASKET ASSEMBLY SLUDGE 36"

Spare Parts List

3-Phase Tow

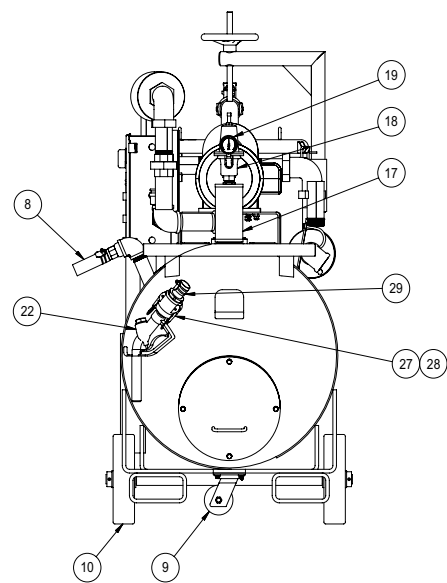
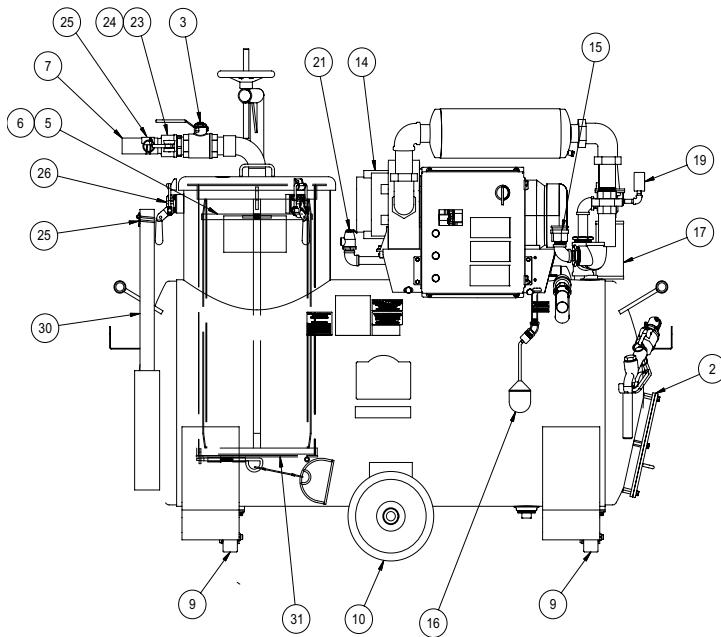
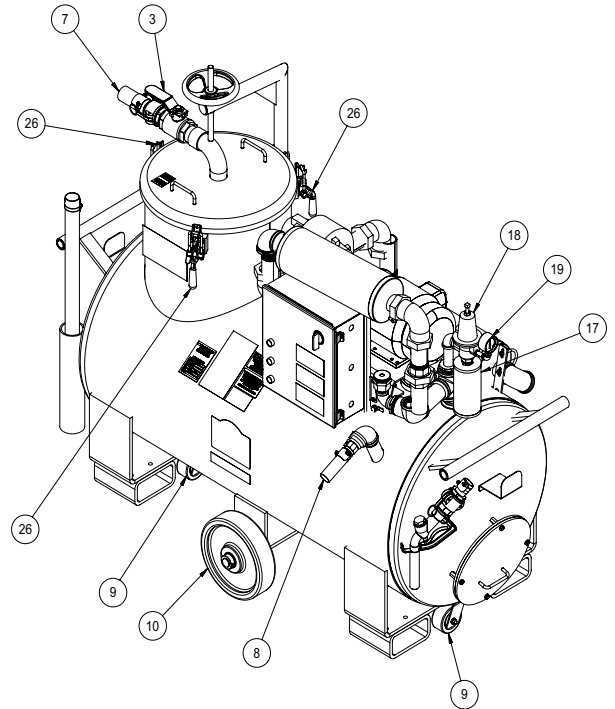
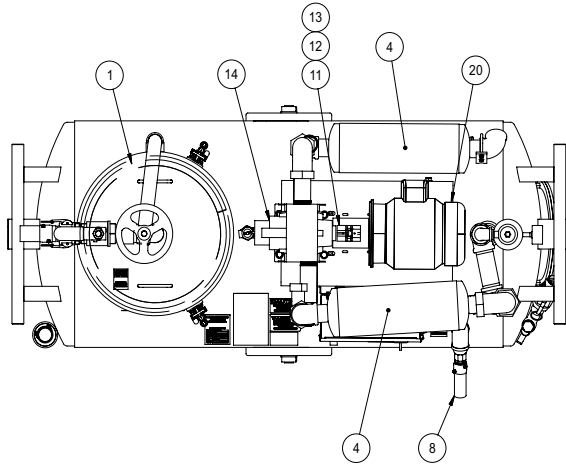

Part #	Stock #	Description
1	60-1560	LID GASKET
2	60-1520	CLEANOUT GASKET
3	25-1400	VALVE 2" NPT BRASS BALL FULL
4	60-1920	MUFFLER ASSEMBLY
5	60-1140	BASKET RETAINING RING
6	60-1460	FILTER SLEEVE POLY - BASKET FILTER
7	41-2110	HOSE ORANGE SUCTION 2" ID
8	41-2090	ORANGE DISCHARGE HOSE
9	43-1060	CASTER SWIVEL PHENOLIC 4" X 2"
10	43-1240	WHEEL 12" X 3" X 1-1/4" PHENOLIC
11	462641	COUPLING HALF
12	462642	COUPLING HALF
13	462643	COUPLING INSERT
14	54-1040	BLOWER
15	24-1040	VALVE VACUUM RELIEF 1" NPT
16	38-1120	FLOAT SWITCH
17	60-1700	EXHAUST MUFFLER
18	24-1020	VALVE PRESSURE RELIEF
19	29-1160	GAUGE VACUUM-PRESSURE
20	461980	MOTOR
21	467516	VALVE 3/4" LOW PRESSURE
22	60-1960	NOZZLE 1" NPT
23	42-0132	QUICK CONNECT 2 MALE X 2 MNPT
24	42-0133	QUICK CONNECT 2 FEMALE X BARB
25	41-1010	CLAMP TIGER 2"
26	40-1140	CLAMP
27	42-1200	CONNECTOR QD 1-1/2" FEMALE X 1" FNPT
28	42-1150	CONNECTOR QD 1-1/2" MALE X BARB
29	41-0980	CLAMP TIGER 1-1/2"
30	60-1220	TOOL CLEANING ALUM. 2" X 36" LG.
31	60-1080	BASKET ASSEMBLY SLUDGE 36"

Maintenance

1. Check the filter basket's polypropylene mesh filter sleeve frequently. If it is badly soiled or clogged, remove the retaining ring beneath the lifting rings, and take off the gasket over the basket's top ring. Lift out the sleeve, turn it inside out and wash it in a suitable cleaner.
2. If the filter sleeve is torn, or if it is soiled or clogged to the point where simple cleaning is inadequate, replace the sleeve with a new one (part number 60-1460).
3. To install a new sleeve: with the basket gasket and retaining ring removed, fit the sleeve inside the basket. Fold the top edge out over the basket's top ring, and snug down the gasket to hold the sleeve in place. Make two small holes in the sleeve over the basket's lifting rings. Pull the rings through. Fit the retaining ring into the basket beneath the lifting rings and tighten it out securely against the basket.

LIFTING RING RETAINING RING TOP GASKET

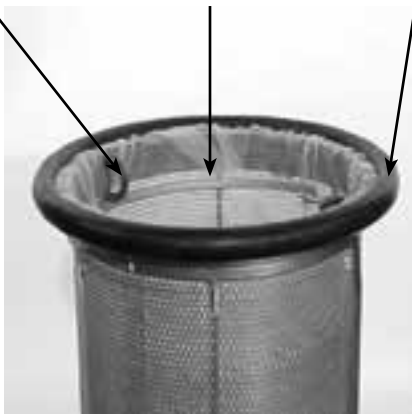

4. Frequently check the basket lifting rings for signs of rust. If the rings become badly corroded, replace the basket with a new one.
5. If the filter sleeve is maintained in good condition, only fine particles should settle out in the bottom of the tank. Remove these periodically by opening the drain plug and with the filter basket out of the sump cleaner, flush the tank with a water hose.
6. Periodically, while the basket is out of the tank, check the tank interior for sludge buildup. If such a buildup starts to thicken, use an appropriate tool to scrape it off the tank walls and out of the cleanout door.

7. On 3-Phase electric and LP gas units, periodically check the pump oil level and fill if required. (See the manufacturer's operating manual provided with your cleaner.)
8. On 3-Phase electric and LP gas units, grease the pump bearings at least every three months. For type of lubricant, see the recommendations in the manufacturer's operating manual provided with this equipment.

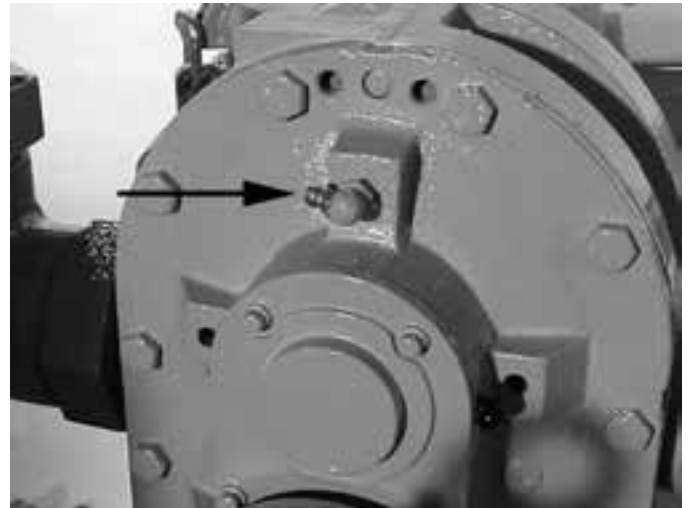

9. On LP units, periodically check the engine oil level and fill if required. (See manufacturer's operating manual provided with your cleaner).
10. Periodically check hoses for deterioration and replace with new ones if leaks have developed or appear imminent. Always coil hoses properly over the supports provided when not in use.
11. Other than the routine maintenance operations specified above, adjustments and/or repairs to this equipment should be undertaken only by authorized service personnel. If these personnel need more information than is provided in this manual, they should contact Eriez at 814-835-6000.

Sump Cleaner Troubleshooting Chart

Problem	Part to Check	Possible Solution
Does Not Start or Run	1. Power Supply	1. On LP units, check for dead battery; on electric units ensure plug is fully seated in wall outlet of the proper voltage
	2. Gas bottle	2. On LP units, make sure gas bottle is not empty, that bottle valve is fully open and that hose is tight.
	3. Float	3. Ensure that float is unobstructed and operating; if tank is full, float switch will not allow unit to start; switch to discharge mode.
	4. Air cleaner	4. On engine-driven units, make sure air cleaner element is clean; clean or replace as needed.
	5. Fuelock filter/regulator	5a. On LP units, faulty fuelock filter or regulator; repair or replace.
		5b. Check o-ring for wear on valve operating pin inside fuelock filter; replace.
	6. Vacuum leak	6. Check vacuum hose and fittings for leaks.
	7. Fuses	7. Check electrical supply system fuses or circuit breakers; replace if necessary.
8. Motor brushes	8. On 120V units, check brushes; replace as needed.	
Insufficient or No Suction	1. Basket	1a. Check for full basket; empty.
		1b. Check if basket liner is blinded off, clean or replace.
	2. Hoses	2a. Check for obstructions; physically remove.
		2b. Check for cracks or holes: replace.
	3. Air leakage	3. Check all hose connections for tightness; make sure female quick disconnect fittings have gaskets in place; check top gasket on filter basket and repair or replace.
	4. Regulator	4. Vacuum regulator could be out of adjustment; contact a Service Technician at Eriez.
	5. Discharge nozzle	5. Check that discharge nozzle is fully closed and in place.
	6. Pneumatic muffler	6. On LP units, ensure pneumatic muffler on four-way valve is not covered with dirt/oils; clean or replace clean or replace.
	7. Blower mufflers	7. Check blower mufflers for oil and coolant first. If plugging: replace.
	8. Air supply	8. On Air Venturi units, check air supply pressure; 100-125 PSI @ 32-47 CFM, 1/2" ID hose required.
9. Air venturi silencer	9. Check silencer on air venturi powerhead for blockage by dirt/oil; clean or replace.	
10. Motor	10. For 120 Volt electric units, check black RFH hose that connects motor to powerhead enclosure and make sure it is tight and has no cracks; replace as needed.	
Insufficient Discharge Pressure	1. Suction valve	1. Check that suction inlet ball valve is fully closed
	2. Regulator	2. Pressure regulator could be out of adjustment; contact a Service Technician at Eriez.



Sump Cleaner Troubleshooting Chart *(cont.)*

Problem	Part to Check	Possible Solution
Will Not Discharge	1. Discharge standpipe	1. Check standpipe for blockage; physically remove obstruction.
	2. Discharge hose	2. Check hose for blockage; physically remove obstruction.
	3. Tank	3. Check for build up of fines and swarf in bottom of tank; clean as necessary.
	4. Pneumatic muffler	4. On LP units, ensure pneumatic muffler is not covered by dirt/oil; clean or replace.
	5. Discharge nozzle	5. Check to see if nozzle is plugged, physically remove obstruction.
	6. Four-way valve	6. On LP units, be sure four-way valve is in discharge position.
	7. Suction valve	7. Be sure suction inlet ball valve is fully closed.
Fluid Dripping from Exhaust Mufflers	1. Float	1. Ensure that electric float is unobstructed and operating.
	2. Discharge ports	2. Check that all discharge ports are fully closed or capped.
	3. Discharge nozzle	3. Be sure discharge nozzle is fully closed.
	4. Tank selector switch	4. On dual compartment units, ensure switch is set for tank in use; improper switch setting will not enable float switch to work.
	5. Foam	5. Check for excessive coolant foaming; call coolant supplier for corrective action.
LP Engine Stalls During Discharge or Suction	1. Engine	1. Check engine RPM; adjust as necessary.
	2. Regulator	2. Pressure or vacuum regulator could be out of adjustment; contact a Service Technician at Eriez.
	3. Pneumatic muffler	3. Ensure pneumatic muffler on four-way valve is not covered with dirt/oils; clean or replace.
	4. LP system	4. Check if LP system is frozen or not working correctly, repair or replace.
Excessive Noise	1. Blower	1. Blower rotors are out of time and knock; replace.
	2. Blower muffler	2a. Check muffler for rust or holes; replace.
		2b. Check mufflers for liquid saturation; drain and dry or replace.
	3. Pneumatic muffler	3. Check to see if pneumatic muffler is rusted out, replace.
	4. Engine muffler	4. Check to see if engine muffler is rusted out; replace.
	5. RPM's too high	5. Check engine RPM for proper speed; adjust engine.
6. Air venturi silencer	6. Check for liquid saturation; drain and dry or replace.	
Portability	1. Hard to push	1a. Check for worn wheels or casters; replace.
		1b. Check wheel and caster bearings: grease or replace.
		1c. Rough Floors: investigate a tow unit or use a forklift to transport.



ELECTRIC SUMP CLEANER 50 GAL. / 120V

Safety Information

SPECIAL NOTE: To avoid personal injury, before operating a 120 volt electrically powered sump cleaner, the customer must connect the 3-wire electrical cord to a suitable power supply that is also properly grounded. the green wire in the electrical box of the sump cleaner is the ground wire. the customer's ground source must be in accordance with article 250 of the national electric code (nec) or other suitable regulation if in a country other than the united states of america.

1. To avoid possible injury, before operating this Sump Cleaner, read this manual for full operating instructions.
2. Always block the wheels of the Sump Cleaner to prevent unintentional rolling. Accidental rolling on a sloped floor, if bumped, could cause injury or property damage.
3. Wear eye goggles to protect your eyes from splashing liquids. This is important, even when you know the fluids themselves are not caustic or otherwise harmful. Metal particles suspended in the liquid could still cause serious eye injury.
4. Check hose, nozzle, cleaning tool, and hose cap connections for leaks. To minimize chances of spilling, handle cleaning tools and hoses carefully during operation, and replace hoses before deterioration results in leaks.
5. Immediately clean up any spilled coolant to avoid slippery floors and dangerous falls.
6. If it is necessary to use the Sump Cleaner in an aisle or other traffic area, position it to minimize the likelihood of being struck by trucks, forklifts or other equipment in transit. Exercise a reasonable lookout for such hazards during operation.
7. Whenever removing or reseating the filter basket (maximum chip/sludge capacity is approximately 200 to 300 pounds, or 90 to 136 kg), keep hands and fingers out from under the basket lip.
8. Keep clear from beneath the basket when trying to empty its contents, or if necessary, to pull out the polypropylene liner. Use tools of appropriate strength and length to let you perform these operations safely.
9. Frequently check the basket's hoisting rings for signs of rust. If the rings are heavily corroded, replace the basket with a new one.
10. Be sure the suction inlet ball valve (S1) is fully closed before operating the Sump Cleaner in the discharge mode. The tank is pressurized in this mode, sometimes to as much as four to five PSIG.
11. The electric motor on your cleaner is designed to be used only with the electric supply specified on the Specifications Page of this manual, and on the motor enclosure. Use with any other type of connection or power source may damage the equipment or cause personal injury.
12. **Do NOT use this unit for solvents, flammable cleaners (low flash point) or other volatile liquids.** Use it only for water-soluble coolants and for cutting or grinding oils.
13. Operating temperature of standard suction and discharge hose is 150°F.
14. This equipment is to be operated and maintained by authorized personnel only.
15. **MAGNESIUM CHIPS OR DISSIMILAR METALS.** In the presence of water, magnesium can release hydrogen gas, which is highly flammable and, in the proper proportions with air, can be explosive.

When a Sump Cleaner is used on a metalworking fluid application generating magnesium chips, certain precautions must be taken to ensure that any hydrogen gas is dissipated into the atmosphere and to make sure the hydrogen does not accumulate in the Sump Cleaner.

This is accomplished by promptly removing any magnesium chips from the Sump Cleaner basket. In addition, a maintenance schedule should be established by the customer that would eliminate buildup of sludge in the bottom of the Sump Cleaner. Finally, the unit should be stored with the basket empty of chips, the chip basket lid removed, the coolant discharge nozzle removed and hoses open to the atmosphere. Taking these precautions will minimize the risk of hydrogen gas generation and accumulation.

CAUTION: All components used to lift the basket (steel cable, hooks, crane, etc.) must have a minimum capacity of 1,000 pounds (455 kg).

On an application where dissimilar metals are machined, there is a chance for spontaneous combustion to occur. Typically, metalworking facilities that machine various metals are aware of this and may have experienced problems in chip hoppers due to the presence of two or more metals, water, and tramp oil. The precautions mentioned in this paragraph will minimize or eliminate the potential for spontaneous combustion.

Pressurization Safety Issues

Your Sump Cleaner is designed to operate under pressure when discharging fluids. The optimal safe operating pressure should always be less than 7 PSI and your unit was set at below this level at the factory. Your unit should never be operated at pressures exceeding factory settings. Tanks or vessels, which are pressurized beyond this pressure, require ASME certification as "Pressure Vessels" and the Sump Cleaner has not been certified for such high-pressure operation. Operating a Sump Cleaner at pressures above this creates a serious risk of injury to workers and damage to property.



WARNING

Altering or modifying safety regulating features to defeat them may result in the tank becoming over pressurized. Over pressurization may cause the explosive rupture of the tank resulting in serious injury or death to workers and damage to property. Modifying or intentionally defeating these important safety features will constitute the intentional misuse of the equipment voiding all warranties.

The Sump Cleaner is to be adjusted and/or repaired only by qualified service personnel. If these personnel need more information than is provided in this manual, they should contact Eriez at 814-835-6000.

Warranty

Eriez equipment warranty is defined in Eriez standard Terms and Conditions of Sale provided at the time of invoice and also available on www.eriez.com or by contacting Eriez. Equipment warranty includes all sump cleaners and is subject to the following exceptions and clarifications:

1. Gasoline and LP Gas internal combustion engines are not covered by Eriez warranty but rather are covered by the standard warranty of the engine manufacturer, which varies from model to model. Copies of the specific warranty of the manufacturer will be shipped with the unit and such warranties and limitations are incorporated by reference herein. Upon request, copies of the engine manufacturer's warranty will be provided in advance of shipment.
2. For units mounted on mobile platforms or other similar sub-assemblies, such as trucks, carts, or self-propelled platforms, Eriez makes no warranties for such sub-assemblies manufactured by third parties and specifically disclaims any warranties with regard thereto, including implied warranties of merchantability or fitness for a particular use. The only warranties as to such sub-assemblies are those extended to purchaser directly by the third-party manufacturer, and such warranties are subject to all of the terms, conditions, and limitations of the third party's warranties and are enforceable only against said third-party manufacturer; and Eriez is not underwriting or guaranteeing their warranties, nor is Eriez an agent of said third-party manufacturers for purpose of pursuing warranty claims or making service arrangements or any other purpose. Copies of such third-party sub-assembly manufacturers' specific warranty information will be shipped with the unit, and such warranties and limitations are incorporated by reference herein. Upon request, copies of sub-assembly manufacturers' warranty information will be provided in advance of ordering or shipment.
3. On all units, including Sump Cleaners and other sump cleaning equipment, all gaskets, hoses, filter basket-sleeves, cleaning tools, wheels, casters and batteries are considered expendable or ordinary maintenance items and are expressly exempted from this warranty and are not covered by any other warranty, express or implied.
4. Component parts returned for replacement must show the original unit serial number from which they were removed. Parts returned without the aforementioned serial number will be replaced at established replacement prices. Vacuum and pressure relief valves are preset at the factory. ALTERATION OF THE SETTING EXCEPT WITH THE SPECIFIC AUTHORIZATION OF ERIEZ OR ITS AUTHORIZED REPRESENTATIVES WILL VOID FACTORY WARRANTY.



Assembly

1. Refer to the drawings at the end of this manual for location of the items discussed below and the following sections of this manual.
 2. Remove the cover of the basket. Keep hands and fingers from under the edges of the filter basket.
 3. Take out the following items:
 - a. Filter basket.
(Factory assembled with filter sleeve).
 - b. Spare filter sleeve and two paper filter bags.
 - c. Discharge hose with nozzle.
 - d. Suction hose.
 - e. Cleaning tool (from metal tube on tank body). Keeping hands and fingers out from under the edge of the basket, reseal the basket filter inside the unit. Replace the tank lid and clamp it down with the swing bolts provided.
 4. Attach the suction hose to the intake connection on the tank lid. Attach the cleaning tool to this hose, and coil the hose around the basket end of the unit. The cleaning tool easily stows in the metal tube provided.
 5. Couple the discharge hose to the discharge connection, and coil the hose over the support provided on the opposite end of the machine. Attach the discharge nozzle to the discharge hose with the quick-disconnect coupling provided.
- b. Open suction inlet valve (S1) fully with suction hose properly attached. **MAKE SURE THAT THIS VALVE IS EITHER FULLY OPEN OR FULLY CLOSED AT ALL TIMES. FAILURE TO DO SO WILL ALLOW PARTICULATE MATTER TO ENTER THE VALVE SEAT, WHICH COULD SEIZE THE VALVE.**
 - c. Make sure that the discharge hose is connected, and that the discharge nozzle is attached and closed.
 - d. Turn on the Sump Cleaner by placing the “on-off-on” switch into the “SUCTION ON” position. **NOTE: THE FLOAT SWITCH WILL ONLY WORK WHEN SUCTION ON IS SELECTED, IT IS NOT WIRED INTO THE DISCHARGE ON CIRCUIT.**
 - e. Vacuum coolant, chips, and sludge from the machine sump.
 - f. An electric float located in the tank will rise with the rising liquid level in the tank and shut off the motor when the tank is full. When this occurs, Sump Cleaner will stop sucking.
 - g. When you are done vacuuming coolant and chips, turn off the Sump Cleaner.
5. Discharge Operation: To return filtered, chip-free coolant to the machine, to wash down the machine, or to discharge coolant into your recycling or disposal system:
 - a. Close the suction inlet valve (S1) completely.
 - b. Move the black hose from the suction inlet (on the electrical box housing the motor assembly) to the discharge fitting.
 - c. Turn the unit on by placing the on-off-on switch to the “DISCHARGE ON” position.
 - d. Depress the handle of the discharge nozzle to begin the fluid flow.
 - e. When discharging operation is complete, turn the unit off.
 - f. The Sump Cleaner will discharge nearly all the fluid in the bottom of the tank compartment. This is unimportant if the unit remains in reasonably frequent use on a single coolant. If different coolants are used, or the unit will be stored for some time, remove the discharge hose, hose fitting on the bottom of the unit, and drain the unit completely.

Operation

1. Before operating this equipment for the first time, and periodically thereafter, review the SAFETY INFORMATION.
2. Suction vacuum and discharge pressure are applied independently in this unit by moving a hose attached to the tank to either the suction fitting or the discharge fitting as required.
3. Connect the Sump Cleaner to the electrical supply specified on the electrical box housing the motor. For North America, this is 120 VAC, single phase, 60 Hz.
4. Suction Operation:
 - a. Connect the black hose to the suction port on the electrical box containing the motor assembly.

6. To empty the Filter Basket:
 - a. Remove lid.
 - b. Attach an OSHA approved lifting device to basket rings. **CAUTION:** All components used to lift the basket (steel cable, hooks, hoist, crane, etc.) must have a minimum capacity of 1,000 pounds or 455 kg.
 - c. To avoid the basket binding in the tower during removal, position the lifting power source (e.g. crane) directly over the center of the basket.
 - d. Hoist the basket. Keep hands and fingers clear. If the basket is not exiting the center of the tower, return (lower) basket to the Sump Cleaner tower. Reposition the lifting device so that the basket exits the center of the tower.
 - e. **DO NOT TOUCH BASKET DURING REMOVAL.**
 - f. Position the basket over the waste receptacle and lower until in contact with material in waste receptacle.
 - g. Tip the basket on its side and over to empty. The handle on the bottom of the chip basket can be used to assist with this effort.
7. Check the filter sleeve. If it is badly soiled or clogged, turn it inside out and wash it with a non-solvent cleaning solution. Replace filter when necessary.
8. Inspect the basket hoisting rings for signs of rust. Replace the basket assembly with a new one if the rings are heavily corroded.
9. Keeping hands and fingers from under the basket lip, reseal the basket in the tank and fasten down the tank lid.

THE SUMP CLEANER IS TO BE ADJUSTED AND/OR REPAIRED ONLY BY QUALIFIED SERVICE PERSONNEL. IF THESE PERSONNEL NEED MORE INFORMATION THAN IS PROVIDED IN THIS MANUAL, THEY SHOULD CONTACT ERIEZ.

Operating Efficiency Tips

Note: Extremely fine grinding particles, such as carbide grinding swarf, will pass through even the paper filter. Although the Sump Cleaner will do an excellent job of removing the swarf from the grinder, you will experience a rapid accumulation of fines in Sump Cleaner tank.

- If you are experiencing a problem in disposing of chips or swarf because of too great a moisture content, your Sump Cleaner can be used as a chip “drier”. Vacuum out your machine to remove all chips, fines, and then empty the Sump Cleaner of all coolant in the normal manner. Open the suction inlet ball valve, start the unit in the suction mode, and allow it to run for 10 to 15 minutes. Air drawn into the Sump Cleaner will draw excess moisture from the chips and allow them to be disposed of more easily. Be prepared to experiment with drying times; getting the chips or swarf too dry will make it difficult to remove them from the filter basket.
- Always empty the filter basket immediately after using the Sump Cleaner. Allowing the chips or swarf to remain in the basket and the basket in the unit overnight or over the weekend can cause the chips or swarf to corrode (rust) into a solid mass which is virtually impossible to remove from the basket. This problem is especially pronounced with cast, nodular and malleable irons.
- Do NOT alter the unit’s vacuum and pressure settings. You will not improve your Sump Cleaner’s performance and you will void its warranty.
- Do NOT use your unit for solvents, volatile or low flash point fluids of any type. It is designed for use with coolants, cutting oils, water-soluble machine cleaning solutions and parts washing compounds only.
- When pumping out of below-floor-level pits you can increase the efficiency of the suction by drilling a small hole (3/16", or 4 mm) in the pickup tube below where the hose is attached at the cuff.

By keeping this hole above the fluid level, you allow more air to enter the hose. That helps to move the fluid up the hose faster and allow pumping out of deeper pits.

If you have any questions about your unit or its suitability for a particular job, please contact Eriez at 814-835-6000.



Maintenance

1. Check the filter basket's polypropylene mesh filter sleeve frequently. If it is badly soiled or clogged, remove the retaining ring on the inside of the basket. Lift out the sleeve, turn it inside out, and wash in a suitable cleaner.
2. If the filter sleeve is torn, or if it is soiled or clogged to the point where simple cleaning is inadequate, replace the sleeve with a new one.
3. To install a new sleeve fit the sleeve inside the basket, and fold the top edge over forming a smooth edge. Make two small holes in the sleeve in order to slide it over the basket's lifting rings. Push the rings through.
4. Frequently check the basket lifting rings for signs of rust. If the rings become badly corroded, replace the basket with a new one.
5. If the filter sleeve is maintained in good condition, only fine particles should normally settle out in the bottom of the tank. Remove these periodically by removing the discharge hose at the 90° elbow, and with the filter basket out of the Sump Cleaner, flush the tank with a water hose.
6. Periodically, while the basket is out of the tank, check the tank interior for sludge buildup. If such a buildup starts to get thick, use an appropriate tool to scrape it off the tank walls. Remove the discharge hose and hose fitting from the bottom of the tank, and flush the tank with a water hose.
7. Periodically, check hoses for deterioration, and replace with new ones if leaks have developed or appear imminent. Always coil hoses properly over the supports provided when not in use.

Other than the routine maintenance operations specified above, only authorized service personnel should undertake adjustments and/or repairs to this equipment. If these personnel need more information than is provided in this manual, they should contact Eriez at 814-835-6000.

Maintenance Schedule

Weekly	Monthly	6 Months	Maintenance Schedule for Electric Sump Cleaners	Maintenance Log					
				Date Placed into Service: Record Date of Service Below:					
			Inspect suction and discharge hoses. Replace as needed						
			Inspect filter basket sleeve and replace as needed. Inspect basket lifting rings for corrosion.						
			Inspect tank for sludge buildup; clean as needed						
			Grease wheels and casters; use no. 2 bearing grease						

Sump Cleaner - Electric - 120 Volt Troubleshooting Chart

Problem	Part to Check	Possible Solution
Unit does not start	Power supply	Make sure that the plug is fully seated in a wall outlet of proper voltage
	Fuses	Check electrical supply system fuses or circuit breakers. Replace if necessary
	Motor brushes	Check brushes; replace as needed
Insufficient suction or no suction	Basket	Check for full basket; empty Check if basket is blinded off; clean or replace
	Hoses	Check for obstructions; physically remove. Check for cracks or holes; replace
	Air leakage	Check all hose connections for tightness. Make sure female quick disconnect fittings have gaskets in place. Check top gasket on filter basket and repair or replace.
	Discharge nozzle	Check that discharge nozzle is fully closed and in place
Insufficient discharge pressure	Suction valve	Check that suction inlet ball valve is fully closed
Will not discharge	Discharge hose	Check hose for blockage. Physically remove obstruction
	Tank	Check for build up of fines and swarf in bottom of tank. Clean as necessary.
	Discharge nozzle	Check to see if nozzle is plugged. Physically remove obstruction.
	Suction valve	Be sure suction inlet ball valve is fully closed.
Portability	Hard to push	Check for worn wheels or casters; replace. Check wheel and caster bearings; grease or replace. Rough floors; use a forklift truck for transport.



Spare Parts List

50 Gallon - Electric - 120V

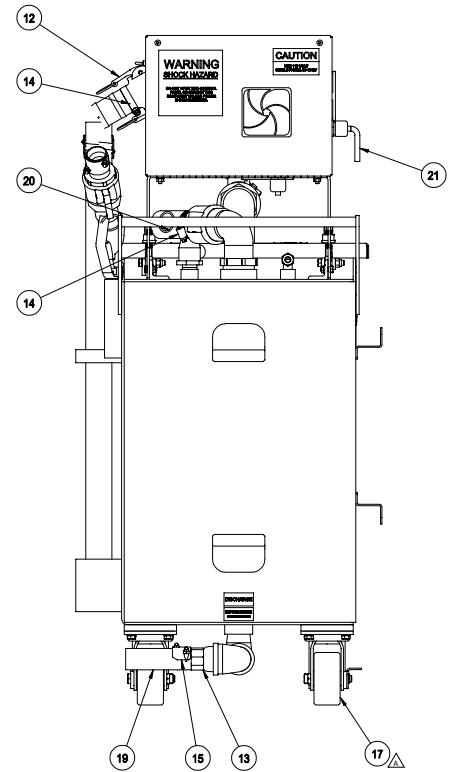
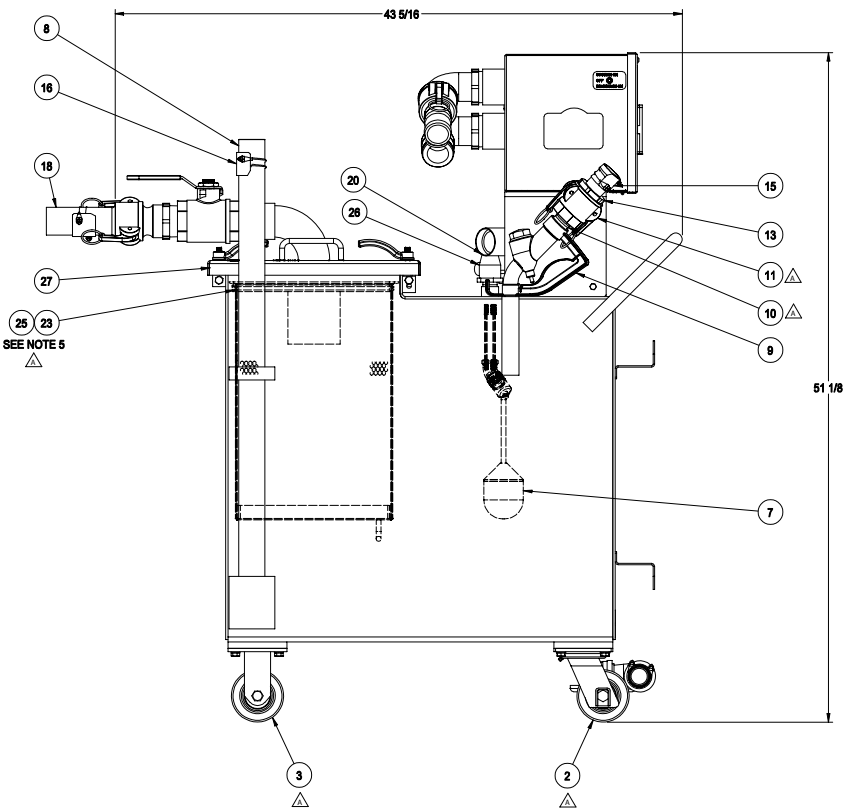
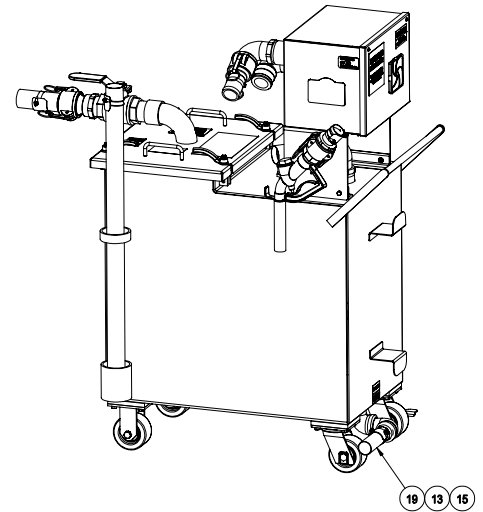
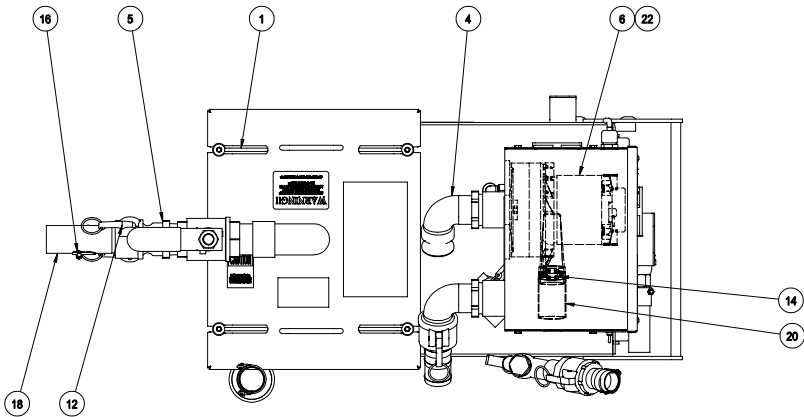

Part #	Stock #	Description
27	463031	Lid Gasket
26	467449	Safety Relief Valve
25	*60-1450	Liner for Strainer Basket
23	*31-3270	Ty-Rap Cable
22	52-1420	Motor Brushes (Spares)
21	30-2055	Power Cord
20	41-2230	Black Hose 2"/2 ft long
19	41-2090	Orange Hose 1.5"/10 ft long
18	41-2110	Orange Hose 2"/10 ft long
17	43-1040	Swivel Caster with Brake
16	41-1010	Spiral Hose Clamp
15	41-0980	Spiral Hose Clamp
14	41-0990	Hose Clamp
13	42-1140	Quick Disconnecting Fitting
12	42-0133	Quick Connect Poly Fitting
11	42-1200	Quick Disconnect Aluminum Fitting
9	60-1960	Gas Nozzle
8	60-1220	Cleaning Tool
7	38-1160	Float Switch
6	52-1400	Motor, Vacuum 120V
5	42-0132	Quick Connect Poly Fitting
4	42-0146	Quick Disconnect Poly Elbow
3	43-1020	Rigid Caster
2	43-1060	Swivel Caster
1	40-1150	Adjustable Handle

* = Recommended to purchase as a set.



DRUM TOP SUMP CLEANER MODEL 90-1020

Assembly

Model 90-1020

1. Remove the jumbo cover assembly from box, and attach legs (#04997) to bottom of the cover.
2. Install the deflector 60-1400 (#90442) to the bottom of the cover.
3. Install one tank cover plug assembly (#14395) to one of the powerhead adapters 54-1160 (#14415) on the jumbo cover 60-1320. If a jumbo cover liquid shutoff is being used, do not plug the adapter above the float assembly.
4. Install the jumbo cover liquid shutoff 38-1142 (#90569) to the bottom of the cover (this is an optional item, not all units will be equipped with this).
5. Install the 2" hose adapter 60-1000 (#90332) into the 2" pipe at a 45 degree angle on top of the jumbo cover.
6. Install the venturi powerhead 54-1140 (#95990) on the jumbo cover by inserting into the powerhead adapter and turning it 1/4 turn.
7. Install the 1/2" NPT close nipple into the powerhead.
8. Attach the 1/2" NPT ball valve to the pipe nipple.
9. Install assembly on an open top 55-gallon drum. Drum must be in good condition with no dents or other defects to the drum or the drum will collapse under vacuum. A drum with a side 2" NPT bung will allow adding a drain valve to drain off fluid if desired.
10. Attach an air line fitting to the ball valve.
11. Install the hose on to the hose adapter.
12. Insert the 60-1220 cleaning tool into the hose.

Operation

Model 90-1020

1. Attach a compressed air line to the ball valve. 1/2" I.D. airline hose is required for maximum suction. These units require 60-90PSI and 32-47 CFM to be able to perform properly.
2. Open ball valve. This will create a vacuum in the drum and at the end of the hose.
3. Use the cleaning tool to pick up solids, chips or fluids which will be sucked into the drum.
4. When the drum is full, it must be emptied into a waste tank, chip hopper, or any suitable vessel.



Eriez and Eriez Magnetics are registered trademarks of Eriez Manufacturing Co, Erie, PA

©2019 Eriez All Rights Reserved



World Authority in Separation Technologies

Headquarters: 2200 Asbury Road, Erie, PA 16506-1402 U.S.A.

Telephone: 814-835-6000 • Fax: 814-838-4960

www.eriez.com e-mail: eriez@eriez.com



Manufacturing Facilities: AUSTRALIA • BRAZIL • CANADA • CHINA • INDIA • JAPAN • MEXICO • SOUTH AFRICA • UNITED KINGDOM • UNITED STATES