

ERIEZ Quick Ship Equipment Catalog





Eriez' ProGrade® magnetic separators offer a solution for every process application. Whether you need a low cost plate magnet for equipment protection or a high power sanitary grate magnet to ensure product purity, ProGrade gives you the best for less. Three levels of ProGrade magnets are available in grate, plate, tube, and trap assemblies.

X8 Metal Detector

X8 Metal Detector Quick Ship program is designed to match stocked conveyors and Metal Detector apertures for fast delivery. Eriez stocks our most popular sized metal detector apertures and 4 stainless steel, wash down conveyor widths for quick assembly and delivery as well as select vertical and liquid line systems.

FEEDERS FAST

Feeders Fast offers nearly 40 feeder models using stock components, available for shipment within five days. These quick-ship, electromagnetic vibratory feeders from Eriez are AC powered making them extremely reliable and energy efficient – ideal for many sanitary, industrial and process applications. Compact feeders up to 20 TPH are available in tray sizes up to 16 inches wide and 60 inches long. Heavy-Duty feeders now available in 4 models with capacities from 70 to 270 TPH.

WHEN YOU NEED IT NOW!

Can't wait for a solution to a challenging problem? The most popular Eriez products are now ready for next-day shipment through the **EriezXpress™** program.

Eriez stocks its most popular items for immediate needs, many for next-day shipment.

EriezXpress™

Eriez has grown its stocking program to cover many of our most popular items from grate magnets to vibratory feeders and metal detectors. Many of these quick-ship items are available in three convenient designations: Next-Day, 5-Day and 10-Day shipment.

10-Day Express Shipment

Six of our most popular manual cleaning SE-7000 Series Suspended Electromagnet models are available for express assembly in 10 days. These magnets range from 42 to 78 inches wide, offering a size to meet typical conveyor widths and include options for suspension style, junction box rating, high elevations and oil type.



ERIEZ Global Leader in Separation Technologies

Table of Contents

Magnetic Separators

Tube Magnets • Grates • Grate-In-Housing
Pneumatic • Liquid Line Trap Separators
Plates • Inspection Tubes • Handheld
Pull Test Kits • Suspended Magnets • Controls

4-19



Metal Detectors

Aperture/Conveyors • Liquid Line
Vertical • Handheld

20-23



Vibratory Equipment

Feeders • Bin Vibrators
Rotary Vibrators • Controls

24-30



Have questions? Contact our sales team at 814.835.6000 or visit eriez.com for more information.





Eriez' magnetic separators offer a solution for every process application. Whether you need a low cost plate magnet for equipment protection or a high power, sanitary grate magnet to ensure product purity, Eriez gives you the best for less. Three levels of magnet strength are available in grate, plate, tube and trap assemblies.



Magnetic Separators

ProGrade Ceramic

Protection from large tramp metals damaging downstream equipment. Ceramic magnets and quality construction at low prices.

ProGrade Rare Earth

Prevents product contamination and small tramp metal damage. Assemblies feature stainless steel construction, high-power rare earth magnets with demanding attention to welds and finish.



The ultimate protector of process purity combines the finest materials and construction techniques with the industry's most powerful RE7 Xtreme Rare Earth magnetic circuits.

Designed to Remove



Medium to Large Tramp Metal



Small Ferrous Contamination



Weakly Magnetic Fine Ferrous Contamination

Tube Magnets

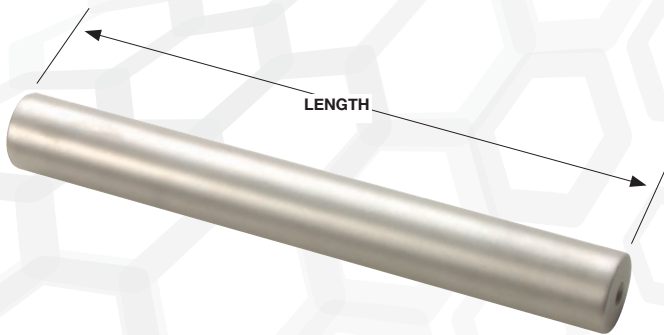

Individual magnetic tubes, 1 inch (25 mm) in diameter and from 4 inches (100 mm) up to 24 inches (610 mm) long, can be used to remove ferrous contaminants from liquids in tanks, as a quality control check of dry bulk materials and in many other ways where a powerful, portable magnetic power source is needed. All magnetic tubes are available with 1/4-20 UNC drilled and tapped end plugs.

FEATURES:

- 1 inch diameter
- Continuously welded
- 316L stainless steel
- 1/4-20 tapped end plugs
- Glass bead surface finish
- Rare Earth and Xtreme Rare Earth Magnet Circuits for temperatures up to 150°F



Length		Ceramic	Rare Earth	RE7 Xtreme Rare Earth
in	mm	Part No. (Weight lbs)	Part No. (Weight lbs)	Part No.
4	102	135708P (0.7)	126734P (0.8)	150571P
6	152	133640P (1.0)	132640P (1.2)	150561P
8	203	133642P (1.3)	126725P (1.7)	150572P
10	254	133644P (1.7)	126728P (2.2)	150573P
12	305	133646P (2.0)	126727P (2.6)	150563P
14	356	133648P (2.3)	133567P (3.0)	150574P
16	406	134057P (2.6)	130919P (3.4)	150575P
18	457	134059P (2.9)	130920P (3.9)	150565P
20	508	135709P (3.2)	140820P (4.3)	150576P
22	559	135710P (3.5)	135684P (4.7)	150577P
24	610	140764P (3.8)	126748P (5.1)	150578P

All prices and specifications are subject to change without notice. Terms and conditions of sale are available at www.eriez.com.

Grate Magnets

SQUARE & RECTANGULAR

Square and rectangular Permanent Magnetic Grate Magnets remove ferrous contamination in hoppers, chutes, floor openings and other areas where free flowing materials are present. These grate magnets are also constructed to fit square and odd-shaped hoppers. The all-stainless steel unit is installed by simply placing the grate in the hopper with the ends of the magnetic tubes or tie bars resting against the sides.

FEATURES:

- All stainless steel construction
- 1 inch diameter tubes on 2 inch centers
- Sanitary construction (Xtreme Rare Earth only)
- Glass bead surface finish
- 150°F Max Temp (Rare Earth and Xtreme Rare Earth)

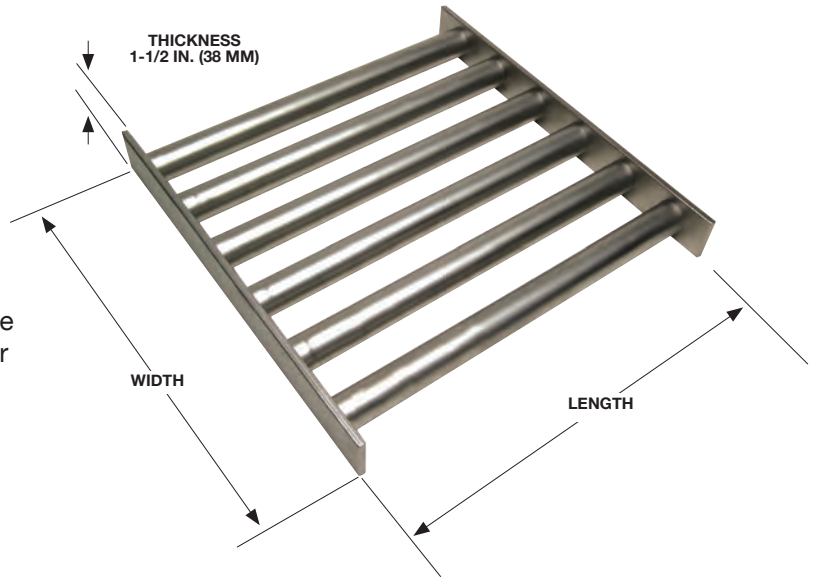

CERAMIC

Width x Length		Weight lbs	Part No.
in	mm		
6 x 6	152 x 152	4.0	135717P
8 x 8	203 x 203	6.4	135665P
10 x 6	254 x 152	6.2	135718P
10 x 10	254 x 254	9.7	135719P
12 x 8	305 x 203	8.6	135720P
12 x 12	305 x 305	13.7	135669P
16 x 12	406 x 305	18.1	135721P
14 x 14	356 x 356	18.1	135722P

RARE EARTH

6 x 6	152 x 152	5.1	135677P
8 x 8	203 x 203	7.9	135663P
10 x 6	254 x 152	7.9	135678P
10 x 10	254 x 254	12.3	135664P
12 x 8	305 x 203	12.1	135679P
12 x 12	305 x 305	17.2	135680P
16 x 12	406 x 305	23.1	135682P
14 x 14	356 x 356	23.1	135683P

XTREME RARE EARTH (SANITARY)



Width x Length		Weight lbs	Part No.
in	mm		
6 x 6	152 x 152	5.1	150597P
8 x 8	203 x 203	7.9	150598P
10 x 10	254 x 254	12.3	150599P
12 x 12	305 x 305	17.2	150600P
14 x 14	356 x 356	23.1	150800P

All prices and specifications are subject to change without notice. Terms and conditions of sale are available at www.eriez.com.

ROUND

Round Permanent Magnetic Grate Magnets remove ferrous contamination in hoppers, chutes, floor openings and other areas where free flowing materials are present. These round grate magnets are constructed to fit round processing lines or hoppers. The all-stainless steel unit is installed by simply placing the grate in the hopper with the ends of the magnetic tubes or tie bars resting against the sides.



FEATURES:

- All stainless steel construction
- 1 inch diameter tubes on 2 inch centers
- Sanitary construction (Xtreme Rare Earth only)
- Glass bead surface finish
- 150°F Max Temp (Rare Earth and Xtreme Rare Earth)

CERAMIC

Diameter		Weight lbs	Part No.
in	mm		
6	152	2.8	135685P
8	203	4.0	135694P
10	254	7.1	135692P
12	305	9.0	135696P
14	356	12.6	135699P
16	406	17.4	135701P
18	457	21.6	135703P
20	508	27.6	135705P

RARE EARTH

6	152	3.1	135687P
8	203	5.3	135688P
10	254	8.6	135690P
12	305	11.5	135695P
14	356	15.4	135698P
16	406	22.0	135700P
18	457	27.6	135702P
20	508	35.3	135704P

XTREME RARE EARTH (SANITARY)

Diameter		Weight lbs	Part No.
in	mm		
6	152	3.1	150797P
8	203	5.3	150798P
10	254	8.6	150799P
12	305	11.5	150806P
14	356	15.4	150807P

* Magnets fit inside the specified diameter.

All prices and specifications are subject to change without notice. Terms and conditions of sale are available at www.eriez.com.

Grate-In-Housing

Tramp and fine iron removal in enclosed flow lines or at screen discharges is simplified by Eriez' multi-bank units built into convenient housings. These separators have a slide-bolt door front which makes the magnetic tubes readily accessible for cleaning. Two rows of ceramic or Xtreme Rare Earth tube magnets provide the ultimate protection.

FEATURES:

- Two rows of staggered magnets
- Mild steel housing (Ceramic only)
- Removable door with plastic knobs
- Stainless steel housing and sanitary construction (Xtreme Rare Earth only)
- 150°F Max Temp (Xtreme Rare Earth)
- Dust tight

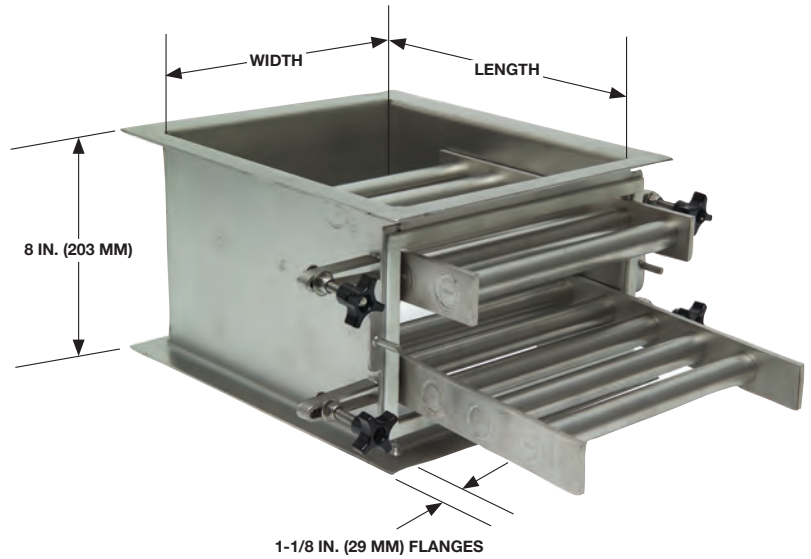

CERAMIC

Width x Length		Weight lbs	Part No.
in	mm		
6-1/8 x 8-1/8	156 x 206	22.5	135723P
8-1/8 x 10-1/8	206 x 257	31.5	135724P
10-1/8 x 12-1/8	257 x 308	40.6	135725P

XTREME RARE EARTH (SANITARY)



Width x Length		Weight lbs	Part No.
in	mm		
6-1/8 x 8-1/8	156 x 206	60.6	150793P
8-1/8 x 10-1/8	206 x 257	77.2	150794P
10-1/8 x 12-1/8	257 x 308	93.7	150795P

All prices and specifications are subject to change without notice. Terms and conditions of sale are available at www.eriez.com.

Easy-to-Clean Grate-In-Housing

The Easy-To-Clean Rare Earth Grate-In-Housing provides quick removal of accumulated fine iron contamination. Simply slide the individual door fronts from the housing and the accumulated metal contamination is scraped from the tube and discharged out the front of the housing. The cleaning cycle is reduced to only a few seconds with this push-pull operation.

FEATURES:

- Two rows of staggered magnets
- 1 inch diameter magnet tubes on 2 inch centers
- Stainless steel tube scrapers
- Metal contaminant discharge chute
- All stainless steel construction
- Glass bead surface finish
- 150°F Max Temp

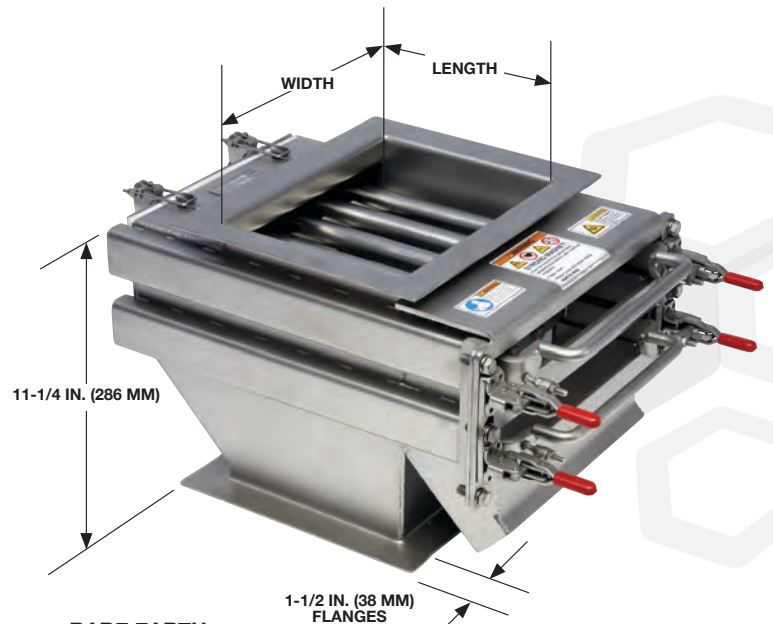

RARE EARTH

Width x Length		Weight lbs	Part No.
in	mm		
8.5 x 6	216 x 152	66.1	135706P
10.5 x 8	267 x 203	88.2	133816P
12.5 x 10	317 x 254	103.6	133828P

All prices and specifications are subject to change without notice. Terms and conditions of sale are available at www.eriez.com.

Easy-to-Clean DSC Grate-In-Housing

MANUAL



AUTOMATED CONVERSION KIT



Eriez' Automated and Manual Easy-to-Clean DSC (Dust-Tight, Sanitary, Convertible) Grate-In-Housings are rugged tramp iron separators. With Eriez' single-skinned tube design, the iron is removed with an A286 stainless steel split ring sandwiched between a pressure plate and backing plate. As both banks cycle, tramp iron is stripped from the tubes outside the product zone. The tramp metal is then discharged through a small chute at the front of the housing. The traditional cleaning cycle is reduced to a simple push-pull operation.

Depending on the application, some customers find their process has excessive tramp iron or the Grate-In-Housing is installed in a difficult to access location requiring an upgrade to a self-cleaning model.

The DSC's convertible design allows customers to purchase a Conversion Kit and use hand tools to make the unit an automatic cleaner. The kit requires no cutting or welding, and includes a NEMA 12 push-button control panel with air prep and regulation.

FEATURES:

- RE7 Xtreme Rare Earth only
- Dust-Tight construction
- Sanitary housing
- Convertible Manual ETC can be upgraded to Auto ETC
- Catch pan discharge
- Blank flanges
- All 304 Stainless Steel construction
- 12.25 inch overall height
- 150° Max Temp



MANUAL

Width x Length		Weight	Part No.
in	mm		
8.5 x 6	216 x 152	109/49	165518
10.5 x 8	267 x 203	137/62	165515
12.5 x 10	318 x 254	165/75	165517

CONVERSION KIT ONLY

Automated Conversion Kit	Part No.
8.5 x 6	201703299G4
10.5 x 8	201703299G6
12.5 x 10	201703299G8

All prices and specifications are subject to change without notice. Terms and conditions of sale are available at www.eriez.com.

Rare Earth Drawer Magnet Assemblies

MODEL PM MAGNETS

Eriez' Model PM Rare Earth Drawer Magnet assembly will improve your profitability by preventing costly product defects, plugged value gates and hot runner tips, machine damage and downtime. These powerful Rare Earth Grates simply slide into most existing drawer magnet housings, immediately improving separation performance and your bottom line. Four sizes are available and they can be used with mild steel housings.

FEATURES:

- Designed to fit competitor housings
- 316L Stainless Steel PM Rare Earth magnets are up to 3x stronger than other RE magnets and up to 50x stronger than many ceramic magnets
- Clear drawer front for visual inspection of magnets
- Close tube spacing for superior tramp metal recovery (1.75 inch centerlines)
- Ability to capture and hold fine and weakly magnetic particles
- Magnets handle resin temperature up to 150°F and 250°F
- Adhesive backed gaskets included for customer installation on the door or housing
- Compatible with mild steel housing due to our unique guide rail design
- Slots are 1/2 inch wide by 1-1/16 inch overall length

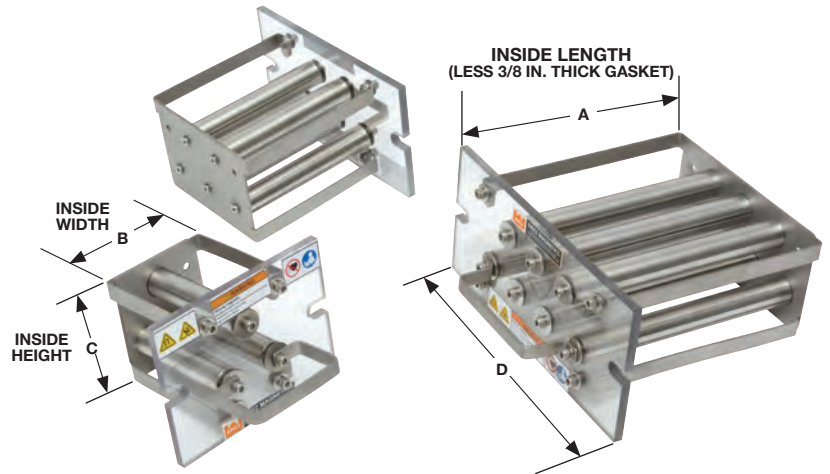

RARE EARTH DRAWER MAGNETS (INCHES)

Normal Housing Size	Qty Mag. Tubes	A	B	C	D	Wt. lbs	150°F Part No.	250°F Part No.
4 x 4	3	4-3/16	3-13/16	3-7/8	6-1/2	7.0	138938P	138936P
6 x 6	5	6-3/16	5-13/16	3-7/8	8-1/2	12.0	138943P	138941P
8 x 8	7	8-3/16	7-13/16	3-7/8	10-1/2	15.0	138947P	138946P
10 x 10	9	10-3/16	9-13/16	3-7/8	12-1/2	22.0	138953P	138951P

RARE EARTH DRAWER MAGNETS (MM)

Normal Housing Size	Qty Mag. Tubes	A	B	C	D	Wt. lbs	150°F Part No.	250°F Part No.
102 x 102	3	106	97	98	165	3.18	138938P	138936P
153 x 153	5	157	148	98	216	5.44	138943P	138641P
203 x 203	7	208	198	98	267	6.80	138947P	138946P
254 x 254	9	259	249	98	318	10.0	138953P	138951P

All prices and specifications are subject to change without notice. Terms and conditions of sale are available at www.eriez.com.

Complete PM Grate-In-Housings

ALSO AVAILABLE



Pneumatic Magnets

RF CARTRIDGE

Eriez' "RF" (Radial Field) Cartridge Magnet is ideal for removing tramp iron from dry, free-flowing food or chemical products conveyed in pneumatic pipelines.

Material enters the housing, is distributed by a solid stainless steel cone and passes in close proximity to the magnetic cartridge.

Ferrous contamination is attracted and held by the magnet while the separated product continues past the magnet and out of the housing. The ferrous contamination remains on the magnet until the cartridge is removed and cleaned.

FEATURES:

- High-strength permanent tapered-step magnetic elements
- Stainless steel housing construction
- Removable magnet element with built-in handles for easy cleaning
- Utilizes typical pneumatic conveyor couplings for easy operation and positive seal
- Independent magnet element for easy handling
- Standard units available for up to 25 psig (1.7 bar) operation and -10 psi vacuum
- Tube O.D. ends
- For horizontal or vertical-up use only

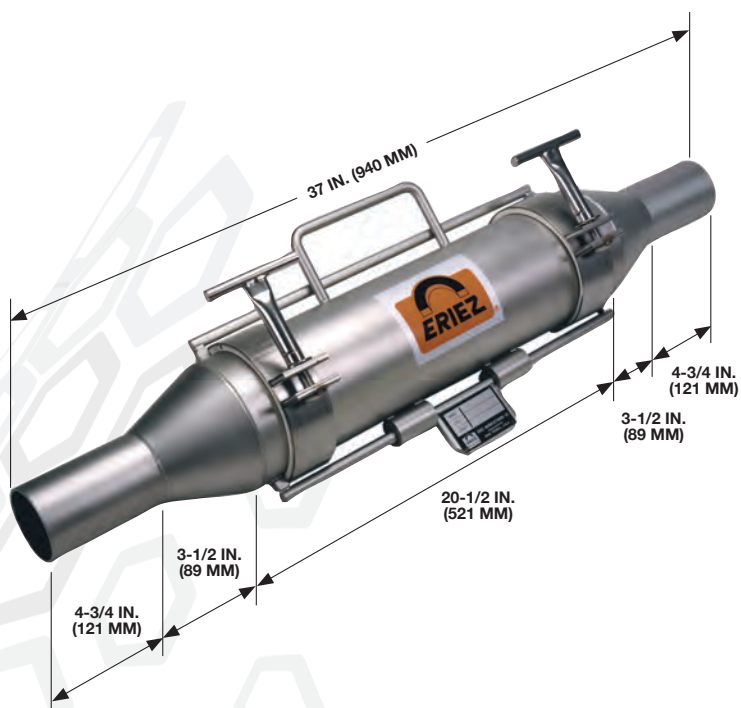

RARE EARTH

A (Inlet OD)		B (Housing OD)		Weight		Part No.
in	mm	in	mm	lbs	Kg	
4	102	5-9/16	141	95	43.2	131700
5	127	6-5/8	168	110	50	131690

All prices and specifications are subject to change without notice. Terms and conditions of sale are available at www.eriez.com.

Ferrous Traps

MODEL B

These powerful permanent magnetic traps provide protection for liquid lines and sensitive processing equipment such as pumps. They preserve product purity by removing small particles of magnetic scale, rust and fine iron contamination.

The magnetic element, consisting of a group of magnetic tubes, is arranged to cause the material flow entering the body to impinge against the tubes and filter through the magnetic field, completely covering the open area. This arrangement takes advantage of the material change in direction and the difference in inertia between the unwanted iron and the material carrying it. Entrapped iron will have a tendency to work around and cling to the downstream side of the tubes. This action prevents iron particles from being washed off by the flow of material.

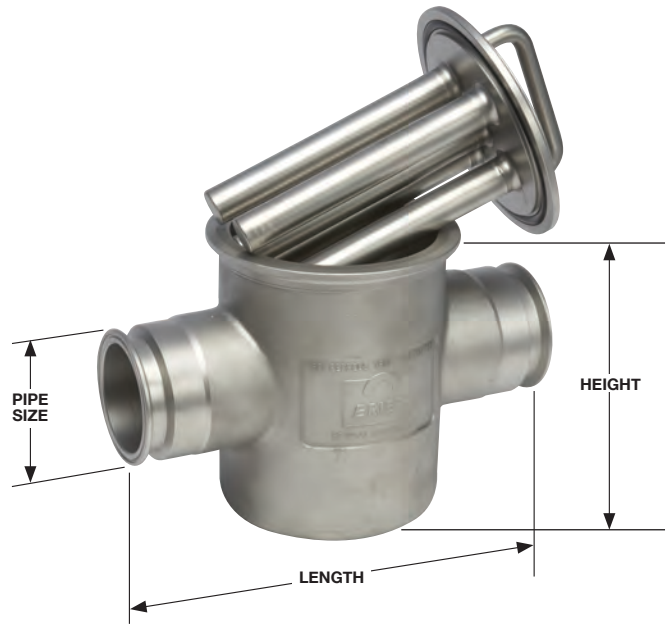

FEATURES:

- All 316 stainless steel construction
- Cast body
- Pressure up to 150 psi
- Glass bead surface finish
- Ferrule (14 WLMO) units feature sanitary construction
- For product and CIP temperatures up to 250°F



XTREME RARE EARTH

Pipe Size		Length		Height		Sanit. Design	Ports	Wt. lbs	Part No.
in	mm	in	mm	in	mm				
2	51	11	279	7-1/16	179	No	NPT	22.0	201508770G1
2	51	11	279	7-1/16	179	Yes	Ferrule	22.0	201508773G1
3	76	12	305	9-7/8	251	No	NPT	35.3	201508776G1
3	76	12	305	9-7/8	251	Yes	Ferrule	35.3	201508779G1
4	102	15	381	10-5/8	270	No	NPT	37.5	201508782G1
4	102	15	381	10-5/8	270	Yes	Ferrule	37.5	201508785G1

All prices and specifications are subject to change without notice. Terms and conditions of sale are available at www.eriez.com.

CRITICAL SPARES

Spares	B2	B3	B4
	Part No.	Part No.	Part No.
Xtreme Rare Earth Element	150583	150589	150595
Sanitary Xtreme Rare Earth Element	150580	150586	150592
Clamp	472834	472835	472836
Buna Gasket	226315	226322	226316

MODEL U

The Model U Trap utilizes a Rare Earth magnet circuit to remove fine and weakly magnetic contamination like rust, scale, or screen wire. Model U Traps remove ferrous contamination from difficult-to-flow or chunky products like vegetables, salsa, or meat batters.

The special body design of the Model U incorporates a gradually tapered transition that gently directs the product over a smooth magnetic surface. The body design does not incorporate diverters or baffles.

This design works well for applications where finger-style traps would plug due to large product size or where delicate products would break if forced against a baffle.

The Model U Trap with its compact design can be installed easily into 3 or 4-inch (76 or 102 mm) lines. The standard unit is sanitary, incorporates our Super-Strength Rare Earth magnet element, a 304 stainless steel body and 14WLMO Ferrule Ends.



Line Size		A	B	C	D	Weight
3	in	14-3/8	5-7/8	3	10	33 lbs
76	mm	365	149	76	254	15 kg
4	in	14-3/8	7	4	10	40 lbs
102	mm	365	178	102	254	18 kg

Design ≤ 50 psi Magnetic elements are rated for 250°F

Part No.	Description
146960	Eriez Model U-3 Magnetic Trap 304 SS Body with 3" 14WLMO Inlet and Outlet Xtreme Rare Earth Plate Magnet with 400SS Step
146961	Eriez Model U-4 Magnetic Trap 304 SS Body with 4" 14WLMO Inlet and Outlet Xtreme Rare Earth Plate Magnet with 400SS Step

MODEL L

This Ferrous Trap model has been designed to serve as an effective, low-cost, magnetic pipeline trap where operating conditions are not severe. This unit is cast stainless steel construction capable of withstanding pressures up to 150 psi (10.5 kg/sq cm). It is built for 2 inch (51 mm) pipelines; standard reducers can be used to adapt it to lines as small as 1/2 inch (13 mm).

FEATURES:

- 2 inch NPT Ports
- Cast stainless steel
- Single tube magnetic element
- Pressure up to 150 psi
- 150°F Max Temp (Rare Earth)

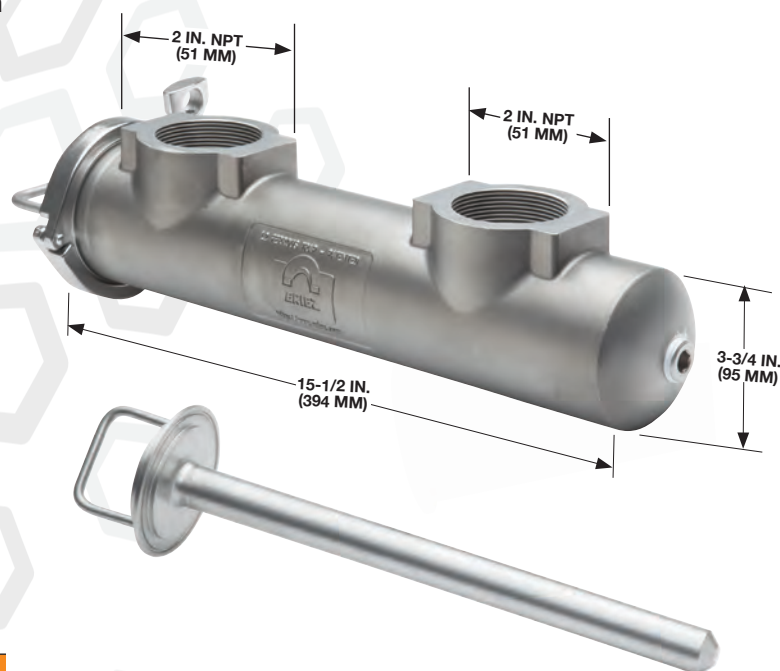

CERAMIC

Size		Weight	Part No.
in	mm	lbs	
2	51	17.0	201507127G2

RARE EARTH

2	51	17.0	201507127G1
---	----	------	-------------

All prices and specifications are subject to change without notice. Terms and conditions of sale are available at www.eriez.com.

CRITICAL SPARE PARTS KITS (L TRAP ONLY)

Spares	Part No.
Ceramic Tube	201508264G1
Rare Earth Tube	201510428G1
O-Ring	440031

Plate Magnets

Eriez Permanent Plate Magnets are the workhorses of magnetic separation and provide dependable and economical solutions to problems associated with tramp iron contamination in processing lines. Plate Magnets installed in chutes, spouts, ducts, pipes or suspended over conveyors remove tramp iron to help prevent costly shutdowns associated with machinery damage, prevent spark-caused fires and explosions, prevent product contamination and improve product purity.

FEATURES:

- All stainless steel construction
- Smooth face with hinges (Ceramic magnets)
- Glass bead surface finish
- Milled 400 SS step face with hinges (Rare Earth+ and Xtreme Rare Earth+)
- Sanitary finish (Rare Earth+ and Xtreme Rare Earth+)
- 150°F Max Temp (Rare Earth+ and Xtreme Rare Earth+)

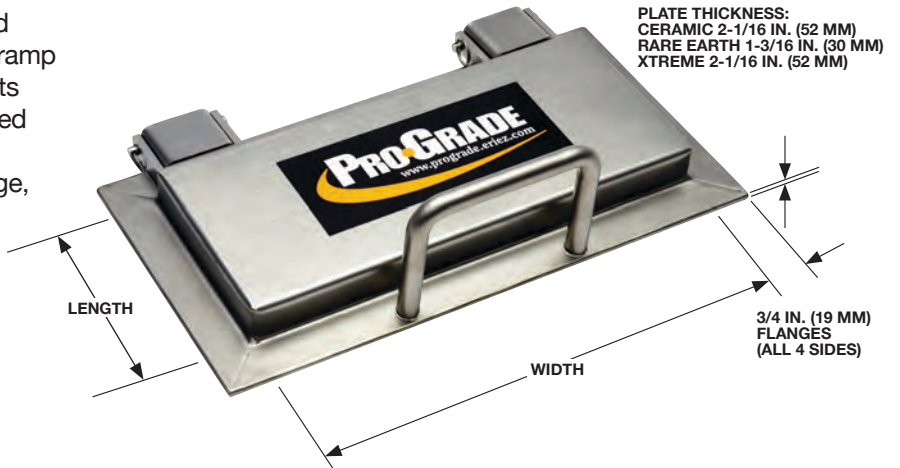

CERAMIC

Width		Length		Weight	Part No.
in	mm	in	mm	lbs	
6	152	7-5/8	194	17.2	135711P
8	203	7-5/8	194	23.8	135667P
10	254	7-5/8	194	30.4	135712P
12	305	7-5/8	194	37.0	135668P
16	406	7-5/8	194	50.3	135713P
20	508	7-5/8	194	63.5	135714P
24	610	7-5/8	194	76.7	135715P

MAXIPOWER PLATE

8	203	10.63	270	48	130108E
10	254	10.63	270	65	130110P
12	304	10.63	270	75	130112P
14	356	10.63	270	84	130114P

RARE EARTH+ (SANITARY)

6	152	5-1/2	140	12.3	129906P
8	203	5-1/2	140	17.2	129908P
10	254	5-1/2	140	22.0	129910P
12	305	5-1/2	140	26.9	129912P
14	356	5-1/2	140	31.7	129914P
18	458	5-1/2	140	40.8	129918P
24	610	5-1/2	140	54.3	129924P

Maxi Power Plate

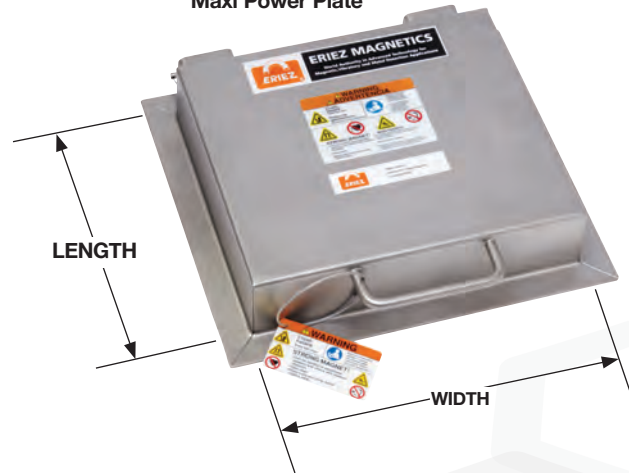

XTREME RARE EARTH+ (SANITARY)

Width		Length		Weight	Part No.
in	mm	in	mm	lbs	
6	152	5-1/2	140	18.1	135283P
8	203	5-1/2	140	24.7	135285P
10	254	5-1/2	140	31.3	135287P
12	305	5-1/2	140	37.9	135289P
14	356	5-1/2	140	44.5	135291P
18	458	5-1/2	140	57	135295P
24	610	5-1/2	140	74	135299P

All prices and specifications are subject to change without notice. Terms and conditions of sale are available at www.eriez.com.

RE7 Xtreme Rare Earth Inspection Tubes

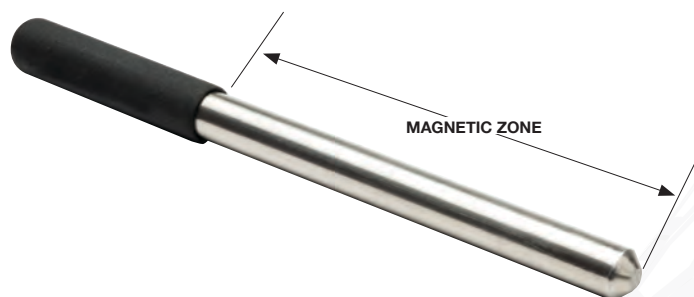

Perfect for quality checks at any stage of a process. The industry's most powerful tube magnet in three lengths with a rubber grip handle and dead zone making it easier to wipe off.

FEATURES:

- Varied lengths for different applications
- 150° Max Temp



Dimensions		Part No.
OAL 15"	10" Long Magnetic Zone	201703403G1
OAL 20"	15" Long Magnetic Zone	201703775G1
OAL 25"	20" Long Magnetic Zone	201703784G1

Handheld Inspection Magnet

Handheld inspection magnet for checking the quality of a product or removing loose tramp iron from a flow of materials.

FEATURES:

- Strong Rare Earth Magnets
- Deep-reach magnetic field
- All 304 stainless steel contact
- Avoid material rejections



Dimensions (in inches)			Weight	Part No.
A	B	C/D		
5 OAH	2.75	2.25	2 lbs.	201412918G1

Pull Test Kits



DIGITAL AND ANALOG KITS

Eriez offers two different Pull Test Kit options, one with a mechanical scale and one with a digital scale with traceable calibration certification.

The kit with a digital scale is recommended for customers in the food or pharmaceutical industries that require calibrated scale certification for auditing purposes. The digital scale is also available separately.

FEATURES:

- Measures your magnet's consistency in performance over time
- Variety of test pieces and spacers or different magnet styles (kit only)
- Digital Scale and Digital Scale Kit is NIST Certifiable by your local scale company
- Part of your Quality Assurance or HACCP Programs
- Convenient carrying case

Type	Certified	Weight		Part No.
		lbs	Kg	
Manual Scale Kit	No	8.0	3.6	107121E
Digital Scale Kit	Yes	10.0	4.5	201512425G2
Digital Scale Only	Yes	5.0	2.3	470697

All prices and specifications are subject to change without notice. Terms and conditions of sale are available at www.eriez.com.

- STANDARD KIT with mechanical scale
- DIGITAL CALIBRATED KIT includes traceable digital scale

ERIEZ

Suspended Electromagnets

Eriez Suspended Electromagnets are designed to reach into a burden of material on a conveyor belt to remove large unwanted tramp metal that can damage downstream equipment. They are the global standard for rugged, dependable suspended electromagnets.

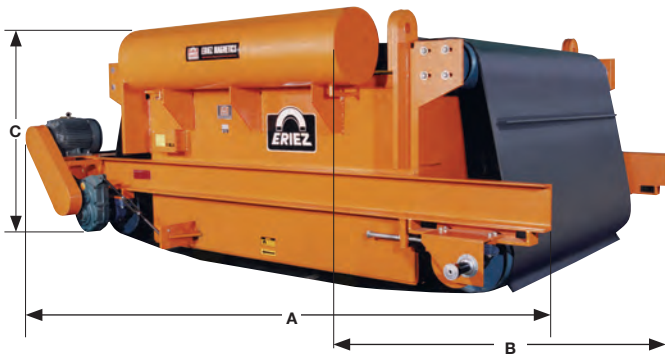

SELF CLEANING

FEATURES:

- Convertible design allows cross-belt or head pulley positioning
- Exclusive oil expansion tank prevents condensation and protects against hot spots to extend coil life
- Five-year coil warranty
- Adjustable oil expansion tank design is mounted with slotted brackets for any installation angle, allowing the user to rotate the tank so the moisture drain is always on the low side
- CSA Approved

MANUAL CLEAN

FEATURES:

- Exclusive oil expansion tank prevents condensation and protects against hot spots to extend coil life
- Five-year coil warranty
- Aluminum coils use Nomex insulation and fiberglass spacers to prevent shorts
- Adjustable oil expansion tank design is mounted with slotted brackets for any installation angle, allowing the user to rotate the tank so the moisture drain is always on the low side
- CSA Approved
- EriezXpress units include an adjustable cable sling for single-point suspension

STOCK REQUIRES ASSEMBLY

Item	DC Volt.	Dimensions (in.)			Mag Box Size	WT lbs	*Belt Width	Susp. Height	Control	Part No.
		A	B	C						
SE-7328/7318	115	87-1/4	63-5/16	33-3/4	42"x42"	4,197	42"	11"	50C	163104
SE-7525/7515	115	99-1/4	78-3/8	39-1/4	54"x54"	7,448	54"	13"	10K	150687
SE-7625/7615	115	105-1/4	84-5/8	41-5/16	60"x60"	9,736	60"	15"	10K	150694

* Maximum conveyor belt width that magnet can be suspended over.
 ** Call Eriez for tariff adjusted prices.



Item	Box Dimensions (in.)			Weight		Control	Part No.
	A	B	C	lbs	Kg		
SE-7338	42	42	22	3,035	1,376	50C	136992E
SE-7535	54	54	25	5,800	2,631	10K	137000E

** Call Eriez for tariff adjusted prices.

10-DAY ASSEMBLY

7635	60	60	27	9,020	4,091	10K	N/A
7735	66	66	31	12,420	5,633	12.5K	N/A
7835	72	72	35	16,950	7,688	15K	N/A
7935	78	78	39	23,300	10,568	20K	N/A

All prices and specifications are subject to change without notice. Terms and conditions of sale are available at www.eriez.com.

Rectifier Controls



Item	Dimensions (in inches)			Watts	CSA Approved	Input Power (AC)	Output Power (DC)	Part No.	
	A	B	C						
50C41	14	30	38	5,000	No	460/60/3	115	140850E	X
75C41	18	36	48	7,500	No	460/60/3	115	134311E	X
10K41	18	36	48	10,000	No	460/60/3	115	134312E	X
12.5K41	18	36	61	12,500	No	460/60/3	115	136963E	X
15K42	18	36	61	15,000	No	460/60/3	230	136037E	X
20K42	27	38	74	20,000	No	460/60/3	230	136961E	X
5 KW	17	36	60	5,000	Yes	575/60/3	115	448448	
10 KW	17	36	72	10,000	Yes	575/60/3	115	448438	
20 KW	17	36	72	20,000	Yes	575/60/3	230	449594	

All controls have NEMA 4 enclosure

All prices and specifications are subject to change without notice. Terms and conditions of sale are available at www.eriez.com.

Suspended Permanent Magnets

Suspended Magnetic Separators are designed for applications where ferrous contaminants are to be removed from bulk products – either on a moving conveyor belt or chute.

FEATURES:

- Low operating cost
- Powerful magnetic field
- Permanent magnet requires no power
- Recommended heights of 12 inches or less
- Uninterrupted magnetic protection
- Manual clean magnets include drawer type stripper and cable sling suspension
- Simple installation
- 230V/480V input for drive

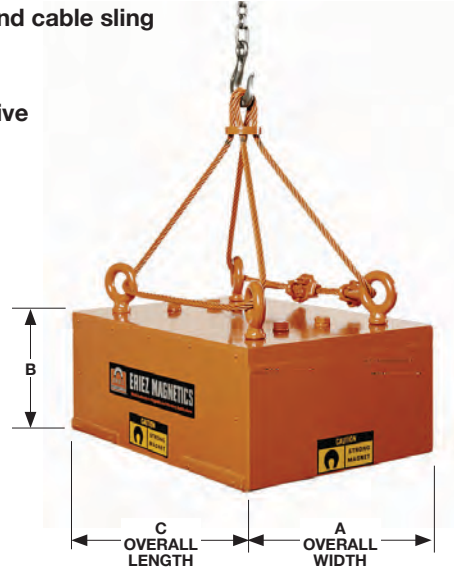
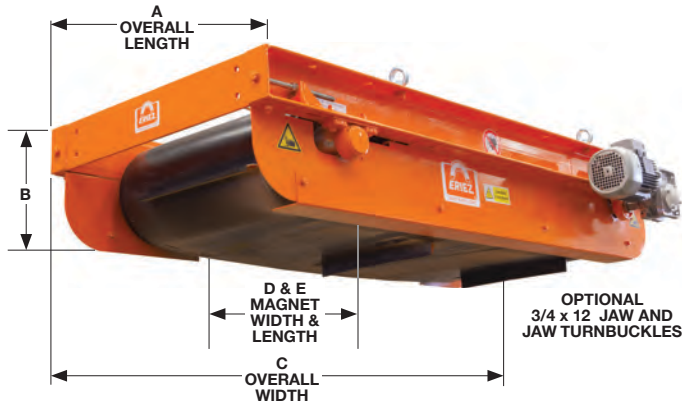

CP 20 MODELS

The CP 20 Series Permanent Magnets provide a continuous and uniform magnetic field across the feed belt to remove damaging tramp iron.

TP 25 MODELS

The TP 25 Series Magnets utilize a powerful twin pole magnetic circuit to provide maximum ferrous removal at higher suspension heights.

SELF-CLEANING Turnbuckle suspension required, see below.

Item	Dimensions (in inches)					Weight		Part No.
	A	B	C	D	E	lbs	Kg	
CP 20/80 (Electric)	48	16	85	33	21	1,984	900	468337E (Electric)
CP 20/80 (Hydraulic)	54	16	85	33	21			476836 (Hydraulic)
CP 20/100 (Electric)	48	16	85	41	21	2,315	1,050	468690 (Electric)
CP 20/100 (Hydraulic)	54	16	85	41	21			474666 (Hydraulic)
CP 20/120 (Electric)	48	16	95	50	21	2,646	1,200	468691 (Electric)
CP 20/120 (Hydraulic)	54	16	95	50	21			476839 (Hydraulic)
3/4" x 12 Jaw Turnbuckles	NA					8/each	3.6/each	239037

SELF-CLEANING Turnbuckle suspension required, see below.

Item	Dimensions (in inches)					Weight		Part No.
	A	B	C	D	E	lbs	Kg	
TP 25/80 (Electric)	50	20	83	33	29	3,597	1,635	476841 (Electric)
TP 25/80 (Hydraulic)	56	20	83	33	29			476842 (Hydraulic)
TP 25/100 (Electric)	50	20	92	43	29	4,312	1,960	476844 (Electric)
TP 25/100 (Hydraulic)	56	20	92	43	29			476845 (Hydraulic)
TP 25/120 (Electric)	50	20	99	50	29	5,016	2,280	476847 (Electric)
TP 25/120 (Hydraulic)	56	20	99	50	29			474856 (Hydraulic)
3/4" x 12 Jaw Turnbuckles	NA					8/each	3.6/each	239037

MANUAL-CLEANING

CP 20/80	33	10	21	—	—	1,100	500	476837
CP 20/100	41	10	21	—	—	1,434	652	476838
CP 20/120	50	10	21	—	—	1,767	803	476840

MANUAL-CLEANING

TP 25/80	33	14	29	—	—	2,640	1,200	476843
TP 25/100	43	14	29	—	—	3,216	1,462	476846
TP 25/120	50	14	29	—	—	3,793	1,724	476848

All prices and specifications are subject to change without notice. Terms and conditions of sale are available at www.eriez.com.

Other Magnetic Separators

Eriez offers many types of magnetic separators not featured in this catalog of Quick Ship equipment. Below are a few special order models.



DRUM-IN-HOUSING SEPARATOR

Drum magnets are designed to separate a higher volume ferrous material. By design, they are continuously self-cleaning and extremely durable.

- Continuous self-cleaning operation for optimum separation efficiency
- Numerous magnetic circuits including Criss-Cross, Agitation, and numerous Rare Earth designs for every separation requirement
- Adjustable splitter to fine-tune separation performance
- Ideal for high-volume 24/7 ferrous removal



ROTA-GRATE® IN-HOUSING REMOVABLE TUBE ASSEMBLY

Same design as the Rota-Grate In-Housing, with removable tube magnet assemblies. This greatly speeds cleaning during operation.

- Individual Tube Magnets can be removed one-by-one for easy cleaning
- Low profile housing design
- SEW Euro drive motor permits rotating of reel by hand to aid in the cleaning process
- Swing-bolt, hinged door with “T”-handles for easy access



AUTO DEEP REACH MAGNETIC SEPARATOR

Eriez Deep Reach Magnetic Separator removes tramp iron from heavy flows that normally bridge or choke grate magnets. Two powerful magnet circuits surround a chute to penetrate product flows like cocoa, powdered cheese, brown sugar, starch, flour, gypsum and other sticky products to remove ferrous contamination.

- Automated stripper periodically removes accumulated tramp iron
- Stainless steel housing with safety guard for moving parts
- Rare Earth or ceramic magnetic circuits
- Push-button operation



RARE EARTH ROLL

Eriez Rare Earth Roll high-intensity magnetic separators provide maximum efficiency in the separation of weakly magnetic particles in product purification applications for fine granular materials.

- Powerful Rare Earth Roll Magnet produces in excess of 20,000 surface gauss for unsurpassed separation efficiency
- High-strength Kevlar belt for continuous self-cleaning operation
- Includes vibratory feeders to meter material for consistent separation performance
- Graduated and adjustable splitter to fine-tune separation efficiency



Eriez Quick Ship program is designed to stock Metal Detectors for quick assembly and delivery.

X8 Metal Detector

Metal Detectors

X8 Construction

Light Dome

Robust, low-profile, multi-colored dome light provides multiple levels of visual and audible alerts based on the user-defined settings.

Thick Polymer Aperture

The specially designed and machined thick polymer liner seals the internal coils, making the aperture head impenetrable during high-pressure wash down.

High-Pressure Wash Down Guard

Furnished with a PETG shield that is durable, scratch resistant, and protects the touch screen from physical damage and direct impact.

Easy Setup

Software provides automatic product setup with self-checking capabilities and calibration verification for simple start-up and operation.

Data Access

Safe, protected access to a range of data ports provides remote communication transfers via Ethernet and USB.

Food-Grade Belt

Plastic chain, food-grade belts are easily removed and ideal for packaged foods.

Stainless Steel Sanitary Construction

The system is constructed from 304 stainless steel making it extremely durable.

X8 Metal Detectors

Eriez' feature-rich, dual frequency X8 Metal Detector is designed to achieve the highest levels of sensitivity to detect small ferrous, non-ferrous and stainless steel metal contaminants.

The X8 Metal Detector offers a 4-inch easy-to-use capacitive touch screen interface, multiple pre-programmed languages, easy set-up and reporting, USB and interface ports, remote access and the standard high-pressure wash down design.

FEATURES:

- **Stainless Steel Construction**
- **Tool-less Disassembly**
- **Compact Footprint**
- **Variable Speed Belt**
- **Adjustable Belt Height**

X8 Metal Detector

X8 Metal Detectors



X8 METAL DETECTOR CONVEYOR SYSTEMS

QUICK SHIP

Size	Aperture Opening	Conveyor Systems
6" W CONVEYOR BELT	8W X 4H	W/6X60 CONVEYOR
	8W X 6H	W/6X60 CONVEYOR
	8W X 8H	W/6X60 CONVEYOR
	8W X 10H	W/6X60 CONVEYOR
	8W X 12H	W/6X60 CONVEYOR
12" W CONVEYOR BELT	14W X 6H	W/12X60 CONVEYOR
	14W X 8H	W/12X60 CONVEYOR
	14W X 10H	W/12X60 CONVEYOR
	14W X 12H	W/12X60 CONVEYOR
	14W X 14H	W/12X60 CONVEYOR

Size	Aperture Opening	Conveyor Systems
18" W CONVEYOR BELT	20W X 6H	W/18X72 CONVEYOR
	20W X 8H	W/18X72 CONVEYOR
	20W X 10H	W/18X72 CONVEYOR
	20W X 12H	W/18X72 CONVEYOR
	20W X 14H	W/18X72 CONVEYOR
	20W X 16H	W/18X72 CONVEYOR
	20W X 18H	W/18X72 CONVEYOR
	20W X 20H	W/18X72 CONVEYOR
24" W CONVEYOR BELT	26W X 6H	W/24X84 CONVEYOR
	26W X 8H	W/24X84 CONVEYOR
	26W X 10H	W/24X84 CONVEYOR
	26W X 12H	W/24X84 CONVEYOR
	26W X 14H	W/24X84 CONVEYOR
	26W X 16H	W/24X84 CONVEYOR
	26W X 18H	W/24X84 CONVEYOR
	26W X 20H	W/24X84 CONVEYOR

**Need it Faster?
Ask About Our**

**QUICK SHIP 2-DAY
PROGRAM**

All prices and specifications are subject to change without notice. Terms and conditions of sale are available at www.eriez.com.

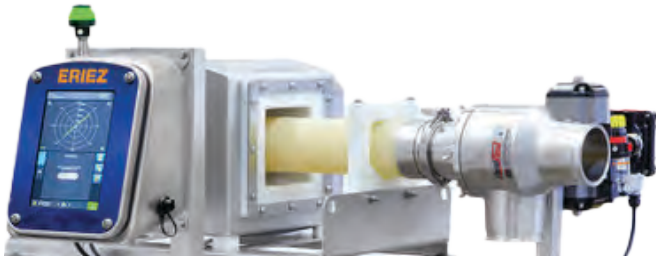

X8 LIQUID LINE METAL DETECTORS WITH DOME LIGHT

Eriez Liquid Line System enhances product purity and protects vital downstream equipment from metal in the product stream.

The X8 Liquid Line Metal Detectors are used for viscous products such as liquids, slurries, syrups, pastes and many other pumped products. When metal is detected in the product flow, a reject signal is channeled to one of the available output relays. The output relay can be used to activate a ball valve, control a visual or audio alarm, or send a signal to a PLC.

QUICK SHIP

Model	Pipe Size	Aperture Opening
X8LL	2"	3.5" x 3.5"
X8LL	3"	4.5" x 4.5"



X8 VERTICAL LOW PROFILE SYSTEMS WITH DOME LIGHT

Eriez X8 Vertical Low Profile Systems are for use in gravity free-fall applications. They are constructed of 304 stainless steel and include an X8 detector with remotely housed electronics, support plate and diverter valve.

QUICK SHIP

Model	Pipe Size	Aperture Opening
X8VS	4"	5.5
X8VS	6"	7.5
X8VS	8"	9.5

All prices and specifications are subject to change without notice. Terms and conditions of sale are available at www.eriez.com.

HANDHELD DETECTOR

FEATURES:

- Ideal for handheld use with shallow layers of material
- Power requirements are 110V, 60Hz



Dimensions (in inches)			Weight	Part No.
A	B	C/D		
5 OAH	2.75	2.25	2 lbs.	133365E

All prices and specifications are subject to change without notice. Terms and conditions of sale are available at www.eriez.com.

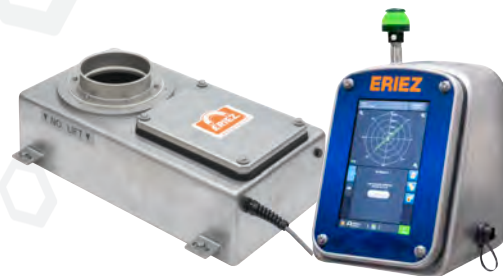

VERTICAL FORM FILL AND SEAL WITH DOME LIGHT

QUICK SHIP

Diameter	Specifications
3"	25 ft Remote Control, SS
4"	25 ft Remote Control, SS
6"	25 ft Remote Control, SS
8"	25 ft Remote Control, SS
10"	25 ft Remote Control, SS



Feeders Fast offers nearly 40 feeder models using stock components, available for shipment within five days. These quick-ship, electromagnetic vibratory feeders are AC powered making them extremely reliable and energy efficient – ideal for many sanitary, industrial and process applications. Compact feeders up to 20 TPH are available in tray sizes to 16 inches wide and 60 inches long. Heavy-Duty feeders now available in 4 models with capacities from 70 to 270 TPH.

**FEEDERS
FAST** 

Vibratory Equipment

Vibratory Feeders

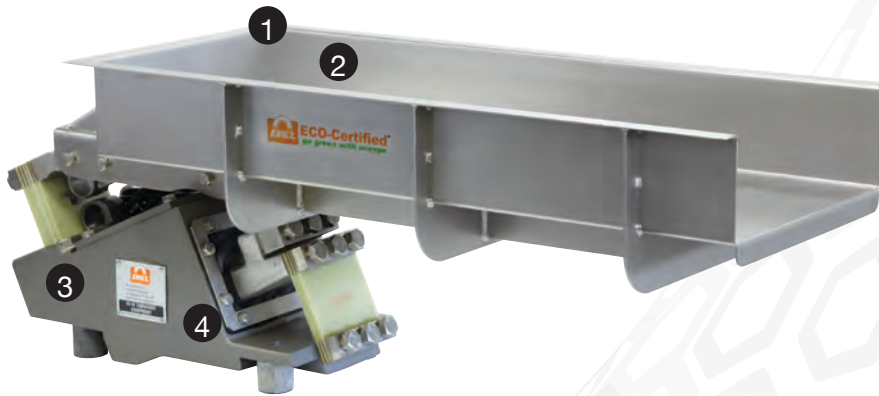

- 1 304 stainless steel, continuously welded tray interior
- 2 Glass beaded finish
- 3 Steel-It epoxy paint
- 4 AC electromagnetic drive

RELIABLE & EFFICIENT

- Low maintenance - no rotating parts, no lubrication
- Energy efficient
- Virtually silent operation

FLEXIBLE

- Accurately feeds most products - models are designed to feed damp, light, dense, heavy, fluffy, sticky, leafy and most difficult to move products
- Fits all applications - from packaging, batching, metering and more

VERSATILE

- Easily integrated into feed systems
- Clean construction
- Drives - 115 Volt / 60 hz / 1-phase operation; HD drive 115/30
- Drive painted with Steel-It epoxy, FDA approved
- CE and CSA approved models available

SOLID-STATE CONTROLS

- Compact NEMA 12 type, IP54 enclosures ideal for automation
- Accepts analog signals (4-20 MA or 0-10 VDC)
- Remote on/off

ELECTROMAGNETIC DRIVE

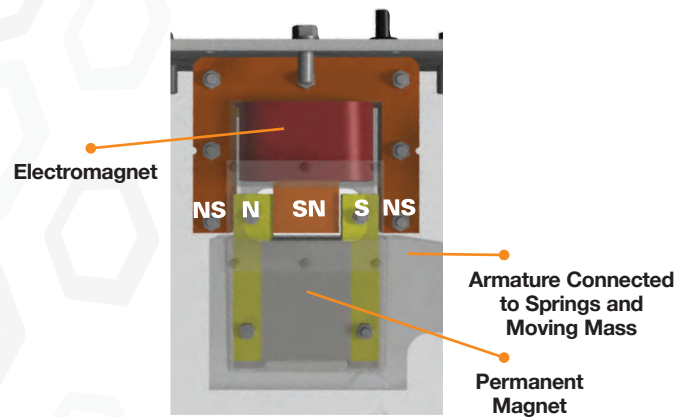

Drive Operation

The poles of the permanent magnet are shown intermeshed in the air gaps of the AC electromagnet. The polarity of the permanent magnet is fixed, while the polarity of the electromagnet alternates, creating the vibratory motion. The electromagnet polarity is shown as it exists on one side of the AC sine wave.

When energized, both poles of the permanent magnet are attracted toward the unlike electromagnet poles while being repelled in the same direction by the like poles. This creates four forces acting together to drive the armature and moving mass in the same direction.

On the opposite side of the sine wave, the polarities of the electromagnet are reversed; the armature is driven in the opposite direction completing the vibratory cycle.

Amplitude Control

These drives offer 100% variable feed rate control. The amplitude of the vibration is directly controlled by the amount of AC voltage applied to the electromagnet. Simple variation of the AC voltage results in similar amplitude variation from zero to maximum.

Electromagnetic Compact Feeders



MODEL A FEEDERS

The smallest feeder in the line, this model will give precise feeding of the most minute amounts of materials. It is ideal for feeding a regulated amount of granular to small lump material from a hopper to a second process, in small packaging operations or laboratory use.



MODEL C FEEDERS

Larger than Model A Feeders, these units use the same patented drive that provides the best linearity in the industry. Special construction is also available for Class II, Group F and G installation.

FEEDERS FAST 5-DAY ASSEMBLY

Model	Tray Type	Control	Tray Width		Tray Length		Capacity*		Part No.
			in	mm	in	mm	tons/hr	m tons/hr	
15A	Medium Flat	A	4	102	20	508	3	1.8	133591E
15A	Wide Flat	A	7	178	14	356	3.6	3.3	10206120

* Capacities are based on dry sand weighing 100 lb/cu ft.

FEEDERS FAST 5-DAY ASSEMBLY

Model	Tray Type	Control	Tray Width		Tray Length		Capacity*		Part No.
			in	mm	in	mm	tons/hr	m tons/hr	
26C	Medium Flat	A	5	127	22	559	4	3.6	13148620
26C	Wide Flat	A	7	178	20	508	5.6	5	13148621
36C	Narrow Flat	B	6	152	36	914	5.2	4.8	13178520
36C	Medium Flat	B	8	203	30	762	7	6.4	13178521
36C	Wide Flat	B	10	254	24	610	8.75	7.9	133593E
46C	Wide Flat	B	12	305	30	762	15	13.6	13090020
46C	Wide Flat	B	14	356	24	610	18	16	13090021
46C	Narrow Flat	B	10	254	38	965	17.5	11.4	13090022
46C	Medium Flat	B	14	356	30	762	18	16	13090023
56C	Narrow Flat	C	12	305	42	1067	17	15.6	13040522
66C	Medium Flat	C	14	356	60	1524	25	22.7	13120022
66C	Wide Flat	C	16	406	48	1219	28.6	26	13120020
76C	Narrow Flat	C	18	457	96	2438	40	36	201902738G1

* Capacities are based on dry sand weighing 100 lb/cu ft.

All prices and specifications are subject to change without notice. Terms and conditions of sale are available at www.eriez.com.

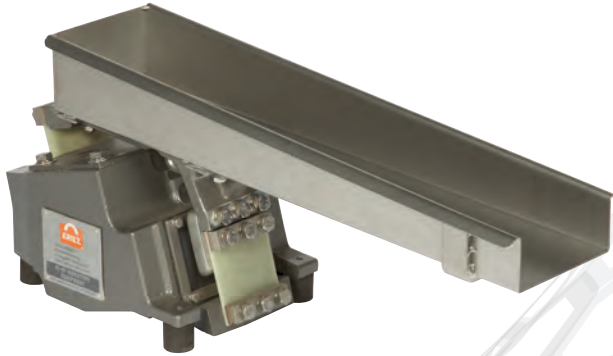

MODEL HS FEEDERS

Eriez AC operated Hi-Speed (HS) Feeders have been designed for exceptionally high speed feeding of light, bulky materials. They provide greater economy and efficiency in feeding, filling, etc., and are ideal for use in conjunction with many weigh scale and packaging machines.

These feeders operate at speeds up to 75% greater than standard models; however, they do follow many of the basic tried and proven mechanical design and construction features of other Hi-Vi Feeders.

The units are light and functional and can be installed easily in a minimum of space in conjunction with other equipment.



MODEL HD FEEDERS

High Deflection (HD) Vibratory Feeders combine the higher deflection 3/16 inch (4.8 mm) and lower frequency (30 cps) advantages of a mechanical feeder with the trouble-free service of an electromagnetic feeder.

The Model HD is designed to handle powders and leafy products that normally could not be fed successfully in an electromagnetic feeder. Feed rates of up to 80 feet per minute (24 m/min) are possible for products with a bulk density less than 10 lb/ft³ (.16 gm/cc).

FEEDERS FAST **5-DAY ASSEMBLY**

FEEDERS FAST **5-DAY ASSEMBLY**

Model	Tray Type	Control	Tray Width		Tray Length		Capacity*		Part No.
			in	mm	in	mm	cu ft/hr	cu m/hr	
HS26	Medium Flat	A	5	127	22	559	85	2.41	13264720
HS26	Wide Flat	A	7	178	20	508	120	3.40	13264721
HS36	Narrow Flat	B	6	152	36	914	102	2.88	13260820
HS36	Medium Flat	B	8	203	30	762	137	3.88	13260821
HS36	Wide Flat	B	10	254	24	610	170	4.81	13260822
HS46	Wide Flat	B	14	356	24	610	235	6.65	13315521
HS46	Wide Flat	B	12	305	30	762	200	5.66	13315520
HS46	Narrow Flat	B	10	254	38	965	170	4.81	13090222
HS46	Medium Flat	B	14	356	30	762	235	6.65	13090223
HS56	Narrow Flat	B	12	305	42	1067	200	5.66	13144322
HS66	Medium Flat	B	14	356	60	1524	235	6.65	13119922
HS66	Wide Flat	B	16	406	48	1219	460	13.02	13119921

Model	Tray Type	Control	Tray Width		Tray Length		Capacity*		Part No.
			in	mm	in	mm	cu ft/hr	cu m/hr	
HD36	Narrow Flat	D	6	152	36	914	175	4.96	13335820
HD36	Medium Flat	D	8	203	30	762	230	6.51	13335821
HD36	Wide Flat	D	10	254	24	610	290	8.21	13335822
HD46	Wide Flat	D	12	305	30	762	400	11.32	13090120
HD46	Wide Flat	D	14	356	24	610	410	11.60	13090121
HD46	Narrow Flat	D	10	254	38	965	290	8.21	13090122
HD46	Medium Flat	D	14	356	30	762	410	11.32	13090123
HD56	Narrow Flat	D	12	305	42	1067	350	9.91	13072522
HD66	Medium Flat	D	14	356	60	1524	410	11.32	13296722
HD66	Wide Flat	D	16	406	48	1219	460	13.02	13296721
HD76C	Narrow Flat	D	18	457	96	2438	1200	34	201902738G2

All prices and specifications are subject to change without notice. Terms and conditions of sale are available at www.eriez.com.

* Capacities are based on dry sand weighing 100 lb/cu ft.

Electromagnetic Heavy Duty Feeders



58B

MODEL B FEEDERS

Eriez Electromagnetic Heavy Duty Vibratory Feeders can be used to convey abrasive products evenly and efficiently. These units are often used to feed material out of a hopper onto a belt or feed material to a crusher or screen.

FEATURES:

- Electro-permanent magnetic drive
- Low power consumption
- 10-degree down slope
- Suspension mounting
- Painted mild steel tray
- CE and CSA approved
- 115-volt, 60Hz, 1-phase AC operation (58B)
- 460-volt, 60 cycle, 1-phase AC operation (65B, 75B, 85B)
- Replaceable abrasion resistant steel liners (65B & 75B)
- Replaceable UHMW liners (85B)



65B

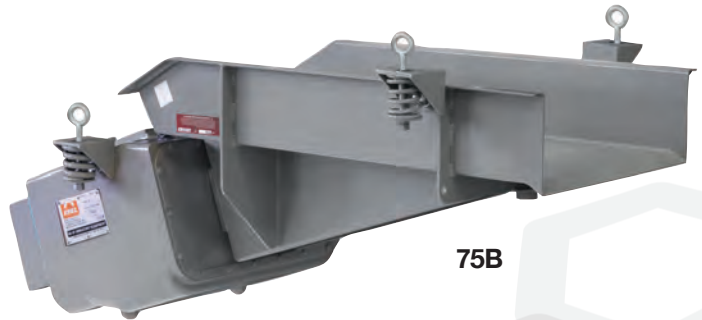

75B



85B

Model	Tray Type	Control	Tray Width		Tray Length		Capacity*		Part No.
			in	mm	in	mm	ton/hr	m tons/hr	
58B	Medium Flat	C	14	356	36	914	70	64	133594E
65B	Medium Flat	E	18	457	48	1219	112	144	163168
75B	Medium Flat	F	24	610	60	1524	205	186	163167
85B	Medium Flat	G	30	762	72	1829	270	245	163166

* Capacities are based on dry sand weighing 100 lb/cu ft. and tray mounted at a 10° downslope
All prices and specifications are subject to change without notice. Terms and conditions of sale are available at www.eriez.com.

Controls



UniCon



UniCon HC



G30

UniCon Models

Our UniCon line of controls offers excellent control of a wide range of electromagnetic feeders with the features customers require: Analog input (4-20 MA or 0-10 VDC), remote on/off and includes a standard NEMA 12 enclosure.

UniCon HC Models

This high power line-up of controls offers excellent controllability of our heavy duty electromagnetic feeders with the features customers require: Analog input (4-20 MA), remote on/off and optional accelerometer feedback for precise control of tray deflection. Comes in a standard NEMA 4 enclosure.

G30 Control

The G30 includes the standard features to meet most any application requirements; Analog input (4-20 MA or 0-10 VDC), remote on/off and optional accelerometer feedback for precise control of tray deflection. Includes a standard NEMA 12 enclosure.



Control	Part No.	UniCon	CE	UL	CUL
A	44559807E	N 12 UN/115-2A-FW NSF	✓	✓	✓
B	44559804E	N 12 UN/115-6A-FW NSF	✓	✓	✓
C	44559801E	N 12 UN/115-15A-FW NSF	✓	✓	✓
D	133542*	N 12 G30HZ	✓		
E	145508E	N 4 UNHC/460-5A	✓	✓	✓
F	145509E	N 4 UNHC/460-10A	✓	✓	✓
G	145510E	N 4 UNHC/460-20A	✓	✓	✓
H	145511E	N 4 UNHC/460-25A	✓	✓	✓

* Requires fusing and tag.

All prices and specifications are subject to change without notice. Terms and conditions of sale are available at www.eriez.com.

Electromagnetic Bin Vibrators

Eriez offers twelve AC drive units to improve flow of hard-to-handle materials in bins, hoppers and chutes.

Our unique magnetic drive circuit provides a simple yet powerful solution to difficult material flow applications. These vibrators, with their totally enclosed patented magnetic drive, can be used for applications ranging from the tiniest hopper to huge bunkers with reinforced heavy steel plate and liners.

The concentrated vibration, with its powerful positive drive in both directions, applies a superior action to bin walls. This results in more economical, more efficient flow of hard-to-handle materials.

FEATURES:

- Electro-permanent magnet drive
- AC operation
- Simple controls
- Encapsulated coils
- “Pinpoint” vibration
- Enclosed drive element
- Low power consumption
- Dust-tight enclosure
- CE and CSA approved
- 115V / 60 Hz

Model D20N

With bin capacity up to 5 cu. ft. (0.14 cu. m), the 20N is ideal for many light-duty applications. Hopper walls should be 18 ga to 3/32 inches thick (1.3-2.4 mm).

Model D30N

With bin capacity up to 15 cu. ft. (0.4 cm), the 30N is ideal for many light-duty applications. Hopper walls should be 3/32 to 1/8 inches thick (2.4-3.2 mm).

Model D30P

Bin capacity up to 20 cu. ft. (0.57 cu. m). For medium-duty applications, this model effectively handles a wide variety of hard-to-move materials. Hopper walls should be 1/16 to 1/8 inches thick (1.6-3.2 mm).



Model D40P

Bin capacity up to 3 tons (2.7 MT). For medium-duty applications, this model effectively handles a wide variety of hard-to-move materials. Hopper walls should be 1/16 to 1/8 inches thick (1.6-3.2 mm).

Model D55P

With bin capacity up to 18 tons (16.3 MT), this heavy-duty impact model is designed for larger capacity applications. Its powerful action makes it ideally suited for difficult material-moving jobs. Hopper walls should be 1/4 to 5/16 inches thick (6.4-8 mm).



Model	AMP	Control	Part No.
D20N	0.6	A	101642E
D30N	1.5	A	101657E
D30P	0.5	A	101680E
D30S	0.5	A	10168301
D40P	1.4	A	101711E
D40S	1.4	A	10171801
D50S	1.6	A	10172501
D55P	4.0	B	101907E
D55S	4.0	B	10190907

All prices and specifications are subject to change without notice. Terms and conditions of sale are available at www.eriez.com.

ERV - Electric Rotary Vibrators



Eriez' range of rotary vibrators is the result of 40+ years of vibratory experience and analysis, ensuring long-term durability. The standard ERV models are constructed for wet and dusty environments eliminating the concerns of environment conditions.

These vibrators are effective flow-aid devices to move material efficiently through small hoppers to large bunkers. The elliptical action of the ERV helps settle material in bags, boxes or other materials for shipping or storage.

FEATURES:

- Suitable for washdown and dusty environments
- Durable powder coat finish
- Tropicalized windings
- Continuous operation at 100% force output
- Adjustable eccentric weights to set force output
- Rugged construction with high-quality bearings
- Suitable for Class II, Div. 2, group F, G
- ETL approved
- Xpress models are 115V / 60Hz / 1-ph operation

Selection criteria for ERV model

Max. Material Weight in Hopper		3600 rpm Single Phase	Typical Hopper or Chute Wall Thickness
Content (Kg)	(Lb)		
998	2200	ERV 220/2M	1/8 – 3/16 in
1996	4400	ERV 440/2M	3/16 – 1/4 in

ERV 2 Pole Vibrators (3600 RPM) - These high frequency models are well suited to address the majority of hopper and chute applications. Materials that are more than 25 lb/ cu ft typically respond well to high frequency vibration.

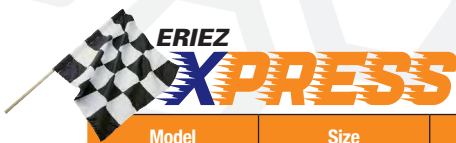

Model	Size	RPM	Part No.
ERV220/2m	10	3600	453797E
ERV440/2m	20	3600	453798E

All prices and specifications are subject to change without notice. Terms and conditions of sale are available at www.eriez.com.



ERIEZ

GLOBAL LEADER IN SEPARATION TECHNOLOGIES

HEADQUARTERS

2200 Asbury Road • Erie, PA 16506-1402 U.S.A.
1-814-835-6000 • eriez@eriez.com • www.eriez.com



AUSTRALIA
Epping, Victoria
+61 3 8401 7400



BRAZIL
Belo Horizonte, Minas Gerais
55 31 3281 9108



CANADA
Delta, British Columbia
+1 604-952-2300



CHILE
Las Condes, Santiago
56 2 29523400



CHINA
Qinhuangdao and Tianjin
86-22-8390-4608



GERMANY
Recklinghausen
+49 (0)160 94179313



INDIA
Athipet, Chennai
91-044-2652-5000



JAPAN
Urayasu, Chiba
+81-47-354-6381



MEXICO
Querétaro, Tlalnepantla
52 555 321 9800



PERÚ
Surco, Lima
51 1 719 4150



SOUTH AFRICA
Boksburg, Gauteng
27-11-444-9160



UNITED KINGDOM
Bedwas, Caerphilly
44-29-2086-8501



UNITED STATES
Erie, Pennsylvania
1-814-835-6000



Note: Some safety warning labels or guarding may have been removed before photographing this equipment.
Eriez, Eriez Flotation and Eriez Magnetics are registered trademarks of Eriez Manufacturing Co, Erie, PA