

Installation, Operation and Maintenance Instructions



**ELECTRIC
SUMP CLEANER
50 GAL./120V**

Table of Contents

ERIEZ SUMP CLEANERS

SAFETY INFORMATION.....	3
CONVENIENCE FEATURES	4
WARRANTY	4
ASSEMBLY	5
OPERATION.....	5
OPERATING TIPS.....	7
OPERATING EFFICIENCY TIPS	7
MAINTENANCE	8
TROUBLESHOOTING	9
SPARE PARTS LIST	10



Safety Information

SPECIAL NOTE: TO AVOID PERSONAL INJURY, BEFORE OPERATING A 120 VOLT ELECTRICALLY POWERED SUMP CLEANER, THE CUSTOMER MUST CONNECT THE 3-WIRE ELECTRICAL CORD TO A SUITABLE POWER SUPPLY THAT IS ALSO PROPERLY GROUNDED. THE GREEN WIRE IN THE ELECTRICAL BOX OF THE SUMP CLEANER IS THE GROUND WIRE. THE CUSTOMER'S GROUND SOURCE MUST BE IN ACCORDANCE WITH ARTICLE 250 OF THE NATIONAL ELECTRIC CODE (NEC) OR OTHER SUITABLE REGULATION IF IN A COUNTRY OTHER THAN THE UNITED STATES OF AMERICA.

1. To avoid possible injury, before operating this Sump Cleaner, read this manual for full operating instructions.
2. Always block the wheels of the Sump Cleaner to prevent unintentional rolling. Accidental rolling on a sloped floor, if bumped, could cause injury or property damage.
3. Wear eye goggles to protect your eyes from splashing liquids. This is important, even when you know the fluids themselves are not caustic or otherwise harmful. Metal particles suspended in the liquid could still cause serious eye injury.
4. Check hose, nozzle, cleaning tool, and hose cap connections for leaks. To minimize chances of spilling, handle cleaning tools and hoses carefully during operation, and replace hoses before deterioration results in leaks.
5. Immediately clean up any spilled coolant to avoid slippery floors and dangerous falls.
6. If it is necessary to use the Sump Cleaner in an aisle or other traffic area, position it to minimize the likelihood of being struck by trucks, forklifts or other equipment in transit. Exercise a reasonable lookout for such hazards during operation.
7. Whenever removing or reseating the filter basket (maximum chip/sludge capacity is approximately 200 to 300 pounds, or 90 to 136 kg), keep hands and fingers out from under the basket lip.
8. Keep clear from beneath the basket when trying to empty its contents, or if necessary, to pull out the polypropylene liner. Use tools of appropriate strength and length to let you perform these operations safely.
9. Frequently check the basket's hoisting rings for signs of rust. If the rings are heavily corroded, replace the basket with a new one.
10. Be sure the suction inlet ball valve is fully closed before operating the Sump Cleaner in the discharge mode. The tank is pressurized in this mode, sometimes to as much as four to five PSIG.
11. The electric motor on your cleaner is designed to be used only with the electric supply specified on the Specifications Page of this manual, and on the motor enclosure. Use with any other type of connection or power source may damage the equipment or cause personal injury.
12. **Do NOT use this unit for solvents, flammable cleaners (low flash point) or other volatile liquids.** Use it only for water-soluble coolants and for cutting or grinding oils.
13. Operating temperature of standard suction and discharge hose is 150°F.
14. This equipment is to be operated and maintained by authorized personnel only.
15. **MAGNESIUM CHIPS OR DISSIMILAR METALS.** In the presence of water, magnesium can release hydrogen gas, which is highly flammable and, in the proper proportions with air, can be explosive.

When a Sump Cleaner is used on a metalworking fluid application generating magnesium chips, certain precautions must be taken to ensure that any hydrogen gas is dissipated into the atmosphere and to make sure the hydrogen does not accumulate in the Sump Cleaner.

This is accomplished by promptly removing any magnesium chips from the Sump Cleaner basket. In addition, a maintenance schedule should be established by the customer that would eliminate buildup of sludge in the bottom of the Sump Cleaner. Finally, the unit should be stored with the basket empty of chips, the chip basket lid removed, the coolant discharge nozzle removed and hoses open to the atmosphere. Taking these precautions will minimize the risk of hydrogen gas generation and accumulation.

CAUTION: All components used to lift the basket (steel cable, hooks, crane, etc.) must have a minimum capacity of 1,000 pounds (455 kg).

Safety Information (cont.)

On an application where dissimilar metals are machined, there is a chance for spontaneous combustion to occur. Typically, metalworking facilities that machine various metals are aware of this and may have experienced problems in chip hoppers due to the presence of two or more metals, water, and tramp oil. The precautions mentioned in this paragraph will minimize or eliminate the potential for spontaneous combustion.

PRESSURIZATION SAFETY ISSUES

Your Sump Cleaner is designed to operate under pressure when discharging fluids. The optimal safe operating pressure should always be less than 7 PSI and your unit was set at below this level at the factory. Your unit should never be operated at pressures exceeding factory settings. Tanks or vessels, which are pressurized beyond this pressure, require ASME certification as "Pressure Vessels" and the Sump Cleaner has not been certified for such high-pressure operation. Operating a Sump Cleaner at pressures above this creates a serious risk of injury to workers and damage to property.



WARNING

ALTERING OR MODIFYING SAFETY REGULATING FEATURES TO DEFEAT THEM MAY RESULT IN THE TANK BECOMING OVER PRESSURIZED. OVER PRESSURIZATION MAY CAUSE THE EXPLOSIVE RUPTURE OF THE TANK RESULTING IN SERIOUS INJURY OR DEATH TO WORKERS AND DAMAGE TO PROPERTY. MODIFYING OR INTENTIONALLY DEFEATING THESE IMPORTANT SAFETY FEATURES WILL CONSTITUTE THE INTENTIONAL MISUSE OF THE EQUIPMENT VOIDING ALL WARRANTIES.

The Sump Cleaner is to be adjusted and/or repaired only by qualified service personnel. If these personnel need more information than is provided in this manual, they should contact Eriez Hydroflow.

STANDARD SAFETY FEATURES

Although your Sump Cleaner is an inherently safe machine, it could pose the potential for hand and finger injury when the operator has to remove the filter basket from the unit and empty it of chips and sludge. For this reason, Eriez Hydroflow, has two safety features on this machine:

- The filter basket automatically centers itself within the unit's basket support as it is being hoisted out of the machine. This eliminates the need for the operator to physically guide the heavy, chip-laden basket as it is being raised. This significantly reduces the opportunity for the operator to receive hand injury.
- The unique tipping-basket design enables the operator to empty the filter basket without the need for special tools. The basket is removed from the unit, positioned over a chip hopper or similar device, and then slowly lowered until in contact with the materials already in the hopper. The basket is then lowered further while tipping the basket with the handle on the bottom of the basket.

Convenience Features

- Low rolling resistance, high maneuverability design Sump Cleaner features high impact, fiber reinforced, hard plastic casters and wheels for low rolling resistance, whether the unit is empty or full.
- Swing-bolt basket lids make lid removal and replacement easy and fast.
- Our lightweight, gasoline pump-type nozzle makes discharging the sump cleaner easier.
- "Smooth 90°" filter basket suction inlet virtually eliminates suction hose "chip jams".
- The electronic float overfill protection assembly eliminates motor damage and coolant spills by shutting off the motor when the tank is full.

Warranty

Eriez Hydroflow equipment warranty is defined in Eriez standard Terms and Conditions of Sale provided at the time of invoice and also available on www.eriez.com or by contacting Eriez. Equipment warranty includes all sump cleaners and is subject to the following exceptions and clarifications:



1. Gasoline and LP Gas internal combustion engines are not covered by Eriez warranty but rather are covered by the standard warranty of the engine manufacturer, which varies from model to model. Copies of the specific warranty of the manufacturer will be shipped with the unit and such warranties and limitations are incorporated by reference herein. Upon request, copies of the engine manufacturer's warranty will be provided in advance of shipment.
2. For units mounted on mobile platforms or other similar sub-assemblies, such as trucks, carts, or self-propelled platforms, Eriez makes no warranties for such sub-assemblies manufactured by third parties and specifically disclaims any warranties with regard thereto, including implied warranties of merchantability or fitness for a particular use. The only warranties as to such sub-assemblies are those extended to purchaser directly by the third-party manufacturer, and such warranties are subject to all of the terms, conditions, and limitations of the third party's warranties and are enforceable only against said third-party manufacturer; and Eriez is not underwriting or guaranteeing their warranties, nor is Eriez an agent of said third-party manufacturers for purpose of pursuing warranty claims or making service arrangements or any other purpose. Copies of such third-party sub-assembly manufacturers' specific warranty information will be shipped with the unit, and such warranties and limitations are incorporated by reference herein. Upon request, copies of sub-assembly manufacturers' warranty information will be provided in advance of ordering or shipment.
3. On all units, including Sump Cleaners and other sump cleaning equipment, all gaskets, hoses, filter basket-sleeves, cleaning tools, wheels, casters and batteries are considered expendable or ordinary maintenance items and are expressly exempted from this warranty and are not covered by any other warranty, express or implied.
4. Component parts returned for replacement must show the original unit serial number from which they were removed. Parts returned without the aforementioned serial number will be replaced at established replacement prices. Vacuum and pressure relief valves are preset at the factory. **ALTERATION OF THE SETTING EXCEPT WITH THE SPECIFIC AUTHORIZATION OF ERIEZ OR ITS AUTHORIZED REPRESENTATIVES WILL VOID FACTORY WARRANTY.**

Assembly

1. Refer to the drawings at the end of this manual for location of the items discussed below and the following sections of this manual.
2. Remove the cover of the basket. Keep hands and fingers clear from the edges of the filter basket.
3. Take out the following items:
 - a. Filter basket.
(Factory assembled with filter sleeve).
 - b. Spare filter sleeve.
 - c. Discharge hose with nozzle.
 - d. Suction hose.
 - e. Cleaning tool (from metal tube on tank body).
4. Keeping hands and fingers out from under the edge of the basket, reseal the basket filter inside the unit. Replace the tank lid and clamp it down with the swing bolts provided.
5. Attach the suction hose to the intake connection on the tank lid. Attach the cleaning tool to this hose, and coil the hose around the basket end of the unit. The cleaning tool easily stows in the metal tube provided.
6. Couple the discharge hose to the discharge connection, and coil the hose over the support provided on the opposite end of the machine. Attach the discharge nozzle to the discharge hose with the quick-disconnect coupling provided.

Operation

1. Before operating this equipment for the first time, and periodically thereafter, review the SAFETY INFORMATION beginning on page three of this manual.
2. Suction vacuum and discharge pressure are applied independently in this unit by moving a hose attached to the tank to either the suction fitting or the discharge fitting as required.
3. Connect the Sump Cleaner to the electrical supply specified on the electrical box housing the motor. For North America, this is 120 VAC, single phase, 60 Hz.

Operation (cont.)

4. Suction Operation:

- a. Connect the black hose to the suction port on the electrical box containing the motor assembly.
- b. Open suction inlet valve fully with suction hose properly attached. **MAKE SURE THAT THIS VALVE IS EITHER FULLY OPEN OR FULLY CLOSED AT ALL TIMES. FAILURE TO DO SO WILL ALLOW PARTICULATE MATTER TO ENTER THE VALVE SEAT , WHICH COULD SEIZE THE VALVE.**
- c. Make sure that the discharge hose is connected, and that the discharge nozzle is attached and closed.
- d. Turn on the Sump Cleaner by placing the “on-off-on” switch into the “SUCTION ON” position. **NOTE: THE FLOAT SWITCH WILL ONLY WORK WHEN SUCTION ON IS SELECTED, IT IS NOT WIRED INTO THE DISCHARGE ON CIRCUIT.**
- e. Vacuum coolant, chips, and sludge from the machine sump.
- f. An electric float located in the tank will rise with the rising liquid level in the tank and shut off the motor when the tank is full. When this occurs, Sump Cleaner will stop sucking.
- g. When you are done vacuuming coolant and chips, turn off the Sump Cleaner.

5. Discharge Operation: To return filtered, chipfree coolant to the machine, to wash down the machine, or to discharge coolant into your recycling or disposal system:

- a. Close the suction inlet valve completely.
- b. Move the black hose from the suction inlet (on the electrical box housing the motor assembly) to the discharge fitting.
- c. Turn the unit on by placing the on-off-on switch to the “DISCHARGE ON” position.
- d. Depress the handle of the discharge nozzle to begin the fluid flow.
- e. When discharging operation is complete, turn the unit off.

- f. The Sump Cleaner will discharge nearly all the fluid in the bottom of the tank compartment. This is unimportant if the unit remains in reasonably frequent use on a single coolant. If different coolants are used, or the unit will be stored for some time, remove the discharge hose and hose fitting on the bottom of the unit to drain the unit completely.

6. To empty the Filter Basket:

- a. Remove lid.
- b. Attach an OSHA approved lifting device to basket rings. **CAUTION: All components used to lift the basket (steel cable, hooks, hoist, crane, etc.) must have a minimum capacity of 1,000 pounds or 455 kg.**
- c. To avoid the basket binding in the tower during removal, position the lifting device (e.g. crane) directly over the center of the basket.
- d. Hoist the basket. Keep hands and fingers clear. If the basket is not exiting the center of the tower, return (lower) basket to the Sump Cleaner tower. Reposition the lifting device so that the basket exits the center of the tower.
- e. **DO NOT TOUCH BASKET DURING REMOVAL.**
- f. Position the basket over the waste receptacle and lower until in contact with material in waste receptacle.
- g. Tip the basket on its side and over to empty. The handle on the bottom of the chip basket can be used to assist with this effort.

7. Check the filter sleeve. If it is badly soiled or clogged, turn it inside out and wash it with a non-solvent cleaning solution. Replace filter when necessary.
8. Inspect the basket hoisting rings for signs of rust. Replace the basket assembly with a new one if the rings are heavily corroded.
9. Keeping hands and fingers from under the basket lip, reseal the basket in the tank and fasten down the tank lid.

THE SUMP CLEANER IS TO BE ADJUSTED AND/OR REPAIRED ONLY BY QUALIFIED SERVICE PERSONNEL. IF THESE PERSONNEL NEED MORE INFORMATION THAN IS PROVIDED IN THIS MANUAL, THEY SHOULD CONTACT ERIEZ HYDROFLOW.



Operating Tips

The Sump Cleaner has been designed to make the job of proper machine tool coolant sump cleaning as easy as possible for the operator of the Sump Cleaner. It has the power necessary for true, high-performance sump cleaning. It will vacuum from the sump anything that will pass through its two inch diameter suction hose, and it will suck up water miscible products (coolants, cleaners) at nearly 85 gallons per minute, or 320 liters per minute.

At the same time, all Sump Cleaners are designed with operator safety, ease of operation, and maintenance as foremost considerations.

Although the Sump Cleaner is designed for operator safety, before using the Sump Cleaner for the first time (and periodically thereafter for a review) read the section of this Operator's Manual entitled "Safety Information", pages 3-4.

Operating Efficiency Tips

Here are some tips to improve the operating efficiency of your Sump Cleaner:

- Follow the Sump Cleaner maintenance schedule carefully. Preventive maintenance is far less expensive than major repairs.
- Clean your Sump Cleaner about once a month, or whenever sludge or fines become noticeable in the bottom of the tank.
- Rinse the unit with plain water and drain it completely by removing the drain plug/discharge hose whenever changing from one brand or type of coolant to another. There can be compatibility problems created by mixing some products, so avoid contamination. (Remember to replace the plug.)
- It is better to have one Sump Cleaner for use with water-soluble coolants and another for use with cutting oils. If you must use one unit for both, the Sump Cleaner must be thoroughly cleaned when switching products. If possible, purchase a filter basket and a set of hoses for each product. (The Sump Cleaner tank is not too hard to clean, but the hoses and filter basket are.)

Organize your machine-pumping schedule so that during one week, you are pumping machines running water soluble products and the next week you are pumping machines running cutting oils. This minimizes cleaning the Sump Cleaner.

- When vacuuming out machines using watermiscible products (coolants, cleaners), put the cleaning tool on the bottom of the sump, and remove fluid and chips together.
- When vacuuming out machines using cutting or grinding oil, remove the oil first and then vacuum up the chips and fines.
- In the event you experience a stoppage in the unit's suction hose, the suction hose's cleaning tool should be held and pointed into the machine sump (NOTE: DO NOT POINT IT AT PERSONNEL) and the Sump Cleaner started in the discharge mode.

Usually, the discharge pressure generated is sufficient to clear the stoppage by blowing the obstruction back into the machine sump. If the stoppage is not cleared in this manner, remove the hose from the fitting, and physically remove the obstruction.

- Your Sump Cleaner can be used as a portable filter for your grinders that have only settling tanks. Vacuum out the coolant and the swarf and return filtered coolant to the grinder tank. If the standard polypropylene filter sleeve does not provide adequate filtration, fit the basket with our disposable 20-micron paper filter bag.

Note: Extremely fine grinding particles, such as carbide grinding swarf, will pass through even the paper filter. Although the Sump Cleaner will do an excellent job of removing the swarf from the grinder, you will experience a rapid accumulation of fines in Sump Cleaner tank.

- If you are experiencing a problem in disposing of chips or swarf because of too great a moisture content, your Sump Cleaner can be used as a chip "drier". Vacuum out your machine to remove all chips and fines, and then empty the Sump Cleaner of all coolant in the normal manner. Open the suction inlet ball valve. Change black hose from "discharge" to "suction", then start the unit and allow it to run for 10 to 15 minutes. Air drawn into the Sump Cleaner will draw excess moisture from the chips and allow them to be disposed of more easily. Be prepared to experiment with drying times; getting the chips or swarf too dry will make it difficult to remove them from the filter basket.

Operating Efficiency Tips *(cont.)*

- Always empty the filter basket immediately after using the Sump Cleaner. Allowing the chips or swarf to remain in the basket and the basket in the unit overnight or over the weekend can cause the chips or swarf to corrode (rust) into a solid mass which is virtually impossible to remove from the basket. This problem is especially pronounced with cast, nodular and malleable irons.
- Do NOT alter the unit's vacuum and pressure settings. You will not improve your Sump Cleaner's performance and you will void its warranty.
- Do NOT use your unit for solvents, volatile or low flash point fluids of any type. It is designed for use with coolants, cutting oils, water-soluble machine cleaning solutions and parts washing compounds only.
- When pumping out of below-floor-level pits you can increase the efficiency of the suction by drilling a small hole (3/16", or 4 mm) in the cleaning tool below where the hose is attached at the cleaning tool.

By keeping this hole above the fluid level, you allow more air to enter the hose. That helps to move the fluid up the hose faster and allow pumping out of deeper pits.

If you have any questions about your unit or its suitability for a particular job, please contact Eriez.

Maintenance

1. Check the filter basket's polypropylene mesh filter sleeve frequently. If it is badly soiled or clogged, remove the retaining ring on the inside of the basket. Lift out the sleeve, turn it inside out, and wash in a suitable cleaner.
2. If the filter sleeve is torn, or if it is soiled or clogged to the point where simple cleaning is inadequate, replace the sleeve with a new one.
3. To install a new sleeve, fit the sleeve inside the basket, and fold the top edge over forming a smooth edge. Make two small holes in the sleeve in order to slide it over the basket's lifting rings. Push the rings through. Use the supplied Ty-Rap cables to go over the sleeve where it is folded over the top lip of the basket. Pull the ties tight so the liner will stay in place.
4. Frequently check the basket lifting rings for signs of rust. If the rings become badly corroded, replace the basket with a new one.
5. If the filter sleeve is maintained in good condition, only fine particles should normally settle out in the bottom of the tank. Remove these periodically by removing the discharge hose at the 90° elbow, and with the filter basket out of the Sump Cleaner, flush the tank with a water hose.
6. Periodically, while the basket is out of the tank, check the tank interior for sludge buildup. If such a buildup starts to get thick, use an appropriate tool to scrape it off the tank walls. Remove the discharge hose and hose fitting from the bottom of the tank, and flush the tank with a water hose.
7. Periodically, check hoses for deterioration, and replace with new ones if leaks have developed or appear imminent. Always coil hoses properly over the supports provided when not in use.

Other than the routine maintenance operations specified above, only authorized service personnel should undertake adjustments and/or repairs to this equipment. If these personnel need more information than is provided in this manual, they should contact Eriez Hydroflow.



Maintenance Schedule

Weekly	Monthly	Every 6 Months	MAINTENANCE SCHEDULE FOR ELECTRIC SUMP CLEANERS	MAINTENANCE LOG					
				Date Placed Into Service:					
				Record Date of Service Below:					
			Inspect suction and discharge hoses. Replace as needed.						
			Inspect filter basket sleeve and replace as needed. Inspect basket lifting rings for corrosion.						
			Inspect tank for sludge buildup; clean as needed.						
			Grease wheels and casters; use no.2 bearing grease.						

Troubleshooting

SUMP CLEANER - ELECTRIC - 120 VOLT TROUBLESHOOTING CHART		
PROBLEM	PART TO CHECK	POSSIBLE SOLUTION
Unit does not start	Power supply	Make sure that the plug is fully seated in a wall outlet of proper voltage.
	Fuses	Check electrical supply system fuses or circuit breakers. Replace if necessary.
	Motor brushes	Check brushes; replace as needed.
Insufficient suction or no suction	Basket	Check for full basket; empty. Check if basket is blinded off; clean or replace.
	Hoses	Check for obstructions; physically remove. Check for cracks or holes; replace.
	Air leakage	Check all hose connections for tightness. Make sure female quick disconnect fittings have gaskets in place. Check top gasket on filter basket and repair or replace.
	Discharge nozzle	Check that discharge nozzle is fully closed and in place.
Insufficient discharge pressure	Suction valve	Check that suction inlet ball valve is fully closed.
Will not discharge	Discharge hose	Check hose for blockage. Physically remove obstruction.
	Tank	Check for build up of fines and swarf in bottom of tank. Clean as necessary.
	Discharge nozzle	Check to see if nozzle is plugged. Physically remove obstruction.
	Suction valve	Be sure suction inlet ball valve is fully closed.
Portability	Hard to push	Check for worn wheels or casters; replace. Check wheel and caster bearings; grease or replace. Rough floors; use a forklift truck for transport.

Spare Parts List

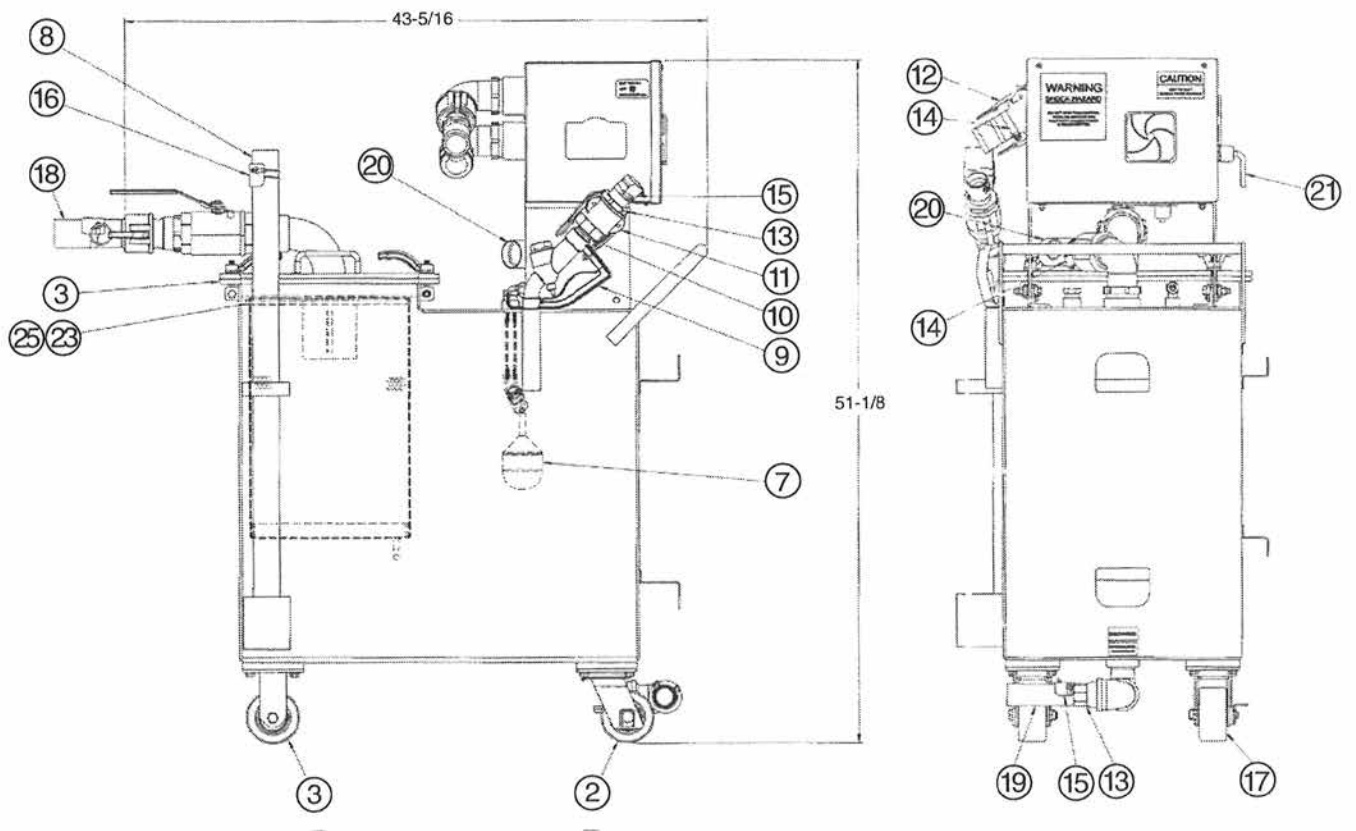
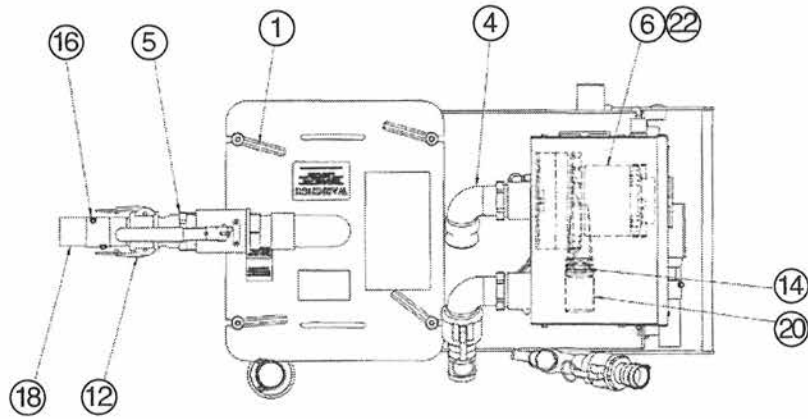

Part #	Stock #	Description
25	*60-1450	Liner for Strainer Basket
23	*31-3270	Ty-Rap Cable
22	52-1420	Motor Brushes (Spares)
21	30-2055	Power Cord
20	41-2230	Black Hose 2"/2 ft long
19	41-2090	Orange Hose 1.5"/10 ft long
18	41-2110	Orange Hose 2"/10 ft long
17	43-1040	Swivel Caster with Brake
16	41-1010	Spiral Hose Clamp
15	41-0980	Spiral Hose Clamp
14	41-0990	Hose Clamp
13	42-1140	Quick Disconnecting Fitting
12	42-0133	Quick Connect Poly Fitting
11	42-1200	Quick Disconnect Aluminum Fitting
9	60-1960	Gas Nozzle
8	60-1220	Cleaning Tool
7	38-1160	Float Switch
6	52-1400	Motor, Vacuum 120V
5	42-0132	Quick Connect Poly Fitting
4	42-0146	Quick Disconnect Poly Elbow
3	43-1020	Rigid Caster
2	43-1060	Swivel Caster
1	40-1150	Adjustable Handle

* = Recommended to purchase as a set.





HydroFlow, Eriez and Eriez Magnetics are registered trademarks of Eriez Manufacturing Co, Erie, PA

©2018 Eriez Magnetics All Rights Reserved



World Authority in Separation Technologies

Headquarters: 2200 Asbury Road, Erie, PA 16506-1402 U.S.A.

Telephone: 814-835-6000 • Fax: 814-838-4960

Web Site: <http://www.eriez.com> e-mail: eriez@eriez.com



Manufacturing Facilities: AUSTRALIA • BRAZIL • CANADA • CHINA • INDIA • JAPAN • MEXICO • SOUTH AFRICA • UNITED KINGDOM • UNITED STATES