

Installation, Operation and Maintenance Instructions



SUSPENDED PERMANENT MAGNETIC SEPARATOR MODEL TP

ERIEZ WORLD HEADQUARTERS: 2200 ASBURY ROAD, ERIE, PA 16506-1402 U.S.A.
WORLD AUTHORITY IN SEPARATION TECHNOLOGIES

Introduction

This manual details the proper steps for installing, operating and maintaining the Eriez Suspended Permanent Magnetic Separator.

Careful attention to these requirements will assure the most efficient and dependable performance of this equipment.

If there are any questions or comments about the manual, please call Eriez at 814-835-6000 for Magnetic Separator assistance.



CAUTION

Safety labels must be affixed to this product. Should the safety label(s) be damaged, dislodged or removed, contact Eriez for replacement.

Table of Contents

ERIEZ SUSPENDED PERMANENT MAGNETIC SEPARATOR - MODEL TP

INTRODUCTION.....	5
Responsibility	5
Using This Manual.....	5
GENERAL HEALTH AND SAFETY / WARNING NOTICES.....	5
Health and Safety Factors	5
Safety	5
Lifting Aids	5
Noise	5
Lethal Voltages	6
Moving Machinery	6
Heat.....	6
Electronic Cardiac Implants.....	6
Electromagnetic Compatibility	6
Warnings and Safety Instructions	6
Guards and Barriers	6
Maintenance Staff.....	6
Responsibility	6
GENERAL RISK AND HAZARD ASSESSMENT.....	7
Guards and Barriers	7
Statement of Designed Method of Operation	7
Risk and Hazard Assessment Parameters	7
Residual Hazard Identification.....	7
Possible Hazards And Risk Assessment	7
Keywords and Symbols	8
Safety Advice.....	8
Belt Motor	8
General Warnings.....	9
Corrosive Materials.....	9
INSTALLATION	9
Shipping and Handling	9
Lifting.....	9
General.....	10
Magnet Position.....	10
Manual Cleaning Position 1.....	10
Self-Cleaning Position 1	11
Position 2.....	11



Table of Contents *(cont.)*

ERIEZ SUSPENDED PERMANENT MAGNETIC SEPARATOR - MODEL TP

Suspension Height	11
Burden Depth	12
Emergency Off Push Button	12
Lighting	12
COMMISSIONING.....	12
Self-Cleaning Separators	12
PREVENTIVE MAINTENANCE.....	15
Routine Maintenance.....	15
Daily.....	15
Weekly.....	15
Monthly	15
Quarterly.....	15
Yearly.....	15
General Safety Rule	15
Manual Cleaning Separators	15
Self-Cleaning Separators	16
Vulcanized Belt.....	16
Laced Belt.....	16
Bearing Relubrication	16
Drive Coupling Alignment	17
TROUBLESHOOTING AND RECOMMENDED SPARES	18
Manual Cleaning Units	18
Self-Cleaning Units.....	18
DISPOSAL OF SYSTEM.....	19
Gear Units	19
Motor Units	19
Magnets.....	19



Introduction

Responsibility

Eriez will not be responsible for any malfunction of equipment as a result of the customer's failure to follow the instructions detailed in this manual. If you have any questions regarding the information or instructions given in this manual, do not hesitate to contact your Eriez representative.

Using this Manual

This manual is intended solely for Eriez, "Suspended permanent magnet separator TP".

General Health and Safety/ Warning Notices

WARNING

This chapter contains important safety related information. It is strongly recommended that you familiarize yourself with the information in this chapter before proceeding through this user manual. Failure to do so could lead to the risk of injury or death.

Health and Safety Factors

There are several factors which have a bearing on the Health and Safety aspects concerned with the installation of this equipment. These are as follows:

Weight	The weight of the components
Noise levels (at workstation)	Noise levels may exceed the levels at which hearing protection is required
Voltages	Lethal voltages are used in the equipment
Moving machinery	Moving components are present in this equipment
Heat	High temperatures are generated during the operation of this equipment
Magnetic fields	The magnetic field created by this equipment can interfere with medical implants which may lead to catastrophic failure of the device

Safety

The electrical equipment employed in this product operates using potentially lethal electrical power and therefore should be treated with the utmost caution and respect. To avoid the possibility of personal injury or even death, the following points must be closely observed:

WARNING

- i) Never allow the equipment to be operated by untrained personnel.
- ii) Never allow the operation, maintenance or rectification of the equipment or its components to be carried out by personnel other than those who have been suitably trained and declared competent to carry out such tasks.
- iii) Never put the equipment back into use following maintenance or rectification until it has been checked by suitably trained and qualified staff and declared as safe to do so.
- iv) Never operate the equipment with any guards, panels or doors removed or open. Always ensure that they are in a serviceable condition, correctly secured and locked prior to switching on the equipment.
- v) Never modify the equipment or its components so that they will operate with any of the safety features disabled i.e. short circuited, linked out or by-passed in any way.

Lifting Aids

Personnel are to be aware of the weight of the equipment and its components and are strongly advised to use trained personnel and mechanical lifting aids wherever possible. To avoid the risk of injury, personnel are to ensure that prior to attempting an unaided lift the weight involved does not exceed any recommended limits identified by legislation, or any other relevant guidance, and that suitable protective clothing is worn.

Noise

Eriez has taken all reasonably practical measures to reduce noise to levels which are safe and without risk to the health of a normally fit operator. It is, however, possible that a noise level in excess of 80dBA may occur in the vicinity of the equipment. Customers should make sound level measurements of the equipment when installed and operating under normal load conditions within the rating of the equipment. This will take into account the equipment and its environment and enable the appropriate level of action to be determined in accordance with legislative guidelines applicable in the area of installation.

Lethal Voltages

Lethal voltages may be employed in this equipment and Warning Signs are displayed.

Moving Machinery

In some machinery linear moving components can be employed during the operation of the installation. The fitting of guards etc. to prevent access by operators is strongly recommended. Any additional guarding required due to additional hazards presented by the customer's environment/machinery is the responsibility of the customer.

Heat

During operation, heat may be induced into the equipment and its components, therefore direct contact with the equipment during or immediately following operation of the equipment should be avoided without handling equipment and protective clothing.

Electronic Cardiac Implants- equipment that contains magnets



It is possible for electronic cardiac implants to be affected by extraneous magnetic fields radiated by magnets and similar devices. Personnel, including visitors, fitted with such devices should therefore not stand in the immediate vicinity of the magnetic separator. Further information should be sought from the appropriate area medical authority or from information which can be sourced from the manufacturer of the implant. If in doubt, a distance of 10 foot radius is to be observed at all times. It is the customer's/operators responsibility to ensure that all personnel, including visitors are made aware of this hazard.

Electromagnetic Compatibility- equipment that contain magnets

1. This equipment has been so constructed that it does not cause excessive electromagnetic interference and is not unduly affected by electromagnetic interference.
2. This equipment should not be operated with any doors or panels open as this may reduce the effectiveness of the electromagnetic radiation and immunity screening.
3. Regular maintenance procedures as outlined elsewhere in this manual should be observed.

Warnings and Safety Instructions

The need to observe the warnings and safety instructions at all times cannot be emphasized too strongly and, in particular, the potentially lethal consequences of working on an electrical component with the mains supply switched on, and the risk of burns due to the temperature of treated wire and operating electrical equipment.

Guards and Barriers

1. The equipment supplied by Eriez is fitted with guarding as required to meet with the requirements of the Machinery Directive as listed in the Certificate of Conformity.
2. All our suspended magnetic separators are intended to be incorporated into an existing facility or machinery determined by the end user.
3. It is the customer's responsibility to install guards and barriers as required to prevent unauthorized access to the installation and protect the operators from any hazards present once the installation is complete.

Maintenance Staff

Only suitably qualified members of staff should attempt to maintain or rectify the installation or its components. It is the responsibility of the customer's qualified representative to ensure that following any maintenance or rectification tasks, all guards, safety interlocks and grounding circuits are correctly fitted, fully functional and the installation is in a safe condition prior to being operated.

Responsibility

Eriez cannot accept any responsibility for accidents or damage caused by over-riding the safety interlock circuits or non-compliance with any warnings issued in this user manual.



General Risk & Hazard Assessment

Guards and Barriers

The equipment supplied by Eriez is intended to be incorporated into an existing facility at the end users site. In some machinery, hot surfaces and moving components can be exposed during the separation process. It is the customer's responsibility to install guards and barriers as required to prevent unauthorized access to the installation and protect the operators from any hazards present once the installation is complete.

Statement of Designed Method of Operation

1. The installation was designed following a requirement from the customer on the method of operation of this installation. It is the responsibility of the customer to take responsibility for any associated hazards as a result of this requirement.
2. It is the responsibility of Eriez to make the customer aware of any hazards that may exist within the parameters specified.
3. The installation is designed to extract and separate tramp iron from a contaminated conveyor feed of substances. The process is continuous.

Risk and Hazard Assessment Parameters

1. The parameters for risk and hazard evaluation for the installation during normal working operation have been taken from the following instructions: Machinery Directive Risk Assessment.
2. It is the full responsibility of the customer to ensure that the surrounding environment is made safe for the operators, following all the recognized safety standards.

Residual Hazard Identification

1. This manual is only concerned with any hazards that may concern the operators within the parameters specified above.
2. Where possible protection has already been provided (i.e. selection of certified components) and so therefore these are no longer considered a hazard.

Possible Hazards and Risk Assessment

Separate risk assessments have been carried out and are all stored as part of the equipment technical file.



WARNING

DO NOT install commission or operate this machine until this manual has been carefully read.

This suspended permanent magnet has been designed to be "safe" when operated and maintained under the guidance of this manual.













WARNING

FIRE WARNING. Materials may get extremely hot and if mixed with combustible material and could cause a fire.

Keywords and Symbols

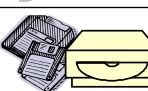
Please pay special attention to sections of text with these allocated symbols:

	General symbol for: Danger! Caution! Attention! Important!
	Risk of Electrical Shock Hazard
	Risk of Body Crush Hazard
	Injury by rotating blades Hazard
	Lifting Hazard
	Body Crush/Tip over Hazard
	This equipment contains magnetized material and must be treated with the UTMOST caution to safeguard against injury Do not allow the pole faces to face each other. Opposite polarity poles will come together with considerable force
	Before handling this equipment personnel with pacemakers or implants should confirm that their implants are not affected by magnetism. If in doubt do not approach within 10 foot radius of the magnet
	Take care when using ferrous tools or ferrous parts near the magnet as they can be attracted to the magnet with considerable force
	Do not place pre-recorded tapes, computer disks, or credit cards near the magnet box since this could cause erasure
	Do not drill or weld near the magnetic unit without first seeking the advice of ERIEZ

Safety Advice

 **WARNING**
The **SAFETY ADVICE** section on the next page **MUST BE READ** before any work is attempted.

Belt Motor

 **WARNING**
This may be controlled locally or remotely and could start up without warning.

General Warnings

1. When machinery is energized the operators should listen for any abnormal banging sounds or extreme vibration. If this is observed the machine should be de-energized and maintenance staff informed.
2. Warning Plates, Caution Plates and Safety labels on the equipment must not be removed or painted over. It is important these warnings and cautions are legible.

For equipment that can generate a strong magnetic field, operators should take the necessary precautions when handling ferrous material in the vicinity. Tramp iron may be attracted suddenly and unexpectedly to the magnet surface with the possibility of finger or limb entrapment, resulting in injury.

Corrosive Materials

Equipment parts used are appropriate to the intended mechanical and thermal stresses and capable of withstanding attack by existing or foreseeable aggressive substances.

The equipment is designed in accordance with directives and standards as stated on Declaration of Conformity and good engineering practice. It's the User's responsibility, to ensure chemical compatibility with the materials used.

If the equipment is likely to come into contact with aggressive substances, then it is the responsibility of the user to take suitable precautions that prevent it from being adversely affected, thus ensuring that the type of protection is not compromised. Aggressive substances - e.g. acidic liquids or gases that may attack metals or solvents that may affect polymeric materials.

Suitable precautions – e.g. regular checks as part of routine inspections or establishing from the materials data sheet that it is resistant to specific chemicals.

CAUTION

Machines can produce a strong magnetic field that will quickly attract magnetic tools and items. Extreme care must be taken to keep all magnetically attractive items away from the machine to avoid injury.

Installation

Shipping and Handling

The shipping company is always liable for any damage during transit to the goods that have been entrusted to the same. Before preparing the unit for installation and commissioning, a thorough visual inspection must therefore be carried out to check that the packaging is intact and that the unit presents neither visible damage or oil leaks. Also ensure that the units correspond to the order that was placed.

Any damage or complaints must be reported to Eriez and to the carrier by recorded delivery letter within 8 days from receiving the goods. Should one or more components be damaged, do not proceed with starting up the unit and inform Eriez of the problem, agreeing with the latter the actions to be taken. Photos of the damage will also need to be taken.

Lifting

Lifting should preferably be carried out with a lift truck. Use a spreader beam if belts or ropes are used for slinging, making sure that there is no pressure on the upper edges of the units or the packaging.

Example of lifting with a lift truck: - Insert protection for the outer structure of the unit, for example a sheet of cardboard or polystyrene (A). - Make sure that the forks of the lift truck project at least 100 mm (4 inches) (B) from the other side of the unit.

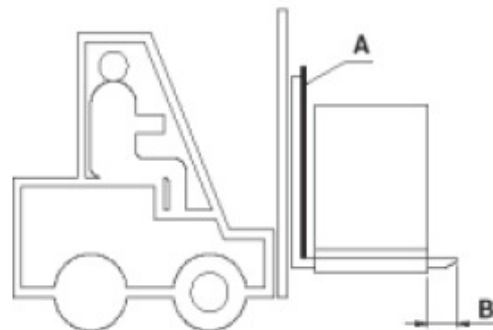

Installation (cont.)

Example of lifting with straps:

Place the lifting pipes like the figure.

Place rigid structures on the upper edges of the unit so as to ensure it is not damaged (only in the case of one point at which the force acts).

Tighten the hoisting straps gradually, ensuring that they are correctly positioned.

Begin hoisting the unit.

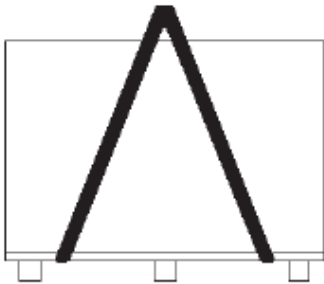

Cautions\Checks Unloading

All Models

Care must be taken when uncrating the unit to avoid damage to the equipment.

Before operation, inspect the area and remove all magnetic material within the vicinity of the magnet.

Ensure the main frame is visibly square and is not twisted.

General

When unpacking, take care to avoid damage to the equipment and possible personal injury - *the magnet assembly is very powerful and permanently charged*. Remove loose ferrous material closer than 600 mm (24 inches) to the magnet box. Spanners and other tools within the vicinity where the equipment is to be installed could become magnetically induced and be attracted to the magnet box with considerable force.

Also, when installing Suspended Permanent Magnetic Separators, check that the unit is in the correct orientation, with the heavy steel end poles at right angles to the direction of material flow.

WARNING

Electric drives must be fitted with appropriate overload protection.



Typical Installation (chains not included)

Magnet Position

The preferred installation of a suspended magnet is over the trajectory of the product material where it discharges from the belt conveyor. This position is referred to as Position 1, (Figures 1 and 2). For optimum separation in Position 1, there must be provision to adjust the location of the magnet in relation to the material trajectory. The centre of the magnet must be over the head pulley to ensure optimum performance.

A separator mounted over a moving bed of material at right angles to the conveyor is referred to as Position 2 (Figures 3 and 4). This installation usually requires a stronger magnet than Position 1 since tramp iron at the bottom of the burden is more difficult to extract.

Manual Cleaning Position 1 (In line)

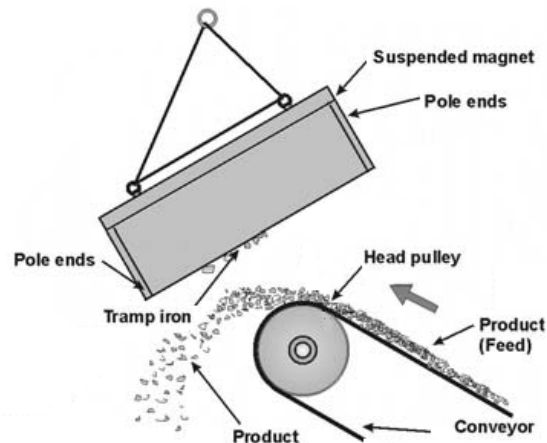

FIGURE 1

The installation of a magnetic head pulley below the magnet will significantly reduce the separation performance of the magnet.

! WARNING
A non-magnetic head pulley should be installed, regardless of the speed of the conveyor.

Self-Cleaning Position 1 (In line)

When installing a self-cleaning unit, examine the area to ensure there is adequate clearance for the belt to run and that provision has been made to collect discharged tramp iron. A hinged non-magnetic splitter, adjustable in length, will be required to prevent extracted tramp from re-entering the non-magnetics.

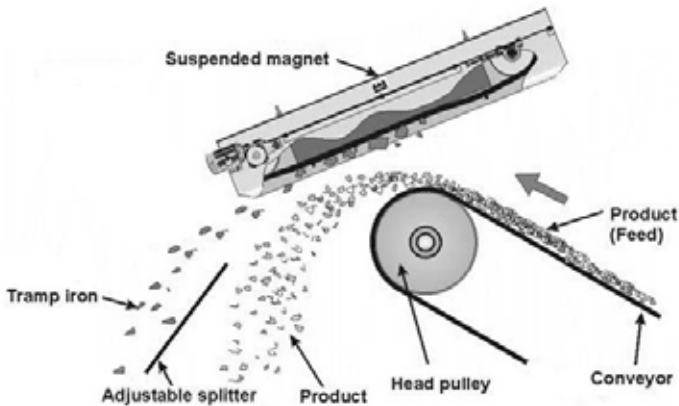

FIGURE 2

A self-cleaning magnet in position 1 may require an extension magnet to ensure that material is not discharged prematurely back in to the product flow.

Position 2 (Cross Belt installation)

A separator mounted over a moving bed of material at right angles to the conveyor is referred to as Position 2 (Figs. 3 and 4). This installation usually requires a stronger magnet than Position 1 since tramp iron at the bottom of the burden is more difficult to extract.

- The efficiency of magnetic separators in Position 2 is dependent on many factors including the speed of the conveyor carrying the feed. As conveyor speed increases above 100m/min (328 fpm), separation efficiency may fall.
- Conveyor idlers beneath the separator in Position 2 must be non-magnetic.
- Manually cleaning suspended magnets should be installed on the centreline of the material conveyor, Figure 3. Self-cleaning suspended magnets should be installed with the trailing edge of the magnet box immediately above the outer edge of the conveyor idler on the non-discharge side. Refer to Figure 4.

Self-cleaning cross belt magnets must be installed parallel to the belt at the same angle as the conveyor but at a maximum inclination of 25 degrees. The SC2 position.

Manual Clean Position 2 (Cross Belt)

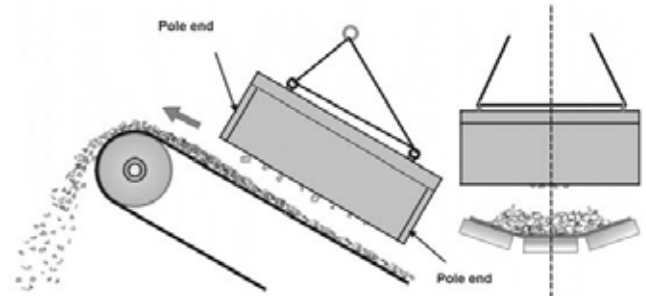

FIGURE 3

Self-Clean Position 2 (Cross Belt)

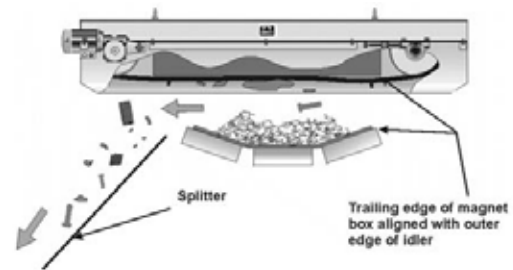

FIGURE 4

Suspension Height

The magnetic strength and configuration of a Suspended Permanent Magnetic Separator is selected for a specific suspension height and application. The suspension height quoted should be considered a maximum. The suspension height is measured from the face of the magnet block to the bottom point of the customer's feed conveyor belt.

When setting the suspension height, Figure 5, lower the magnet as close as possible to the top of the burden, without interfering with the material flow.

If the unit is self-cleaning, ensure that the separator belt is clear to operate freely while carrying tramp iron. Failing to do this could result in tramp iron being knocked back into the non-magnetics.

A clearance of 75 mm (3 inches) between the belt and the top of the product burden or trajectory should be maintained for self-cleaning units; this clearance can be reduced to 50 mm (2 inches) for manually cleaned units.



Installation (cont.)

WARNING

Do not over-tighten the self-cleaning belt as this could put excess strain and cause damage to the bearings and / or the pulleys. The equipment is designed to operate with belt sag of approximately 25 mm (1 inch).

Suspension Height Self-Cleaning – Position 2

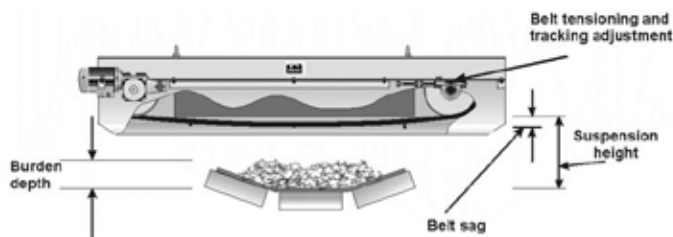

FIGURE 5

Burden Depth

One factor in achieving optimum separator performance is to control the burden depth.

- Position 1 installation. The installation location is calculated on product throughput. Any variation from this will change the trajectory of the product material with respect to the working surface of the magnet and could result in poor separation.
- Position 2 installation. A plough or leveller installed before the magnet will remove high spots or surges in material flow.

Emergency Off Push Button

Machines that require an emergency stop are fitted with a dual channel emergency off push button so as to conform to the requirements of the machinery directive.

The emergency off is for incorporation into either the customer's main safety system, or, if Eriez have supplied the controls, it will be wired back to the Eriez control box to form part of the machinery safety system. This can then be linked to the customer's safety system.

If the control system is supplied by the customer, then it is the scope and responsibility of the customer/installer to ensure an appropriate emergency stop system is utilized before powering the machine.

Lighting

Lighting is not provided with the product. This manual indicates that proper illumination is required to safely operate the machine. There are no special lighting requirements to operate or maintain the machine. Normal illumination found in factories or workshops is sufficient.

Commissioning

WARNING

Note: The first thing to be checked before any movements of the machine is the emergency off and guard switches, until you are satisfied these switches are fully operational do not proceed with the commissioning.

Note: If required, Eriez is able to provide an engineer to check the controls and adjustments before start-up.

Self-Cleaning Separators

After installation, examine for any obvious visual damage; in particular check that the frame is square and has not been twisted.

Always test the safety system before anything else. Always make sure that you are in complete control of the equipment, so with this type of machine, prove the emergency off removes all supplies to the motors etc.

Momentarily close the power supply switch to the belt drive and check that the belt is tracking properly and is not wandering laterally. *Never start the belt drive and allow it to run continuously until the belt is properly tracked.* If the belt moves to one side or the other, note the direction and adjust as follows:

- Self-cleaning magnet belts run on two or three pulleys, one fixed and the other adjustable. The adjustable tail pulley has approximately 4 inches of take up available for both belt stretch and tracking. To track the belt, the tail pulley should be adjusted to tighten the belt on the same side to which the belt is seen to move towards.
- Ensure the belt direction is correct, as incorrect operation of the belt would negate any warranty.
- Extreme care should be taken.



Belt Direction

After installing the separator, momentarily close the belt drive switch and establish that the belt direction is correct. If direction is incorrect, interchange two phases of the 3-phase supply. Correct direction is when the belt travels along the face of the magnet TOWARDS the drive pulley.

Belt Tension

The TP magnetic separators utilize a two-pulley or three-pulley design. The tail pulley has approximately 100mm (4 inches) of take-up available for belt stretch and tracking adjustment. To set the tension on the belt the screws either side of the pulley should be adjusted evenly until the desired slack in the belt is achieved, 25mm to 50mm (1 inch to 2 inches).

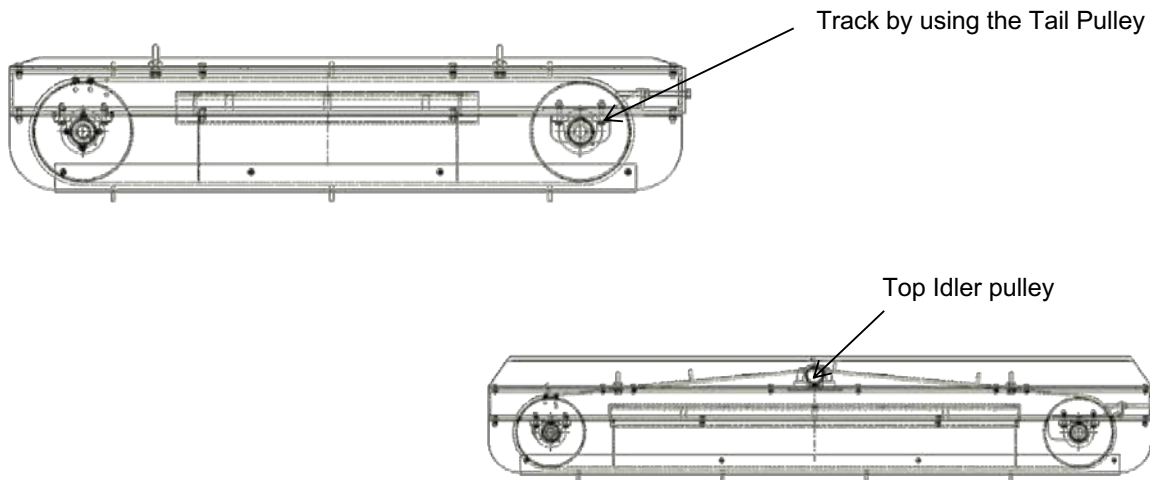

Belt Tracking

The belt is tracked at Eriez' site with the separator in the Horizontal position to check that the unit runs smoothly and working correctly.

Great care should be taken when switching the belt on for the first time, first visually inspect the belt for alignment/tracking and adjust as necessary. Be ready to switch off immediately should it suddenly wander to one side at the initial switch on.

Note - An aid to tracking can be to draw a chalk line on the outer diameter of the belt pulley

! WARNING

Never start the belt drive and allow it to run continuously until it has been fully tracked.

Commissioning (cont.)

Tracking and Adjustment Procedure

- Switch on the belt drive motor and establish if the belt is running centrally on the pulleys
- If the belt is seen to wander to one side, switch the motor off and proceed as follows
- To adjust the tracking, determine what direction the belt needs to move to track centrally, slacken the bearing holding bolts where necessary and adjust the nuts, 1/8 turn increments, on the take up plate assembly to move the tail pulley,
- Once the belt seems to be tracking correctly tighten all fittings loosened earlier and allow belt to run, if belt moves, repeat above steps until it sits centrally to the pulleys.

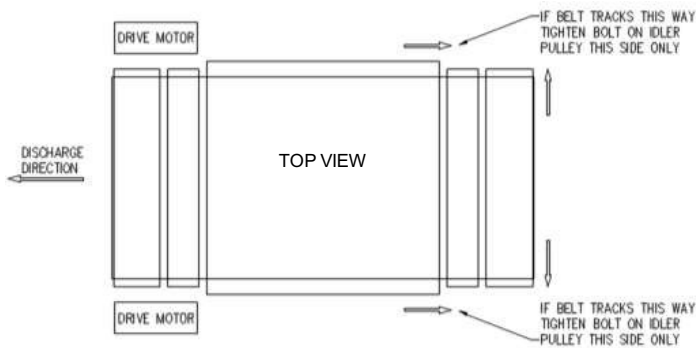

FIGURE 6
Typical Belt Adjuster

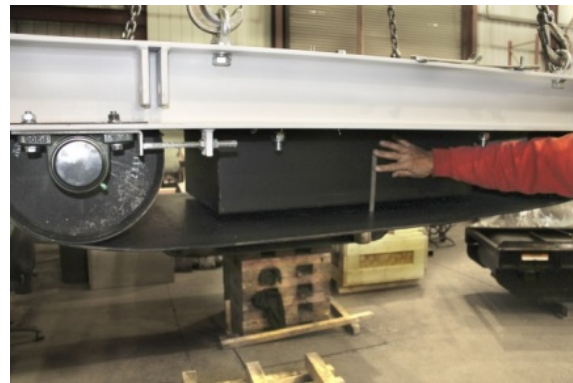

FIGURE 7
Typical Measuring Position

! WARNING

The belt is designed to operate with a belt sag of 25mm (1 inch), over-tightening of the belt will cause damage to the bearings, couplings and/or pulleys and invalidate the warranty.



FIGURE 8
Typical Belt Sag 25mm (1 inch)

Preventative Maintenance

Routine Maintenance

WARNING

Before carrying out any maintenance on the Separator, refer to “General Health and Safety/ Warning Notices” and “General Risk and Hazard Assessment”, in this manual. All maintenance personnel must be suitably trained and passed as competent. All personnel should be made aware of the location and operation of the Emergency Stop button.

WARNING

Before carrying out any maintenance, ensure that the Separator is rendered safe, with services switched off and isolated, prior to commencing maintenance tasks.

WARNING

Permanent Magnets are Permanent! The magnet will be ‘live’ even with all power isolated. Extreme care must be taken at all times.

Note: Normal maintenance does not require the customer or user to gain access inside the Separator’s Magnet Enclosure.

Daily

- Check for unusual operating noises.
- Check that the dust level isn’t excessive.
- Remove any trapped tramp iron (protective gloves required).

Weekly

- Check the level of dust deposited and clean to an acceptable level to ensure that no overheating occurs.
- Remove any trapped tramp iron (protective gloves required).
- Check for signs of wear or impact on the face of the magnet (Manual Clean only).

Monthly

- Remove any trapped tramp iron (protective gloves required).
- Check belt for wear, tracking, and tension.

Quarterly

- Lubricate bearings, refer to section “Bearing Relubrication”. DO NOT over grease.

Yearly

- An annual full service by a qualified engineer is recommended.
- If an electric drive is fitted, check the oil level in gearbox and refill as necessary.
- If a hydraulic drive is fitted, check fittings and seals for leaks, no other maintenance is necessary under normal conditions.

General Safety Rule

Before carrying out inspections, maintenance and controls, scrupulously comply with all that is listed below:

- Check that the power on/off switch is put to off and padlocked. If the company is running a tag out system, ensure that you get your name added to the list of workers ensuring no-one can put power back on without your signature.
- Check that there are no moving parts powered from auxiliary supplies.
- Check for potential hazards from other items of equipment being started.
- Observe the accident-prevention regulations.
- Put on adequate personal protective equipment (gloves, goggles, etc.)
- Except for visual inspections, all the operations are to be carried out solely by specialized and expert personnel; otherwise the warranty is rendered invalid.

Manual Cleaning Separators

No maintenance is required.

Preventative Maintenance (cont.)

Self-Cleaning Separators

- Belt tracking should be checked frequently and adjusted as necessary. Refer to “Commissioning”
- Lubricate the bearings on a schedule consistent with other equipment in use at the site for the product and environment. At least quarterly as per the preventative maintenance schedule.
- If the unit is installed within a separate enclosure, provision must be made to the construction of the enclosure to gain easy access to moving parts.
- Check the self-cleaning belt for damage and, if necessary, replace as follows:

Vulcanized Belt

Replacing a vulcanized belt requires the self-cleaning gear to be dismantled after the separator has been removed from its installation. This is a major operation and is not always practical. An alternative method is to replace the belt and vulcanize on site.

- Slacken the bolts securing the non-drive pulley.
- Slacken the belt tensioning screws.
- Cut through the damaged belt and remove it.
- Wrap the new belt and vulcanize.
- Re-tension the belt; allowing for belt sag; refer to “Commissioning”

Laced Belt

To replace a laced belt proceed as follows:

- Slacken the bolts securing the non-drive pulley.
- Slacken the belt tensioning screws.
- Remove the braided stainless steel wire.
- Re-tension the belt, allowing for belt sag; refer to “Commissioning”
- Re-track; refer to “Commissioning”.
- Tighten the bearing securing bolts.

Bearing Relubrication

Relubrication of the bearings is not normally necessary except when operating at extreme temperatures, speed and loading, or where excessive wet or dirty conditions exist. The relubrication frequency varies with the type and quality of grease used as well as the operating conditions; therefore it is difficult to establish a general rule.

The performance of a bearing is greatly influenced by the quantity of grease. In order to avoid overfilling, it is advisable to replenish the grease while the machine is in operation. Use only Shell Alvania S2 grease or equivalent.

- There are 4 bearings per separator as indicated in Figure 9.
- To prevent damage to seals only manual grease pumps should be used. DO NOT use pressurized pumps or automated greasing systems.
- Remove bearing protector caps, if fitted, so that the bearing inserts can be observed.
- Attach grease pump to nipple on first bearing as indicated in Figure 10.
- Continue to insert grease until a little oozes out from beneath the sealing lip on the inner ring for optimum performance
- Repeat process for the remaining 3 bearings.
- Re-fit protector caps if applicable.

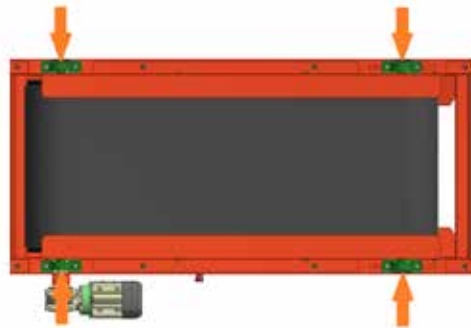

FIGURE 9

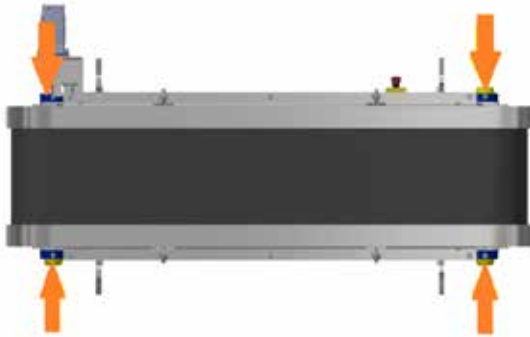

FIGURE 10

Drive Coupling Alignment (Hydraulic Motor)

It is essential that the drive coupling fitted to the hydraulic drive models is correctly aligned to prevent damage and failure of the coupling. Both coupling halves are designed to fit together in one position only due to one half close fitting into a recess in the other half. A locating pin between both coupling half faces further ensures alignment. The hydraulic motors are mounted on a support bracket and are fixed in position with bolts and dowels.

Note: Over-tensioning of the belt or impact to the drive pulley can cause misalignment.



Recess to help assembly of both coupling halves

Locating Pin



Ensure nuts & bolts are tight

Joint between coupling halves



FIGURE 11

Troubleshooting & Recommended Spares

Manual-Cleaning Units

Problem	Probable Cause	Solution
Magnet will not attract iron	Magnet face is overloaded with extracted iron.	Examine the face of the magnet for excessive quantities of extracted tramp iron. Discharge more frequently as required.
	Magnet set too far from the burden.	Check the clearance between the magnet face and the burden. Refer to SUSPENSION HEIGHT and set accordingly.
	Magnet set too close to the burden.	If the magnet is set too close, material surges can act as a wiper and remove iron from the magnet surface. Check clearance and adjust. Refer to SUSPENSION HEIGHT.

Self-Cleaning Units

Problem	Probable Cause	Solution
Tramp iron entering the product	Not sufficient clearance for the iron to be discharged.	Position 2 installation: Check the clearance between the bottom of the magnet box and the edge of the conveyor belt for maximum iron size to clear. Adjust as necessary.
	Splitter improperly positioned.	Position 1 installations: Adjust the splitter angle and length to suit.

Note: Recommend a spare belt and motor be kept on hand to minimize downtime.



Disposal of System

Dispose of the unit according to local, national and international guidelines.

Gear Units

Dispose gear units in accordance with regulations in force regarding respective materials

- Steel Scrap
- Housing Parts
- Gears
- Shafts
- Roller bearing
- Parts of the worm gears are made of non-ferrous metals. Dispose of the worm gears as appropriate.
- Collect waste oil and dispose of it according to the regulations in force.

Motor Units

Dispose of the Motors in accordance with regulations in force regarding respective materials.

- Iron
- Aluminium
- Copper
- Plastic
- Electronic Components
- Oil and Grease (not mixed with solvents)

Magnet

Dispose of all equipment and packaging according to applicable local, regional, national and international regulations.

Eriez and Eriez Magnetics are registered trademarks of Eriez Manufacturing Co, Erie, PA

©2020 Eriez All Rights Reserved



World Authority in Separation Technologies

Headquarters: 2200 Asbury Road, Erie, PA 16506-1402 U.S.A.

Telephone: 814-835-6000 • Fax: 814-838-4960

www.eriez.com e-mail: eriez@eriez.com



Manufacturing Facilities: AUSTRALIA • BRAZIL • CANADA • CHINA • INDIA • JAPAN • MEXICO • SOUTH AFRICA • UNITED KINGDOM • UNITED STATES