

Installation, Operation and Maintenance Instructions



**COOLANT
CLEANERS
MODELS CE,
CS, IE & IS**

ERIEZ MAGNETICS HEADQUARTERS: 2200 ASBURY ROAD, P.O. BOX 10608, ERIE, PA 16514-0608 U.S.A.
WORLD AUTHORITY IN ADVANCED TECHNOLOGY FOR MAGNETIC, VIBRATORY and INSPECTION APPLICATIONS

Introduction

This manual describes a compact and efficient machine for removing magnetic contamination from coolant fluids.

A careful reading of these Installation, Operation and Maintenance Instructions will assure the most efficient and dependable performance.

If there are any questions or comments about the manual, please call the Eriez Manufacturing at 814/835-6000 for assistance.



CAUTION - STRONG MAGNET

This equipment includes one or more extremely powerful magnetic circuits. The magnetic field may be much stronger than the Earth's background field at a distance several times the largest dimension of the equipment.

- **If you use a heart pacemaker or similar device you must never approach the equipment because your device may malfunction in the magnetic field, with consequences up to and including death.**
- **To avoid serious pinch-type injuries caused by objects attracted to the magnet, keep all steel and iron objects well away from the equipment. Do not allow hands, fingers, and other body parts to be caught between the equipment and nearby steel or iron objects.**
- **Keep credit cards, computer disks, and other magnetic storage devices away from the equipment because magnetically stored information may be corrupted by the magnetic field.**
- **Keep electronic devices, such as computers or monitors, away from the equipment because exposure to the magnetic field may result in malfunction or permanent damage to such devices.**

Contact Eriez if you have a question regarding these precautions.



CAUTION

Safety labels must be affixed to this product. Should the safety label(s) be damaged, dislodged or removed, contact Eriez for replacement.

Table of Contents

COOLANT CLEANERS - MODELS CE, CS, IE & IS

INSTALLATION	5
Damage in Shipment	5
Handling	5
Installation Procedure.....	5
General	5
Changing Motor Mounting.....	5
Changing Level Switch Mounting.....	6
Wiring.....	6
ADJUSTMENTS	8
Baffle	8
Gap Bar	8
Scraper Blades.....	8
Scraper Mounting Angle.....	8
Level Switch	9
Indexing Control	9
OPERATION	9
Models CE and CS.....	9
Models IE and IS	9
Capacities.....	10
Materials Handled	10
MAINTENANCE	11
Lubrication.....	11
General	11
PARTS LIST	11

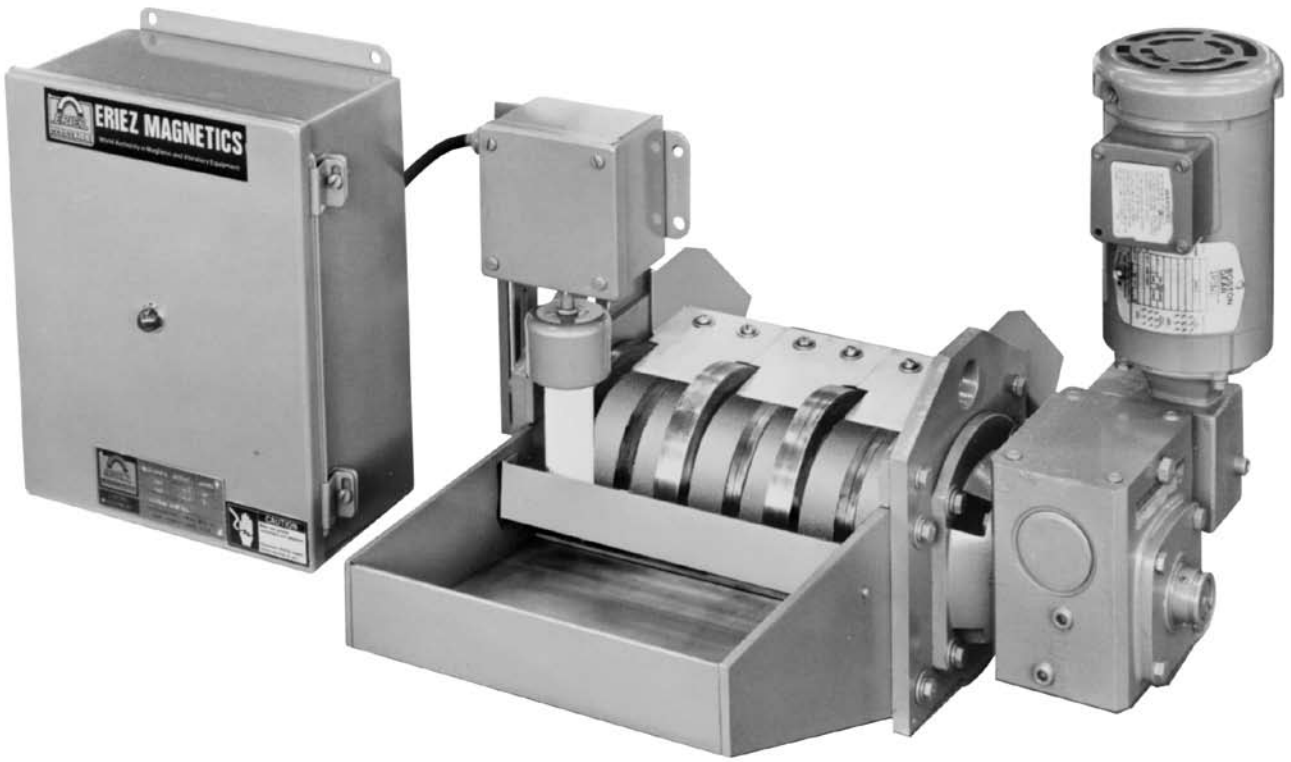

TYPICAL MODEL IE COOLANT CLEANER WITH CONTROL



TYPICAL MODEL CS COOLANT CLEANER

Installation

DAMAGE IN SHIPMENT

When you receive your Coolant Cleaner, examine it carefully for damage. If any is found, report it immediately to the carrier.

Be sure that there is no object in the gap between the magnetic roll and housing.

HANDLING

Lift eyes are provided on all models. Care should be taken not to damage any parts when moving the unit.



CAUTION - ROTATING MACHINERY

As with all equipment involving rotating parts the potential for property damage or serious personal injury if not treated with caution during all installation and maintenance procedures. Equipment should be switched off and locked out during all procedures that involve contact with the machine. Avoid pinch points between scraper blades and roll along with roll to housing!

INSTALLATION PROCEDURE

The Coolant Cleaner should be mounted level. Tapped holes are provided in the bottom edges for securing the unit if desired.

The clean coolant outlet in the bottom of the unit should be positioned over a tank or sump and a catch pan should be set under the iron discharge chute.

Do not immerse the drive in liquid. The dirty coolant should be introduced into the inlet hopper from a trough centered over the hopper. Unless the volume is very small, feeding the coolant from a pipe produces excessive splashing and turbulence.

CHANGING THE MOTOR MOUNTING

If the installation requires, the gearmotor may be mounted on the opposite side of the housing (see Figures 1 and 2).

1. Remove scraper assembly bolts "A"
2. Remove side plate bolts "B"
3. Loosen bearing set screws "C"
4. Lift out entire roll and drive assembly from housing using the lift eyes.
5. Clean old sealant from side plates and housing.
6. Apply a fresh coat of sealant, such as R.T.V. or gasket compound, to housing.
7. Set roll and drive assembly back into the housing the way desired.
8. Replace side plate bolts "B"
9. Tighten bearing set screws "C"
10. Replace scraper assembly
11. Check to see if scraper blades contact the roll but exert only light pressure (See Scraper Adjustment).

The gearmotor may be rotated about the drive shaft in 90° increments. Proceed as follows:

1. Remove the mounting bolts in the flange
2. Rotate the gearbox until the holes in the flange line up with the next set of holes in the side plate.
3. Replace the mounting bolts.
4. Move the breather plug in the gearbox to the highest position.

Installation (cont.)

CHANGING THE LEVEL SWITCH MOUNTING (On Indexing Models Only)

The level switch can be mounted on the opposite side (see Fig. 2):

1. Remove bolts "E"
2. Remove switch
3. Remove bolts "F" both sides
4. Remount bracket on the other side using the opposite slot
5. Remount switch with bolts "E"

WIRING

Models CE and CS are to be wired directly to the motor from a fused disconnect or protected service. Standard units are to be wired for 230 volts or 460 volts, 3 phase, 60 cycle. Connect so that roll rotates against scraper blade (see Figures 3 and 5).

Models IE and IS are to be wired in the following manner (see Figure 3):

1. Check nameplate on control box for supply requirements.
2. Check motor to be sure that it is connected for the right voltage.
3. Connect input lines L1, L2 and L3 from either a fused disconnect or protected service.
4. Connect leads from the motors to T1, T2 and T3.
5. Connect pressure switch lines to terminals 1 and 2.

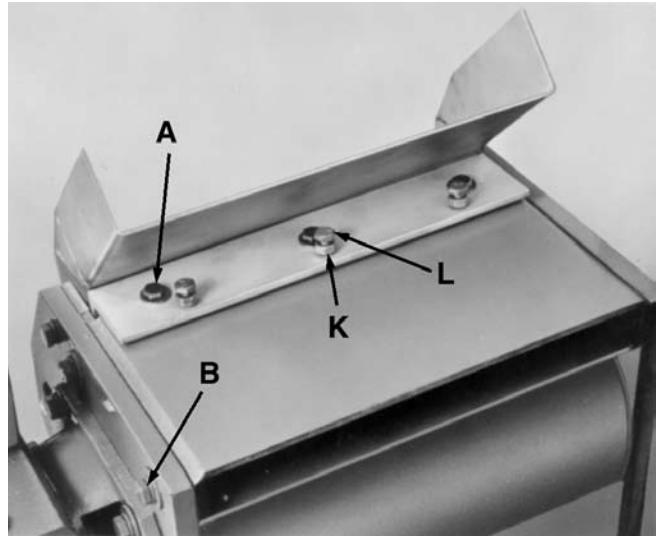

FIGURE 1

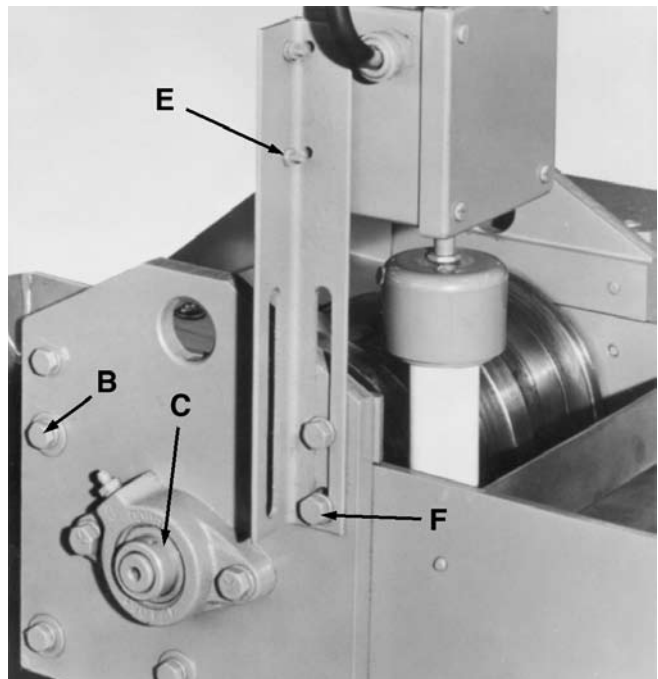

FIGURE 2

Installation (cont.)

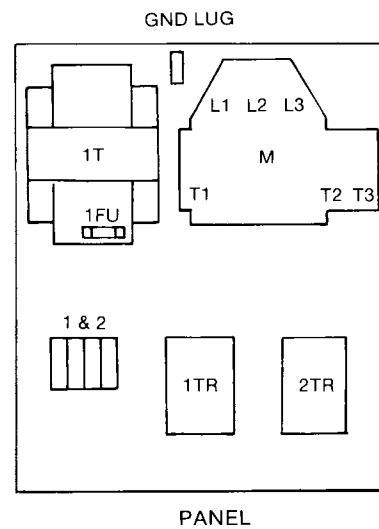
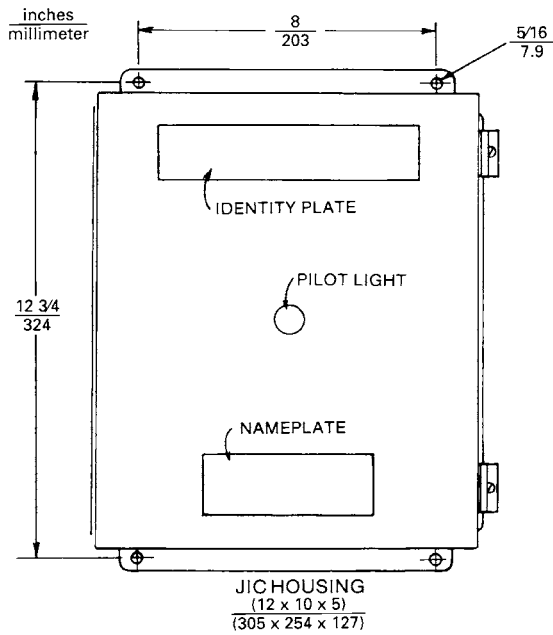
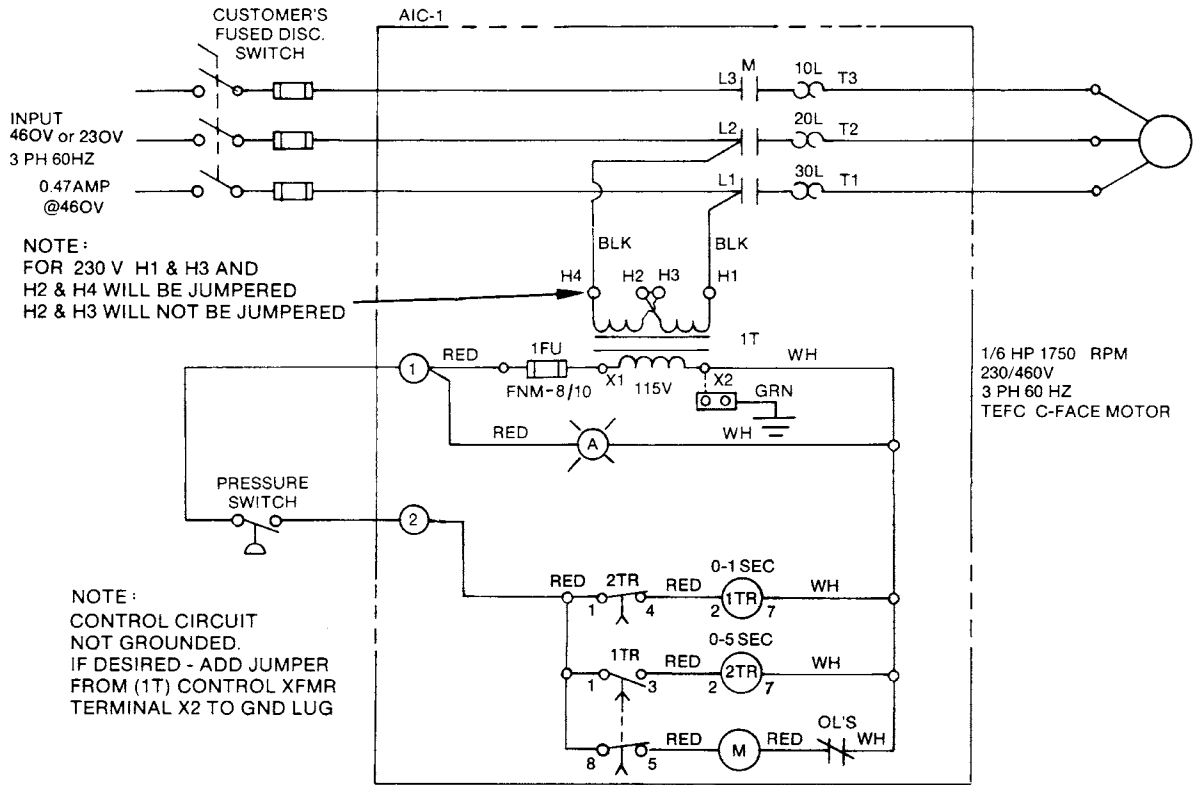

FIGURE 3

Adjustments

BAFFLE

The baffle should be adjusted so that the flow from the inlet hopper to the magnetic roll is spread evenly with minimal turbulence.

To adjust (see Figure 4):

1. Loosen bolts "G"
2. Slide baffle up or down
3. Tighten bolts "G"

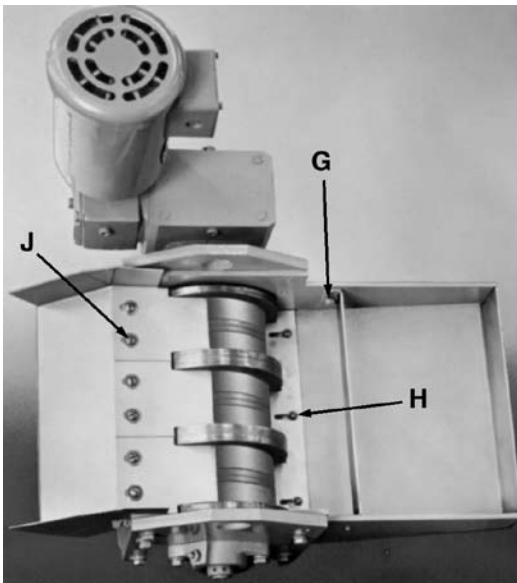

FIGURE 4

GAP BAR

The gap bar should be set as close to the magnetic roll as possible and still allow all the coolant being circulated to pass through.

To adjust (see Figure 4):

1. Loosen round head screws "H"
2. Slide the gap bar back or forward
3. Tighten the round head screws "H"

SCRAPER BLADES

The scraper blades should exert only light pressure on the magnetic roll.

To adjust (see Figure 4):

1. Loosen round head screws "J"
2. Slide blades forward until they touch the roll
3. Tighten screws

SCRAPER MOUNTING ANGLE

The scraper blades are normally set at 2-5° down. To increase the angle (see Figure 1):

1. Loosen bolts "A"
2. Loosen locknuts "K"
3. Tighten bolts "L"
4. Tighten locknuts "K"

To decrease the angle:

1. Loosen locknuts "K"
2. Loosen bolts "L"
3. Tighten bolts "A"
4. Tighten locknuts "K"

After adjusting the angle, check the scraper blades and adjust if necessary. Be sure that the blades are not binding the roll. Check the current reading of the motor against the nameplate rating to see if there is any binding.

Adjustments (cont.)

ON INDEXING MODELS ONLY: LEVEL SWITCH

The level switch height should be set so that normal flow does not touch the dip tube. Normally 1/2-inch to 3/4-inch (13 mm to 19 mm) gap between the bottom of the dip tube and the housing is satisfactory.

To adjust the switch (see Figure 2):

1. Loosen bolts "F"
2. Slide bracket up or down
3. Tighten bolts "F"

INDEXING CONTROL

Located inside the control box are two timers (refer to Wiring Diagram, Figure 3).

Timer (1TR) adjusts amount of rotation the roll indexes. Heavier swarf loads generally require

a longer index.

Timer (2TR) adjusts pause or duration between indexes. This allows liquid level to stabilize before next roll rotation.

For optimum filtration efficiency, adjust timers for the smallest amount of indexing with the longest pause between indexes without the Coolant Cleaner overflowing.

NOTE: Allow some margin of safety to prevent possible overflow.

Initial settings for start up are:

Timer (1TR) set at 0.3 seconds

Timer (2TR) set at 5.0 seconds

Operation

MODELS CE AND CS

The coolant fluid is fed into the inlet and flows down and through a narrow gap between the magnetic roll and housing. The continuously rotating roll separates the magnetic material and carries it out of the flow. When the magnetic material reaches the top of the roll, it is removed by an adjustable scraper and is discharged down a small chute. The cleaned coolant is discharged through an opening in the bottom of the unit.

An adjustable baffle in the inlet distributes the coolant across the face of the magnetic roll and minimizes turbulence.

An adjustable gap bar between the roll and the housing allows the unit to be fine-tuned for a variety of conditions. See the Adjustment section for complete instructions.

MODELS IE AND IS

These models operate on the same basic principle as Models CE and CS except instead of rotating the magnetic roll continuously, the roll moves only as required to maintain coolant flow.

In operation, the roll is stopped while a plug of magnetic material builds up between the roll and housing. Non-magnetic particles also become trapped in this "filter plug." When the plug becomes dense enough to restrict the coolant flow, the coolant level rises in the inlet hopper. This activates a low pressure type level sensing switch which causes the roll to rotate slightly and restores the coolant flow. This process repeats itself as often as required.

Operation (cont.)

INDEXING CONTROL

The automatic index control AIC-1 controls the intermittent rotation or “indexing” of the magnetic roll. It consists of a motor starter along with a timing circuit. One adjustable timer determines the amount of rotation of the roll and another adjustable timer determines the time period between indexes. A liquid level sensor in the cleaner’s inlet hopper monitors the coolant level and activates the timing circuits. By adjusting these timers, you can regulate the density of the filter media on the magnetic roll. See the Adjustment section for complete instructions.

CAPACITIES

Table 1 and 2 below show the maximum capacity for standard units under ideal conditions.

When conditions are less than ideal, such as thicker coolants, large percentage of solids, or weakly magnetic contamination, the capacities must be reduced.

**Table 1. Maximum Flow Rates*
Models CS5, CE5, IS5, and IE5**

MODEL	COOLANT TYPE					
	WATER SOLUBLE		OIL-40 SSU		OIL-100 SSU	
	GPM	LPM	GPM	LPM	GPM	LPM
CS5-7	22	83	15	57	11	42
CS5-10	36	136	24	91	18	68
CS5-13	47	178	30	114	25	95
CS5-20	73	276	45	170	36	136
CS5-27	98	371	61	231	48	182
CE5-7	17	64	9	34	7	27
CE5-10	22	83	13	49	10	38
CE5-13	29	110	19	72	13	49
CE5-20	43	163	27	102	19	72
CE5-27	57	216	37	140	25	95
IS5-7	16	61	9	34	7	27
IS5-10	21	80	13	49	9	34
IS5-13	28	106	18	68	12	45
IS5-20	42	159	26	98	19	72
IS5-27	56	212	36	136	24	91
IE5-7	12	45	8	30	7	27
IE5-10	17	64	11	42	10	38
IE5-13	22	83	14	53	13	49
IE5-20	33	125	22	83	19	72
IE5-27	44	167	29	110	25	95

**Table 1. Maximum Flow Rates*
Models CS8, CE8, IS8, and IE8**

MODEL	COOLANT TYPE					
	WATER SOLUBLE		OIL-40 SSU		OIL-100 SSU	
	GPM	LPM	GPM	LPM	GPM	LPM
CS8-21	180	681	85	322	70	265
CS8-35	300	1135	140	530	115	435
CS8-49	420	1590	200	757	165	625
CS8-70	600	2271	285	1079	235	890
CE8-21	110	416	50	189	40	151
CE8-35	180	681	85	322	70	265
CE8-49	250	946	120	454	100	379
CE8-70	360	1363	170	643	140	530
IS8-21	120	454	60	227	50	189
IS8-35	205	776	95	360	80	303
IS8-49	290	1098	135	511	110	415
IS8-70	410	1552	195	738	160	606
IE8-21	85	322	40	151	35	133
IE8-35	140	530	65	246	55	208
IE8-49	195	738	90	341	75	284
IE8-70	280	1060	130	492	110	416

*Rates shown are based on physical capacity. Lower rates may be required depending upon turbulence, amount of contaminants present and the degree of separation desired.

MATERIAL HANDLED

Eriez Coolant Cleaners are designed to remove fine magnetic contamination from light coolant fluids. Some non-magnetic particles can be removed by the indexing models provided that magnetic particles are also present.

Use with heavier fluids or particles larger than 1/4-inch (6 mm) across is not recommended.

The standard unit should not be used with highly corrosive fluids or with solvents which would affect the neoprene shaft seals.

Maintenance

The one shaft bearing should be lubricated at regular intervals ranging from weekly to monthly depending on operating conditions.

The lubricant level in the gear box should be checked periodically and added to when needed. Refer to manufacturer's instructions for proper filling. A copy of the instructions is supplied with your unit.

GENERAL

The scraper blade should be checked occasionally to insure proper operation. If it becomes worn, adjust as outlined in the Adjustment section.

If an excessive amount of material collects in the inlet hopper, either relocate the inlet coolant feed or periodically clean the hopper.

If the unit is not operated for an extended period of time, flush it out with clean coolant and remove any material from the scraper blade to prevent damage especially to the gearmotor from the material drying out and hardening.

Parts List

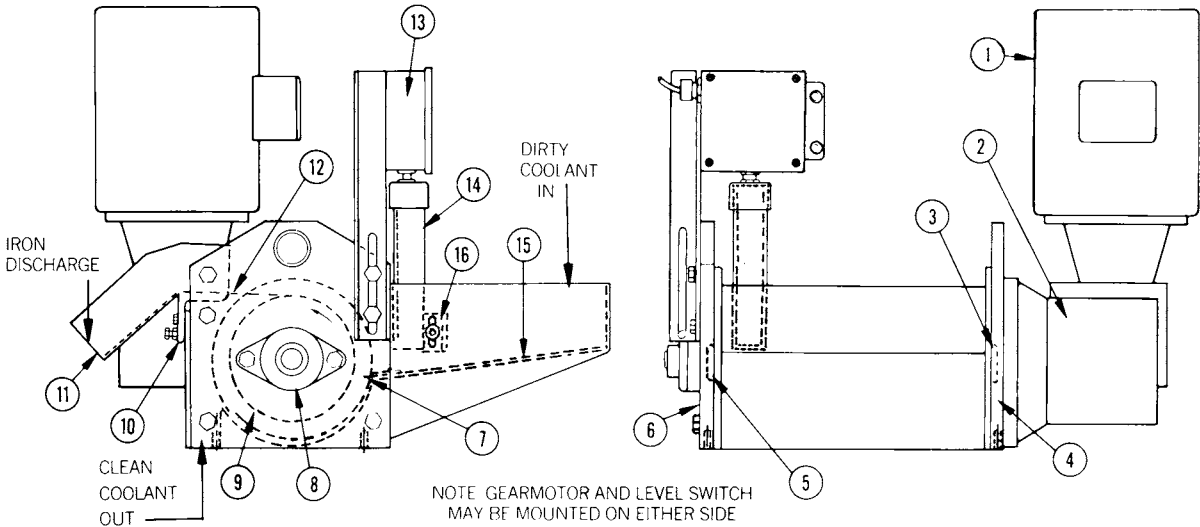

- | | | |
|--------------------------|------------------|--|
| ① Drive Motor | ⑦ Gap Bar | ⑬ Low Pressure Type Level Switch (Models IE & IS only) |
| ② Gear Reducer | ⑧ Bearing | ⑭ Dip Tube - (Models IE & IS only) |
| ③ Drive End Shaft Seal | ⑨ Magnetic Roll | ⑮ Housing |
| ④ Drive End Plate | ⑩ Scraper Angle | ⑯ Baffle |
| ⑤ Bearing End Shaft Seal | ⑪ Scraper Chute | |
| ⑥ Bearing End Plate | ⑫ Scraper Blades | |



World Authority in Advanced Technology for Magnetic, Vibratory and Inspection Applications

HEADQUARTERS: 2200 ASBURY ROAD, P.O. BOX 10608, ERIE, PA 16514-0608 U.S.A.

Telephone 814/835-6000 • 800/345-4946 • Fax 814/838-4960 • International Fax 814/833-3348

Web Site: <http://www.eriez.com>

e-mail: eriez@eriez.com

MANUFACTURING FACILITIES IN: UNITED STATES • AUSTRALIA • BRAZIL • CANADA • CHINA • INDIA • JAPAN • MEXICO • SOUTH AFRICA • UNITED KINGDOM