

Installation, Operation and Maintenance Instructions



METAL DETECTOR MODEL 1230 DIGITAL

ERIEZ MAGNETICS HEADQUARTERS: 2200 ASBURY ROAD, ERIE, PA 16506-1402 U.S.A.
WORLD AUTHORITY IN SEPARATION TECHNOLOGIES

Introduction

This manual details the proper steps for installing, operating and maintaining the Eriez Metal Detector Model 1230.

Careful attention to these requirements will assure the most efficient and dependable performance of this equipment.

If there are any questions or comments about the manual, please call Eriez at 814-835-6000 for Model 1230 Metal Detector assistance.

 **CAUTION**

**Safety labels must be affixed to this product.
Should the safety label(s) be damaged, dislodged
or removed, contact Eriez for replacement.**

Table of Contents

ERIEZ METAL DETECTOR MODEL 1230

SAFETY WARNINGS	5
General	5
Installation	5
Connections	5
Long Term Storage.....	5
GENERAL INFORMATION.....	5
Standard Warranty	5
Installation Assistance.....	5
Technical/Application Assistance	5
DESCRIPTION	6
General	6
Method of Operation	6
Safety	6
Electronic Enclosure	7
Dimensions.....	7
Technical Data	8
Electronic Control	8
Electronics Board	9
Signal Analyzer Board	11
Search Coil Assembly	12
Clip Detector	13
Dual Clip Detector	13
Spray Marking Device.....	14
Flag Drop Marker	14
Idler Isolation Kit	15
INSTALLATION	16
Recommended Tools	16
Unpacking	16
Site Selection & Preparation	16
Idler Roller Isolation	16
Mounting - Search Coil Assembly	18
Mounting - Main Control Enclosure.....	20
Swing-Away Switch.....	20
Clip Detector	21
Dual Clip Detector	22
Spray Marking Device.....	22
Flag Drop Marker	24
START-UP & CALIBRATION	26
Start-Up.....	26
Operation	26
Display Screens	26
Metal Sensitivity Calibration.....	27
Clip Detector Calibration	28
Dual Clip Operation.....	28
Direct and Timed Out Setup.....	29
Marking Device Calibration	29



Table of Contents *(continued)*

ERIEZ METAL DETECTOR MODEL 1230

Menu Tree (Operator Level 1).....	30
Menu Tree (Operator Level 2).....	34
Menu Tree (Operator Level 3).....	37
ERRORS AND FAULT RECTIFICATION.....	44
Error Messages.....	44
Undefined Activation of Switching Outputs	46
APPENDIX A: CONTROL CONNECTION DIAGRAMS.....	47
APPENDIX A: WIRING DIAGRAM.....	48
INPUT POWER TO THE DETECTOR	51
WIRING INCOMING POWER	51
RECEIVER PREPARATIONS	53
Receiver Cable	53
TRANSMITTER PREPARATIONS	55
Transmitter Cable.....	55
METAL DETECTED - DIRECT OUTPUT CONNECTION	56
METAL DETECTED - TIMED OUTPUT CONNECTION	57
FAULT OUTPUT.....	58
SINGLE CLIP DETECTOR CONNECTION	59
DUAL CLIP DETECTOR CONNECTION	60
24VDC SPRAY MARKER.....	61
FLAG DROP MARKER	62
24VDC PANEL MOUNT ALARM HORN AND/OR LIGHT	63
115 OR 220VAC POLE MOUNT ALARM HORN AND/OR LIGHT	65
VOLTAGE REGULATOR.....	66
SWING AWAY SWITCH CONNECTION	67
REMOTE RESET CONNECTION.....	68
SYNCHRONIZING 2 DETECTORS	69
APPENDIX B: SERVICE, PARTS, REPAIRS.....	70
REPLACING ELECTRONIC BOARDS	71
Replacing the Data Memory	72
REPLACING THE MAIN ELECTRONICS MODULE.....	73
REPLACING THE DISPLAY BOARD.....	73
SPARE PARTS, SERVICING	74
Spare Parts Drawing.....	74
Spare Parts List	74
FRAME ASSEMBLY	75



Safety Warnings

THIS DETECTOR SHOULD BE INSTALLED BY QUALIFIED ELECTRICAL AND MECHANICAL PERSONNEL ONLY.

General

- All standard safety procedures should be observed when working on electrically powered equipment.
- Proper care should be taken when connecting or disconnecting the power source.
- When connected to a power source, un-insulated, dangerous voltage is present within the Detector's electronics enclosure which may constitute a risk of electric shock.
- Do not allow moisture to collect in the electronics enclosure or near the power connections. Always close the enclosure and secure the locking mechanism after working with the electronics.
- The user should not attempt to service the Detector. All servicing should be referred to certified service personnel qualified to work on electrical equipment.

Eriez accepts no responsibility for damage due to use or misuse of this equipment.

Installation

- Do not install this Detector near heat sources such as radiators or air ducts.
- Do not install this Detector near sources of electromagnetic interference
- Place the Detector in a location with adequate air circulation to prevent internal heat buildup.

Connections

▲ As standard, this Detector is set for connection to 115 VAC or 220 VAC. Refer to Appendix A Control Connection Diagram for information about connections and color code hook-up instructions.

Long Term Storage

For long term storage, the metal detector should be left sealed inside the shipping container and stored in a dry location in temperatures between -10°C and +50°C (14° F - 122° F).

General Information

Eriez detectors are custom fabricated to suit each user's particular application. Each detector system is subjected to extensive testing both at the sub-assembly level and after final assembly to ensure compliance with performance and electrical safety standards.

Standard Warranty (Please refer to full warranty information)

Eriez new metal detectors are warranted against defects in workmanship and materials for three years. This warranty does not cover failures due to misuse, neglect, abuse, improper handling, alteration, improper maintenance or accident, and Eriez shall not be liable for any direct, indirect, consequential or incidental damages from use, results of use or inability to use this product. Repairs by any other than Eriez authorized service personnel will void this warranty.

Within the warranty period, the product will be repaired or replaced at Eriez' option, free of charge; shipping costs will be paid by Eriez. Except as mentioned above, no other warranty, expressed or implied, applies. If Modules are not covered by warranty as mentioned above, Dealer/ User will be billed for the repair and shipping. Non warranty repairs, Dealer/User must issue a PO # or Credit Card # prior to any repair.

Installation Assistance

Eriez detectors have been designed for installation by qualified personnel with detailed instructions provided with each shipment. When required, a Eriez Field Engineer will supervise or check the installation, activate the system and provide training on periodic adjustments and care of the Detector for user maintenance personnel. Please contact Eriez for Field Service rates.

Technical/Application Assistance

Eriez welcomes your inquiries concerning metal detectors and their application, installation and servicing. If technical or application assistance is needed, contact:

Eriez Magnetics

2200 Asbury Road, Erie, PA 16506-1402 USA

Phone: 814-835-6000 • 800-345-4946

Email: eriez@eriez.com

Website: www.eriez.com



Description

General

The Model 1230 provides protection to downstream processing equipment by detecting the presence of potentially damaging metal objects. It is specifically designed for use on conveyor systems carrying materials which contain consolidated or fractured magnetic or nonmagnetic ore, as well as ores ranging in electrical conductivity. The Detector will discriminate between these conveyed materials and tramp metal of any type: ferrous, nonferrous, magnetic or nonmagnetic.

The Detector makes use of the latest in digital electronic technology. The design includes a number of innovative features: self-test circuits that monitor the performance of the detection circuitry, which when they fail, will trigger a Fault Relay. Wide programming capability to custom tailor the Detector to suit specific application requirements.

Method of Operation

During normal operation, the transmitter coil is energized to produce a pulsed electromagnetic signal. These signals produce a field that locally permeates the conveyed material. This field will induce a small current in metal objects moving through the field. The induced current in the metal then induces a current in the receiver antenna. This technique provides optimum discrimination between tramp metal and the conveyed material; product effect is non-existent or minimal.

The signal from the tramp metal is amplified and filtered. The processed signal is then compared to a threshold determined by the size of metal that must be detected. When the signal exceeds this threshold, the Detector, at the appropriate time, triggers the output relays.

The Detector is influenced only by change. Therefore, stationary structural members, metal belt cords, symmetrical idlers and other objects which do not represent a moving mass to the field are not detected though they can distort the field and affect performance. Metal belt repair clips are passed by the unit with an optional clip detector sensor. Clip Mode temporarily reduces the detectors sensitivity while the clip moves through the antenna area.

Safety

As a manufacturer we believe it is our duty to make you aware of the following information.

INTENDED USE

The equipment is to be used in the following applications only with the appropriate detection coil: Conveyor belt application. The ambient temperature of the machine must not exceed -40°F to 149°F (-40°C to +65°C). Ensure that the installation area is free from steam, plasticizers or other materials that may damage the frame or enclosure.

SAFETY SIGNS

Mains voltage runs through the Eriez 1230 control unit housing and may also be connected to any external electric circuits (eg. metal relays).

Therefore, the safety sign shown above is displayed on the cover of the electronics housing.

DANGERS ARISING FROM NON-COMPLIANCE WITH SAFETY NOTICES

Life-endangering electric shocks are likely in cases of non-compliance with the safety notices.

SAFETY INFORMATION FOR OPERATORS

The Eriez 1230 control unit must be in perfect working order and used for the purpose for which it was designed, in particular, ensure that the cover of the electronic housing is closed during operation. Any moisture which penetrates the electronic housing must be removed. Safety signage must not be removed and must be maintained in good condition. The instruction manual must remain complete and in good, readable condition.

Only qualified personnel must operate, maintain and repair the equipment. People with heart pace-makers should not spend long periods near the detection coil. When inspecting materials which are likely to explode follow the appropriate regulations.

SAFETY INFORMATION FOR OPERATORS AND MAINTENANCE

Before opening the electronics housing clean the outside area to reduce the risk of dirt and moisture penetrating inside. Disconnect power supply and external circuits before opening the cover. Any moisture which penetrates the electronic housing must be removed.

Only qualified personnel should operate, maintain and repair the equipment.



NOTES ON RESIDUAL RISKS

Electrical circuits may still be live even after having been isolated from the mains.

CONSEQUENCES OF UNAUTHORIZED MODIFICATION

Unauthorized modification or repair will invalidate all manufacturer declarations and guarantees.

IMPROPER USE

The control unit is not designed for any other use other than that stipulated in the general description. All operations must be within the specifications detailed in the technical data. Improper use also includes operating the equipment with excessive mechanical, static or dynamic loads (i.e. heavy machine parts or strong vibration). The inspection of aggressive materials such as those containing alkalis, acids and solvents is not permitted, nor is the equipment to be used in an environment where there is risk of explosion.

Electronic Enclosure

Dimensions

The enclosure houses and protects the Electronic boards and components and serves as a junction box for conduit and cables running to and from the Detector. As standard, the Detector is housed in a steel NEMA 4 rated enclosure. Other enclosures are available as options: NEMA 4X (304 or 316SS available), NEMA 7/9.

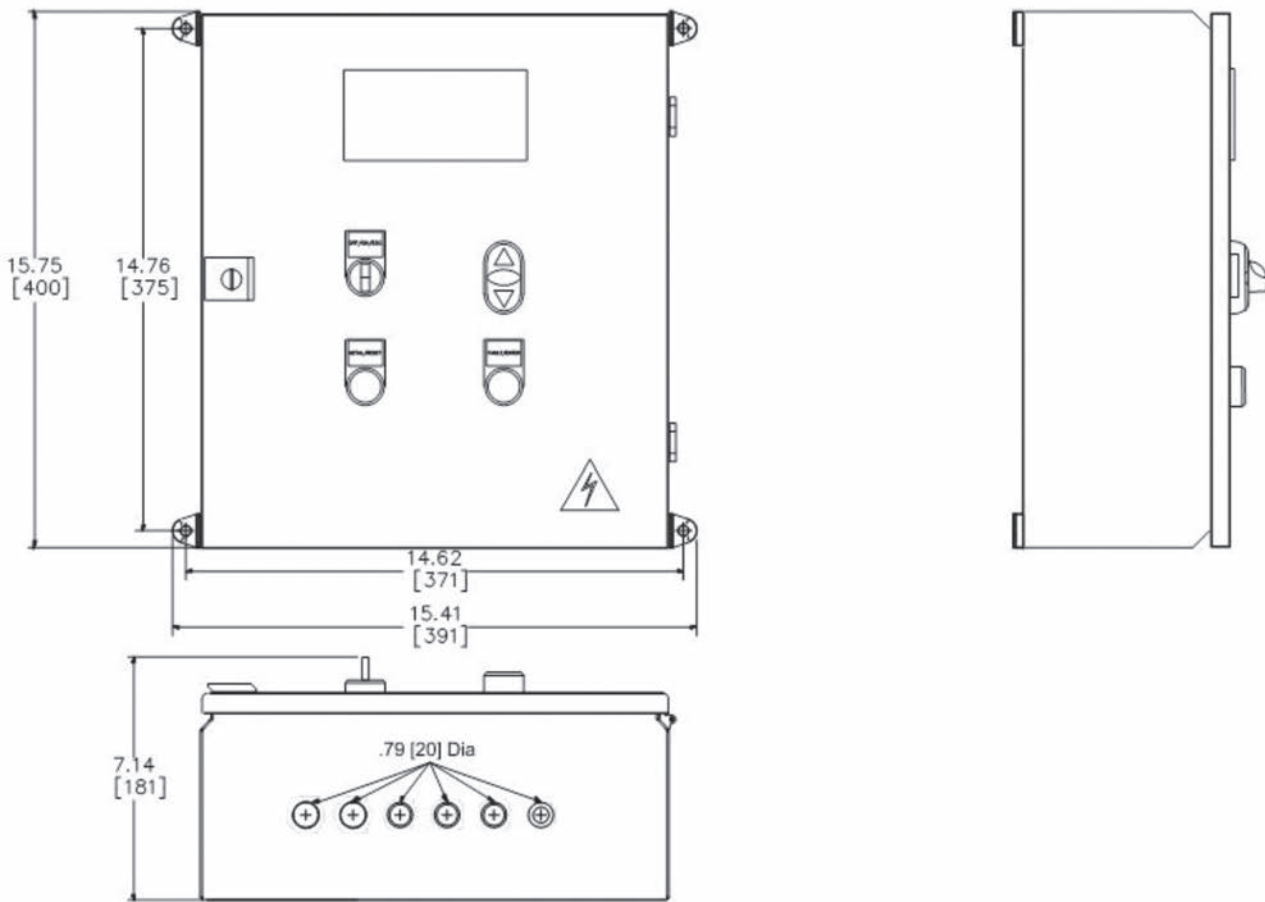

FIGURE 1

Technical Data

Name	Eriez 1230 Control Unit
Housing	Sheet steel, Powder Coated Gray
Weight	21 lbs (9.5 kg)
Ambient Temp.	-40°F to 149°F (-40°C to +65°C)
Ingress Protection	NEMA 4 standard Other Ratings Optional
Operating Voltage	115 / 240VAC (±10%), 50/60 Hz, 5A
Current Consumption	300MA/115V, 150MA/230V Typ. With No Output Load
Fuse	1.6A L250VAC, type FSF, 5x20mm
Switching Inputs	2 Switching Inputs: Remote Reset and Swing Away Switch 2 Switching Inputs for Initiators: clip detectors
Switching Outputs	1 relay switching output for metal signal (Output: Timed Out) 1 relay switching output for fault/alarm signal (Output: Fault) 1 relay switching output for metal signal (Output: Direct Out)
Operation	Rotating on/off and ESC (escape) switch Up and Down arrow buttons for menu navigation Fault Light / Enter Button Metal Light / Reset Switch VF Display

Electronic Control

Visible and accessible on the front panel are: 1) Display; 2) On/Off/Escape Switch; 3) Fault Light/Enter Button; 4) Metal Detected Light / Reset Button; 5) Up and Down Arrows

Adjustments and control functions are performed using the front control panel using the display screen, Up and Down arrows (5), Escape (2 – Turn clockwise), Enter (3 – Press), Reset (4 – Press). The detector is turned off by rotating the on/off switch (2) counter clockwise.

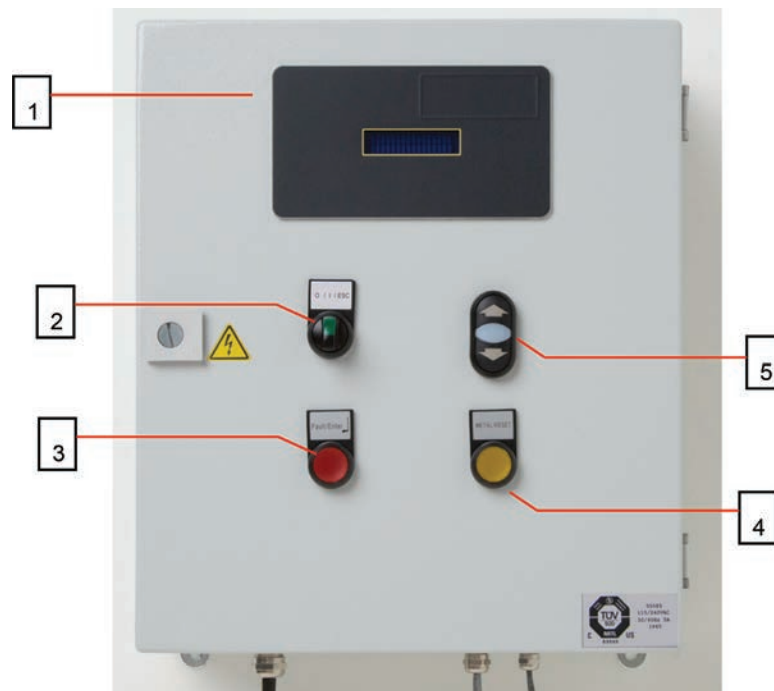
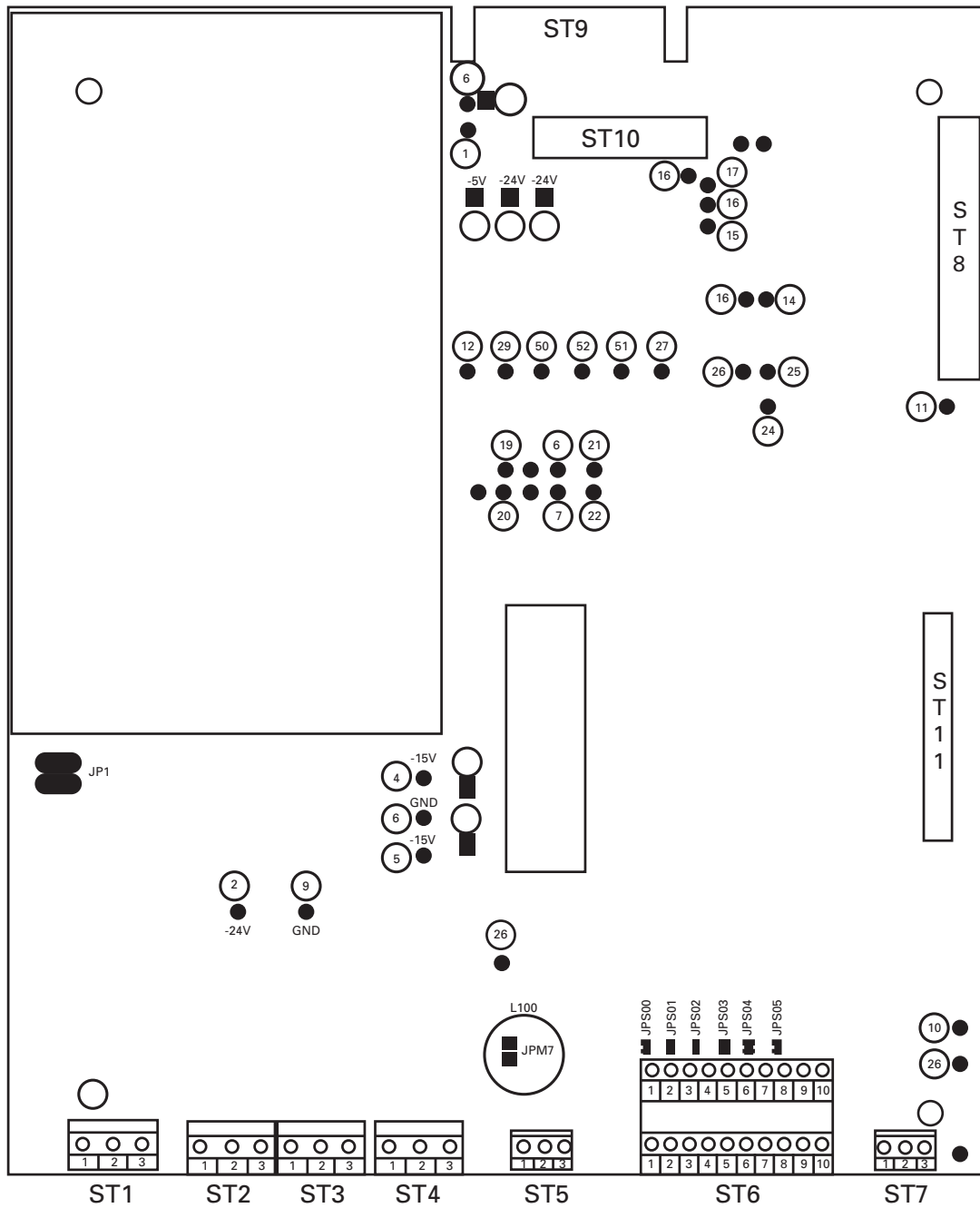

FIGURE 2



Electronics Board



Main Board (Rev.C)



Connectors and Terminals	ST1	“Mains”	Mains Supply
	ST2	“Direct Out”	Potential free change over contact (SPST)
	ST3	“Fault”	Potential free change over contact (SPST)
	ST4	“Timed Out”	Potential free change over contact (SPST)
	ST5	“Transmitter”	Transmitter Coil
	ST6	1-10: “Inputs”	11-20 “Input/Output”
	ST7	“Receiver”	Receiver Coil
	ST8	Ribbon Cable Connector	Connector for control panel
	ST10	Connector	Serial communication connection
	ST11	Connector	Connection for signal analyzer board
	Elements Connected to Mains Voltage	ST1	“Mains” connector
(1)		Mains fuses	
Elements Connected to External Voltage	ST2	“Direct Out” connector	
	ST3	“Fault” connector	
	ST4	“Timed Out” connector	
Memory Devices	(2)	Machine Data	
Lamps	LD1	Active light supply voltage +5V_D	
	LD2	Active light supply voltage +24V	
	LD3	Active light supply voltage -24V	
	LD4	Active light supply voltage +15V	
	LD5	Active light supply voltage -15V	
Test points	(3)	Supply voltage +24V	
	(4)	Supply voltage -24V	
	(5)	Supply voltage +5V_D	
	(6)	Supply voltage +15V	
	(7)	Supply voltage -15V	
	(8) - (12)	Common ground for earth (GND)	
	(13)	Pulse to transmitter coil	
	(14)	Signal from signal analyzer (or adapter board)	
	(15)	Signal to controller	

Signal Analyzer Board

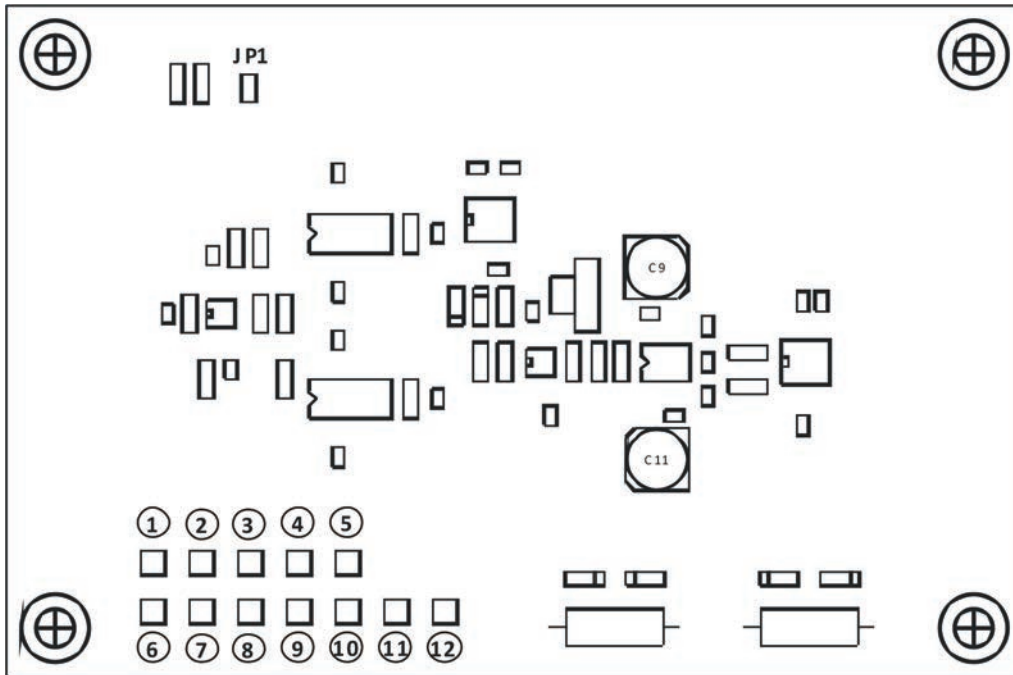

Test points and jumpers on the signal analyzer board

Test Points:	<ul style="list-style-type: none"> (1) Supply voltage +5V (2) Common ground for earth (DGND) (3) Supply voltage +15V (4) Common ground for earth (AGND) (5) Supply voltage -15V (6) DIS/ (not used) (7) Metal-Signal-OUT from signal analyzer (8) Zero pulse Z (9) Enable pulse EN (10) Sample Pulse S- (11) Sample Pulse S+ (12) Analyzer identification (+5V)
Jumpers:	<ul style="list-style-type: none"> JP1 Analyzer identification: Jumper must be closed

Search Coil Assembly

The Search Coil Assembly includes receiver and transmitter antennas, mounting frame and interconnecting cables. Each assembly is custom designed to suit its particular application. Please refer to the Frame Assembly Diagram.

Receiver Coil

The receiver coil is typically located under the conveyed material within 2" of the loaded conveyor belt.

Transmitter Coil

The transmitter coil is located opposite and parallel to the receiver coil. The distance between the transmitter and receiver (aperture) is typically 4" greater than the maximum burden depth of the processed material.

Mounting Frame

The mounting frame supports the antennas on trough and slider bed conveyors. Special designs are available to accommodate other types of material handling systems. The swing-away assembly, shown below protects the transmitter from oversized conveyed materials. See the "Mounting - Search Coil Assembly" section for assembly instructions

Interconnecting Cables

Shielded cables connect the receiver and transmitter to the Main Control Enclosure. 25' of cable between the frame assembly and control unit is supplied as standard. Optimum performance is assured with cable lengths of 25' or under. However, lengths of up to 100' are acceptable where detector sensitivity requirements are lower.

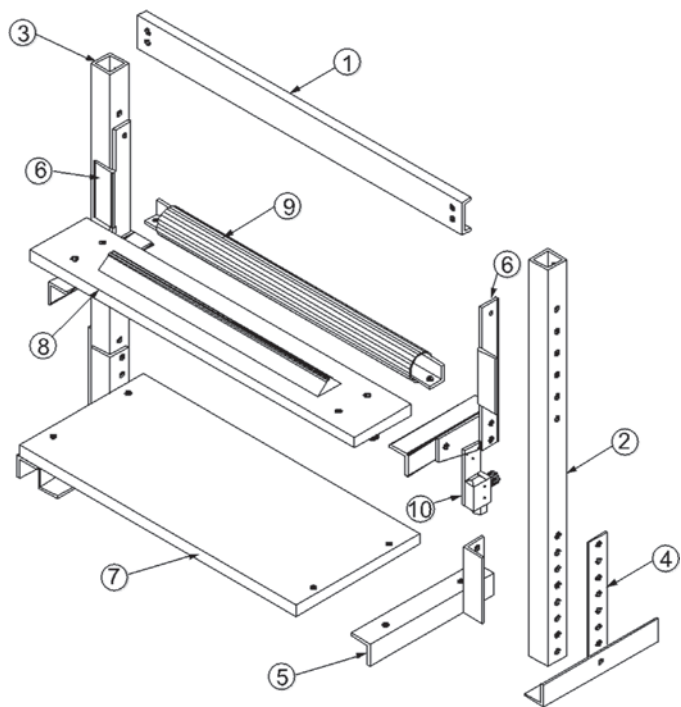

No. Name

- 1 Crossbar
- 2 Left upright up to 72" length
- 2 Left upright over 72" length
- 3 Right upright up to 72" length
- 3 Right upright over 72" length
- 4 Mounting feet carbon steel
- 5 Receiver Bracket Left
- 5 Receiver Bracket Right
- 6 Transmitter Bracket Left
- 6 Transmitter Bracket Right
- 7 Receiver Antenna (xx = coil length)
- 8 Transmitter Antenna (xx = coil length 1380Hz)
- 9 Roughing Guard (optional)
- 10 Swing-Away Switch (optional)

FIGURE 3

Clip Detector (if applicable)

The clip detector consists of a compact sensor head and mounting bracket. The clip detector senses the proximity of repair clips as they pass over the sensor's head. Once the clips are detected, the Metal Detector is desensitized, but not disabled. Any large piece of metal riding on the clips will still trigger the Detector. Size: 3.5" x 3.5" x 2", Weight: 1.25 Lbs. Clip Detector assembly comes with swivel mounting bracket and 25' of cable. Other lengths available.

Dual Clip Detector (if applicable)

Dual clip detectors are used on slow moving conveyors when the time it takes the clips to transition through the antenna zone is greater than maximum clip time of the controller, or variable speed conveyors where the time for the clip to pass through the detector could change. Two Clip Detectors are used, one is mounted upstream of the first upstream adjacent idler roller and the second is mounted downstream of the first downstream adjacent idler roller. The clip detectors are labeled "Upstream" and "Downstream" to indicate the location they should be placed.

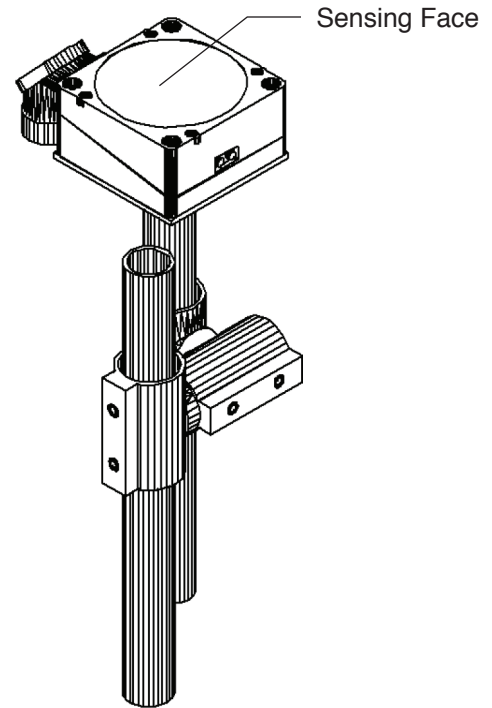

FIGURE 4

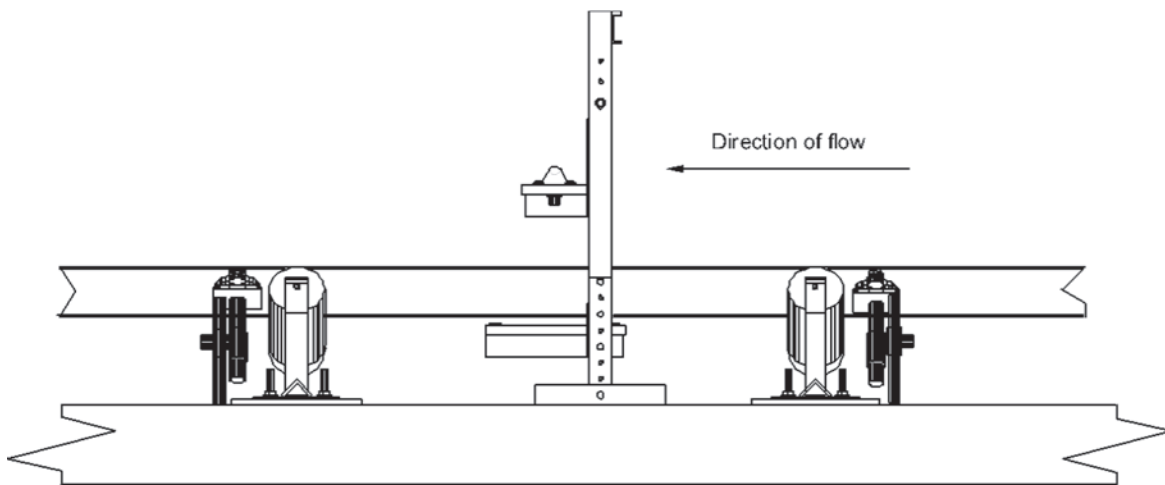

FIGURE 5

Spray Marking Device (if applicable)

The Spray Marking Device is a pressurized, solenoid activated liquid spray system which pinpoints the location of tramp metal to eliminate costly search and down time.

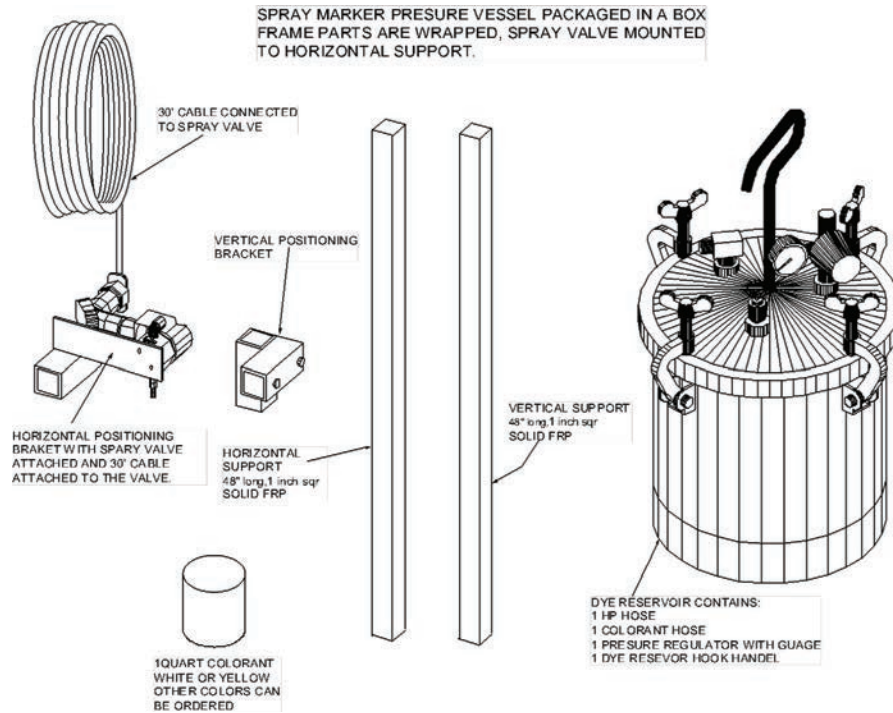

FIGURE 6

Flag Drop Marker (if applicable)

The Flag Drop Marker is a device which drops a tag or flag onto the belt which pinpoints the location of tramp metal to eliminate costly search and down time.

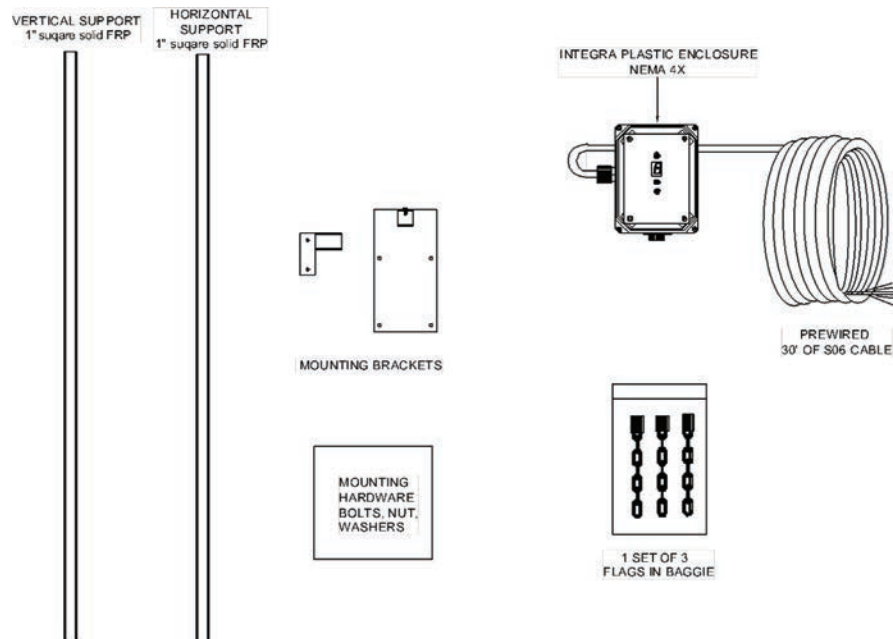

FIGURE 7



Idler Isolation Kit

The idler isolation kit is used to reduce or eliminate unwanted interference from the adjacent idler rollers.

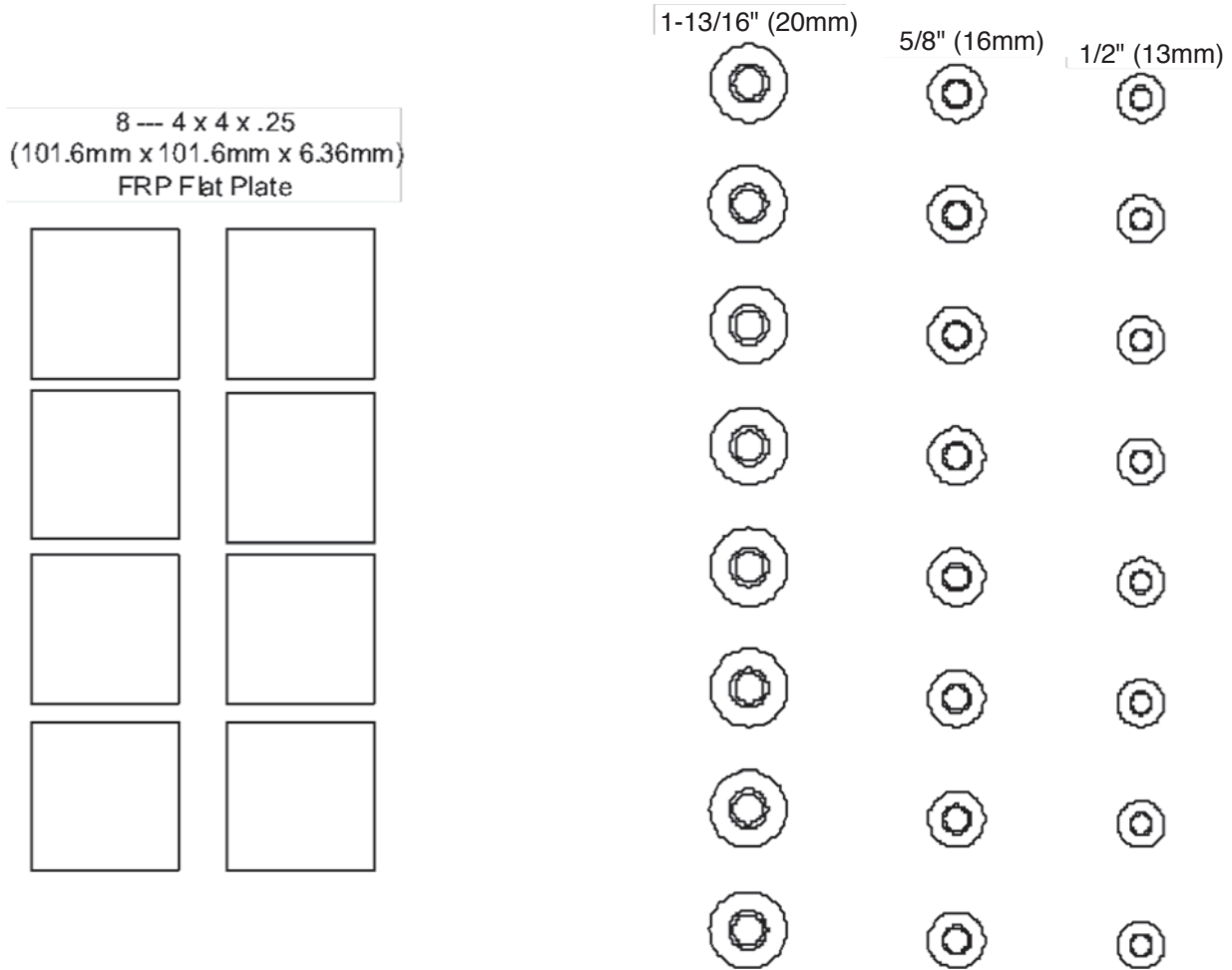

FIGURE 8

Multiple Unit Synchronization (if applicable)

Synchronization is used when two metal detectors are used within 100' of each other and are within a line of sight. Exception is when there is a metal wall or other metal structure between the two metal detectors to block the signals from the metal detectors.

Installation

PLEASE READ THROUGH COMPLETELY BEFORE BEGINNING WORK!

Recommended Tools

- 9/16" deep well socket & ratchet
- 7/16" wrench
- 3/32" flat head screwdriver
- #2 phillips and flat head screwdriver
- 9/16" wrench
- Needle nose pliers
- Crescent wrench
- Speed square

Unpacking

Upon receipt of the crate(s) containing the Metal Detector System, inspect the contents for physical damage and missing parts. If anything is broken or missing, please contact the carrier and notify the supplier immediately.

Site Selection & Preparation

While each application is unique, the guidelines listed below apply to most installations. Specific information concerning your installation can be found in the Frame Assembly and Control Connection Diagrams. Follow the steps listed below to choose the best location for the detector:

Choose a location for the detector so the material handling system has ample time to react to tramp metal. Locate the detector far enough in advance of the head pulley so the belt can come to a stop before the metal falls off the end of the belt. If a diverter is used, consider the reaction time of the system and speed of the conveyor belt.

Select a site with minimum vibration. High vibration areas may degrade detector sensitivity and shorten component life.

Locate the Search Coil Assembly away from sources of airborne electrical interference emitted from variable-speed drives, large motors, ballasts, FM radios, induction furnaces and other radio frequency (RF) sources. Because RF energy travels along a straight line (line-of-sight), position the receiver coil or relocate RF sources so they are out of the direct line-of-sight with the top and bottom of the receiver coil. Cables carrying high voltage or varying loads must be enclosed in steel conduit, grounded at both ends and located at least 4' from the detector antennas.

Position the entire search coil assembly so that the bottom coil (usually the receiver) is equally spaced between the two adjacent idler rollers. Use the receiver or transmitter coil connector as the center line. **Do not center the 2" x 2" uprights.**

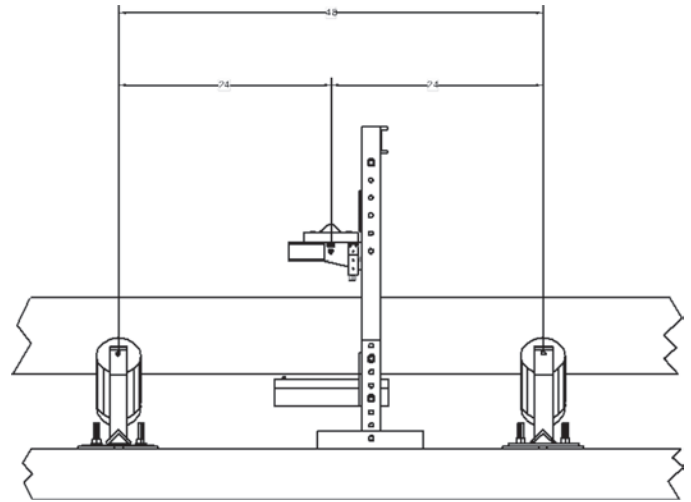

FIGURE 9

The magnetic field generated by the transmitter coil induces eddy currents in nearby metal cross bracing, stairways, handrails and pipes. These eddy currents may cause false tripping if the current path intermittently makes contact. Eddy current loops can be broken by cutting the conductive paths in these structures. Use non-metallic hardware as required to restore structural support.

Idler Roller Isolation

If conveyor idlers are used in your application, the idlers adjacent to the Search Coil Assembly require modification or isolation to break eddy current loops. An Idler Isolation Kit has been provided with your detector for this purpose. This contains shoulder washers in three different sizes, (8) 1/2" (12mm) Id, (8) 5/8" (16mm) Id, (8) 13/16" Id and (8) 4" X 4" FRP plates. The FRP plates should be placed between the idler mounting flange and the conveyor frame, and secured with the idler roller hardware. Refer to the Conveyor Idler Modification Diagram for details. Figure 10.

If the Search Coil Assembly is located where a metal skirt passes through the coils, it must be replaced with a five-foot section of non-metallic material (i.e., wood or plastic).

Remove metallic decking, skirt boards, cross bracing and return idlers below and within 3' of the center line of the receiver coil (upstream and downstream). Relocate or tightly secure moving or vibrating pieces of metal such as cables, conduit and piping within 36" of the Search Coil Assembly.



ITEM	QTY	DESCRIPTION
1	8	Shoulder Washer 1/2" ID (12mm)
2	8	Shoulder Washer 5/8" ID (16mm)
3	8	Shoulder Washer 13/16" ID (20mm)
4	2	Isolation Pad, Fiberglass 4" x 4" x 1.4" Thk (Set of 4)

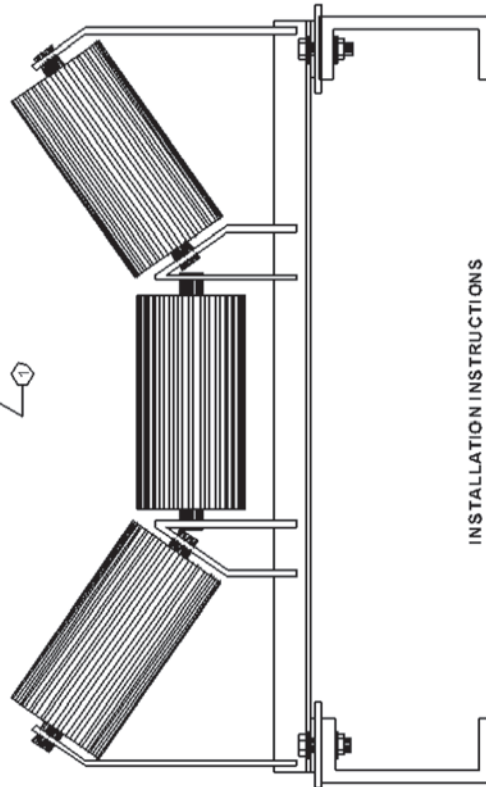
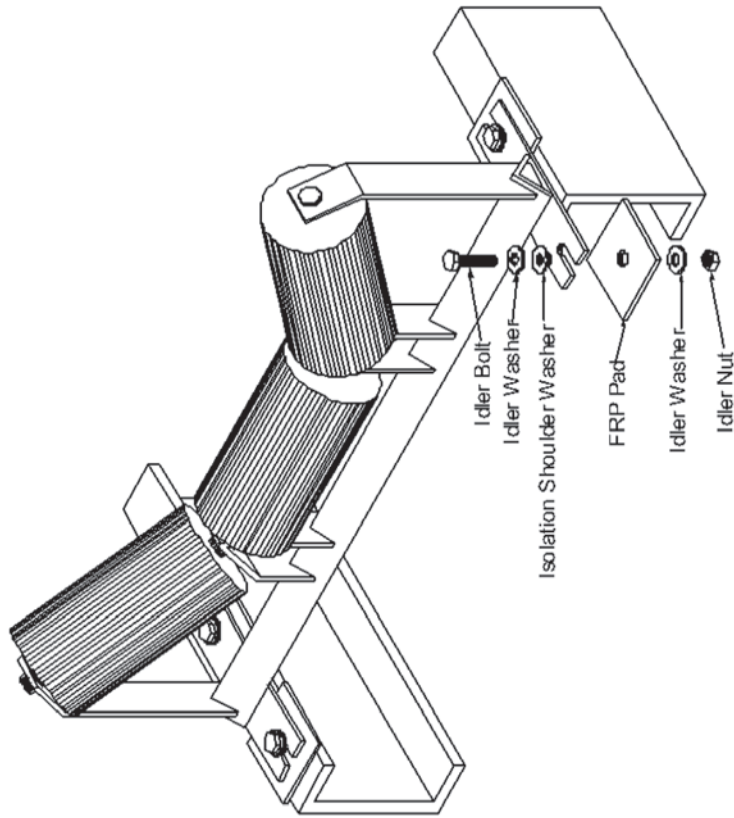
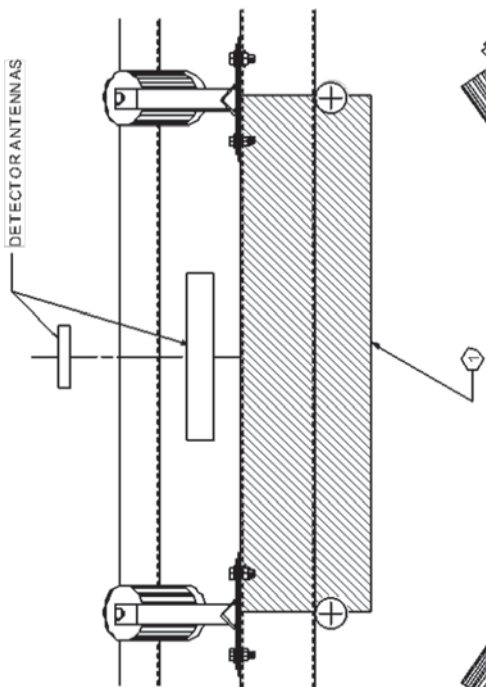

1. Remove the adjacent idler on either side of the detector installation location.
2. Select Shoulder Washers that is the closest fit for the idler bolt.
3. Position 4 isolation pads under idler feet (two on each side) so they are centered on the idler foothole, drill a hole into the four isolation plates large enough to allow the shoulder washer flange to fit.
4. Re-mount the idlers onto the frame so that the isolation plates are in between the idlers mounting foot and the conveyor frame. Secure the idlers with the bolt, washers, shoulder washer and nuts. When completed, the idler will be electrically isolated from the conveyor frame.

NOTE: Be sure to use a metal flat washer on top of the nylon shoulder washer to spread the bolt head pressure evenly.

⚠ NO METAL DECKING, CROSSBRACING, OR RETURN IDLERS BELOW OR BETWEEN IDLERS ADJACENT TO RECEIVER ANTENNA.

FIGURE 10

Mounting – Search Coil Assembly

Note the material flow direction arrows, match marks and other identification on the Detector components before beginning work. Please refer to the Frame Assembly Diagram for installation, Figure 11.

Assemble the top crossbar to the vertical upright supports using four 3/8" x 1" bolts with washers (provided) use needle nose pliers to hold the bolts and install the bottom bolts first. Be sure the crossbar is located on the upstream side of the upright supports and the base of the metal mounting feet angles point in toward the belt.

Assemble the top transmitter coil (with swing-away brackets attached) to the upright supports. The height of the transmitter coil should be as low as possible without being hit by overburden. The nominal height for the transmitter coil is indicated by dimension "S" on the Frame Assembly Diagram. Use two 3-1/2" bolts with washers (provided). Each of the two bolts contains four flat washers and two nuts. Make sure two washers are located between the swing-away bracket and upright support to insure proper spacing and freedom of movement. The remaining washers are located at the end of each bolt. Tighten, by hand, each bolt with a nut until light drag is exerted on the swing-away bracket. Tighten the second nut against the first nut to serve as a jam nut. Verify that the swing-away brackets are free to move.

CAUTION

If the swing-away assembly is not free to move, damage to the transmitter coil may result if hit by overburden.

Position the upright assembly onto the conveyor frame with the arrow on the transmitter coil pointing in the direction of belt flow.

Assemble the receiver coil (mounting brackets attached) to the upright supports using four 3/8" x 3-1/2" bolts with washers (provided). Position the height of the receiver coil as close as possible to the belt. The nominal height for the receiver coil should be 1" to 2" below the conveyor belt, allow for belt sag under load. Bolt the brackets into place with the nuts and washers facing in toward the belt.

Verify that the search coil assembly is square and all bolts installed are properly tightened.

Position the entire search coil assembly so the bottom receiver coil is equally spaced from the idler rollers on either side.

Weld or bolt the metal support feet to the conveyor frame. Be sure unwanted twists and torques in the frame assembly are corrected before you weld. A twist in the frame may cause the swing-away bracket to pull away from the upright support. This may cause the transmitter coil to bounce from vibration while in operation.



Frame Assembly

No. Name

- 1 Crossbar
- 2 Left upright up to 72" length
- 2 Left upright over 72" length
- 3 Right upright up to 72" length
- 3 Right upright over 72" length
- 4 Mounting feet carbon steel
- 5 Receiver Bracket Left
- 5 Receiver Bracket Right
- 6 Transmitter Bracket Left
- 6 Transmitter Bracket Right
- 7 Receiver Antenna (xx = coil length)
- 8 Transmitter Antenna (xx = coil length 1380Hz)
- 9 Roughing Guard (optional)
- 10 Swing-Away Switch (optional)

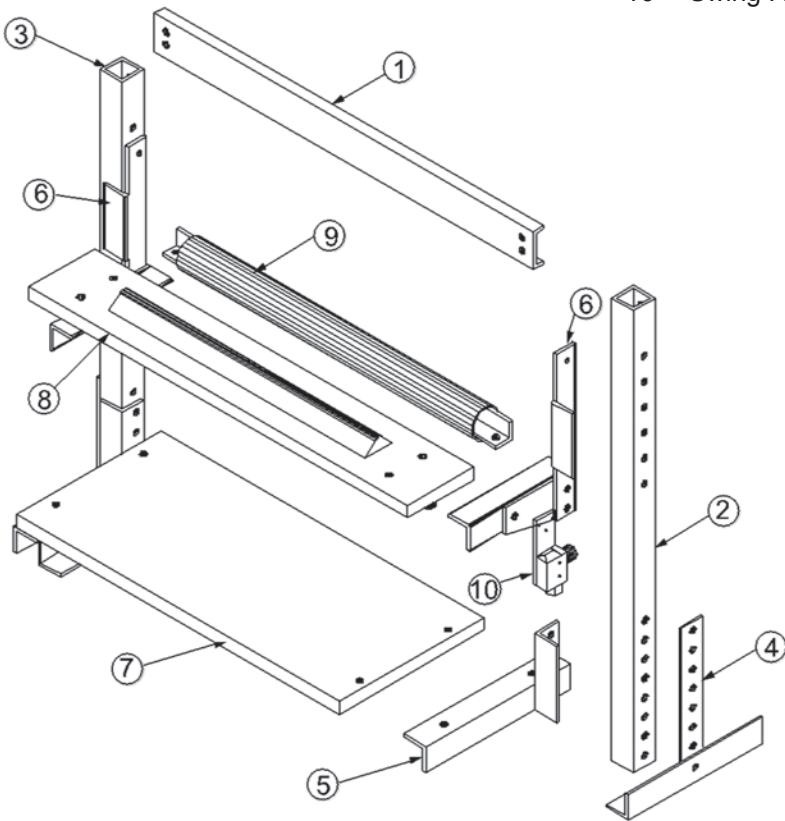

FIGURE 11
Frame Assembly Diagram

Mounting – Main Control Enclosure

After installing the Search Coil Assembly, select a place to mount the Main Control Enclosure for ease of operation and within the length of the cables provided. Avoid high vibration areas. **DO NOT INSTALL IN AN ENVIRONMENT WHERE THERE IS A RISK OF EXPLOSION.** Note the length of interconnecting cables and the location of the connectors on the coil. Locate the Control Enclosure on the same side of the conveyor frame as the connectors for ease in routing the cables.

The Enclosure should be positioned so the front panel hinge is on the Right side and the display is on top. Fix control unit cabinet to wall or frame using the 4 screw holes provided (check the drawing under “Electronic Enclosure Dimensions” for dimensions). Ensure that it is securely fixed to support the weight of the control unit (approx. 21lbs [9.5kg]). The detector electronics must be installed in its own cabinet. **DO NOT** install it in other cabinets with other electrical equipment as there is a high risk of interference.

Fabricate and install a sun/rain shade for added protection over the Enclosure if it is mounted outdoors. Do not obstruct the natural airflow around the Enclosure.

Familiarize yourself with the type of electrical connections required for this installation and any safety precautions before proceeding. Please refer to the Appendix A control connection diagrams for information about connections and color code hook-up.

Use the existing entry holes on the bottom of the Enclosure. Do not run metal conduit along the sides or near the Search Coil Assembly.

Transmitter and receiver cables do not need to be in conduit but they need to be secured to the conveyor frame. If there is a danger of cables being cut or damaged by the product then the cables should be routed in conduit, for protection of the cables. **Do not run any power wiring in the same conduit or near the transmitter and receiver cables. Always discuss with Eriez before altering cable length. Always use original cables supplied with unit.**

Synchronization of several metal detection units: If several metal detectors are installed within 100' (30m) of each other, a shielded 2 core “twisted pair” cable must be used to synchronize them. This must be connected according to Figure A18 in Appendix A

Swing-Away Switch (if applicable)

The Swing-Away Cutout Switch (Optional) is a pre-wired switch mounted on the swing-away bracket. Its purpose is to prevent the Metal Detector from tripping when the transmitter coil is hit by an overburden of material. Route the free end of this cable in the same conduit as the transmitter cable to the Main Control Enclosure. Be sure to leave enough slack in the cable to allow the transmitter antenna to swing freely. Refer to Control Connection Diagram Appendix A Figure A7 for connection instructions.

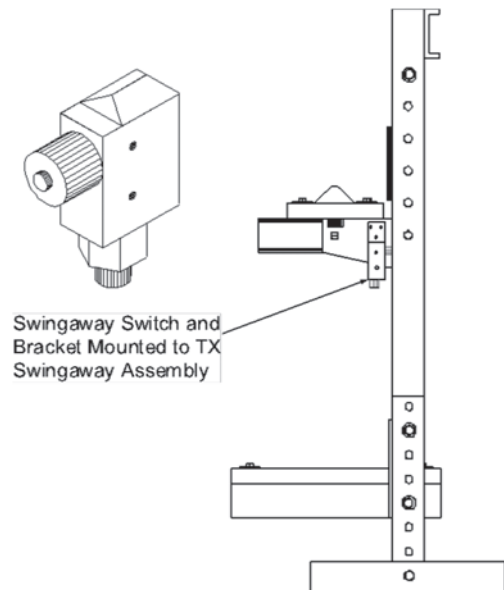

FIGURE 12

Clip Detector (if applicable)

Install the clip detector unit as follows:

Refer to the Control Connection Diagram Figure A8 in Appendix A, for hookup, and Figure 13 for placement. If there are idlers adjacent to the search coils, position the Clip Detector Sensor approximately 2" upstream of the nearest upstream idler before the Search Coil Assembly.

For slider bed type conveyors, position the Clip Detector Sensor approximately (but no closer than) 2' from the center line of the receiver coil on the upstream side of the Search Coil Assembly.

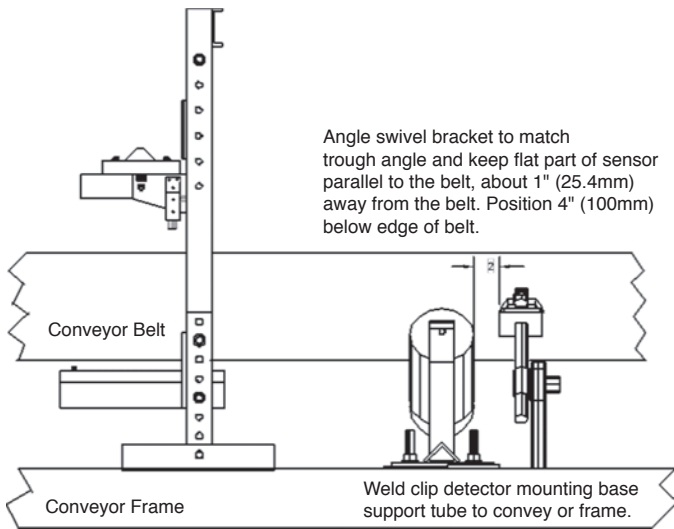

FIGURE 13

With the Clip Detector Sensor in the proper position below the belt, weld the 3/4" support pipe (provided) to the conveyor frame. The pipe may be cut to the proper

size for an easier fit or the pipe may be replaced by a longer 3/4" pipe if the supplied length of pipe is not long enough for proper mounting of the clip detector sensor. The multi-axis swivel joint will provide adequate movement for proper adjustment.

The flat face of the Clip Detector should be facing toward the belt with approximately 1/2" to 1" of clearance. **This clearance must be maintained in order to assure proper operation.** The Clip Detector should be a few inches from the edge of the belt. Do not mount the Sensor too far from the edge, as tramp metal lying close to the belt may trigger the sensor and pass through the search coils as a repair splice.

It is not required but recommended that the Clip Detector cable running to the Main Control Enclosure be installed in conduit. The same conduit that houses the transmitter coil cable may be used.

Feed the Clip Detector cable into the conduit from the Clip Detector end to the Main Control Enclosure. Cut off excess cable. Connect wires to terminal block. Be certain all wires are attached securely and connected to their proper terminals.

When metal repair clips are used, two or more clips close together must pass directly over the Clip Detector Sensor in order to activate it. If a small patch of clips is used on the belt, which would not pass directly over the Clip Detector, reference clips are required. Reference clips are made by installing two or more clips which will pass directly over the Clip Detector to trip it when a small patch passes by, see Figure 14. Numerous repair and reference clips on the belt will degrade the Detector's performance because it will frequently be in a desensitized mode.

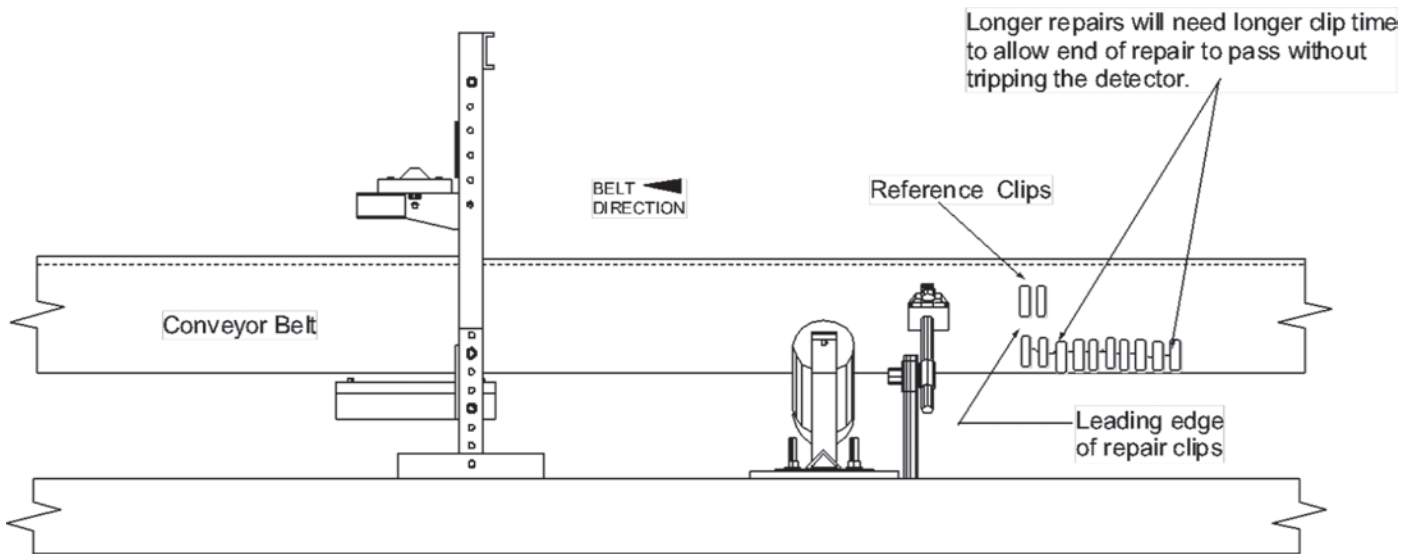

FIGURE 14



Dual Clip Detector (if applicable)

Refer to the Control Connection Diagram Appendix A Figure A9, for hookup, and Figure 15 for placement. Idler roller type conveyor position the Up Stream Clip Detector Sensor approximately 2" upstream of the nearest upstream idler before the Search Coil Assembly. Next position the Down Stream Clip Detector Sensor approximately 2" down stream of the nearest down stream idler after the Search Coil Assembly.

With the Clip Detector Sensor in the proper position below the belt, weld the 3/4" support pipe (provided) to the conveyor frame. The pipe may be cut to the proper size for an easier fit or the pipe may be replaced by a longer 3/4" pipe if the supplied length of pipe is not long enough for proper mounting of the clip detector sensor. The multi-axis swivel joint will provide adequate movement for proper adjustment.

The flat face of the Clip Detector should be facing toward the belt with approximately 1/2" to 1" of clearance. **This clearance must be maintained in order to assure proper operation.** The Clip Detector should be a few inches from the edge of the belt. Do not mount the Sensor too far from the edge, as tramp metal lying close to the belt may trigger the sensor and pass through the search coils as a repair splice.

It is not required but recommended that the Clip Detector cable running to the Main Control Enclosure be installed in conduit. The same conduit that houses the transmitter coil cable may be used.

Feed the Clip Detector cable into the conduit from the Clip Detector end to the Main Control Enclosure. Cut off excess cable. Connect wires to terminal block. Be certain all wires are attached securely and connected to their proper terminals.

Spray Marking Device (if applicable)

The Spray Marking Device is a pressurized, solenoid activated liquid spray system which pinpoints the location of tramp metal to eliminate costly search and down time.

Specifications

Tank Pressure Rating: 50 psi

(maximum working pressure)

Tank Capacity: 2.5 Gallons (liquid)

Operational Voltage: 115/220 VAC (50/60 Hz), 15 Watts

Air: Plant air or any source of 100 to 200 psi inert gas

Installation Instructions

Refer to the Figure 16 for mounting of the Marking Device on the conveyor frame and refer too Figure 17 for positioning of spray marker support and valve assembly.

Position the solenoid support upright and cross arm as shown. Distance from the coils should be 5' to 10' (1.5 to 3m). Clamp in place temporarily.

Position the support bracket of the solenoid spray valve so that the nozzle is pointed directly on the center of the conveyor belt. The nozzle may be positioned as shown or on the opposite side of the arm. Bolt the bottom of the support frame to the conveyor frame.

The solenoid control cable is connected to the Timed Output Relay. Route the cable accordingly.

Connect the hose between the tank outlet and the solenoid valve.

Connect the facility air source to the tank regulator inlet. Be sure the facility air source is shut off and no pressure is in the tank.

Remove the top of the spray tank.

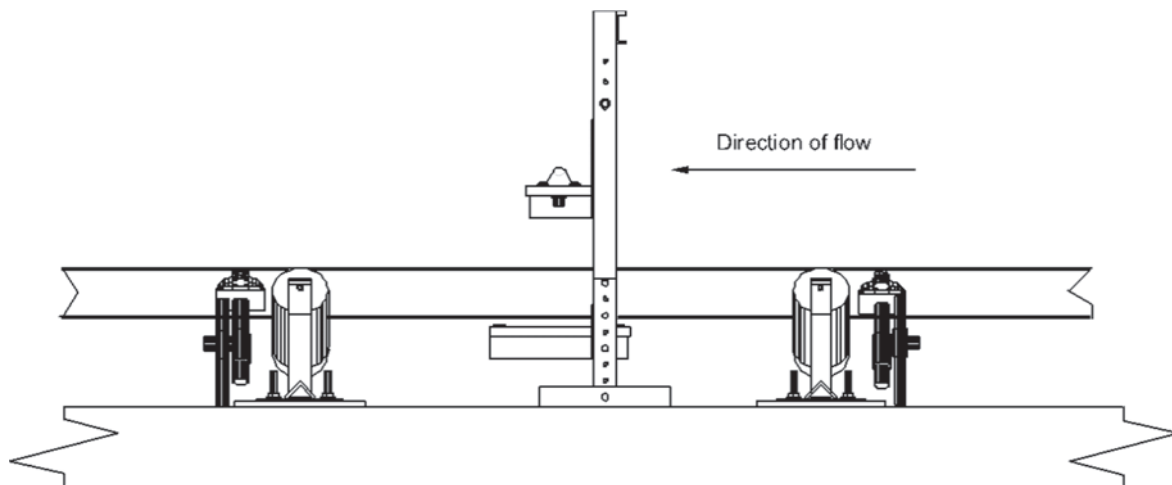

FIGURE 15

The spray solution can be purchased from Eriez or supplied by the User. The recommended mixture is five (5) fluid ounces of colorant, Chrome Yellow (or other contrasting color) mixed with a two (2) gallon solution of water and antifreeze appropriate for local climate conditions (minimum of 25% antifreeze). Antifreeze has two functions: 1) to keep the water from freezing in cold climates and 2) it will keep the colorant from being absorbed by the product, so a greater concentration antifreeze increases the time the colorant stays on top of the product. If colorant absorption is a problem then use antifreeze without water. **DO NOT USE PAINT. Paint will clog the spray valve.**

Mix the solution and pour it into the holding tank.
Replace the cap.

Verify that the pressure regulator valve is closed prior to turning on the facility air.

Apply the facility air and adjust the pressure regulator between 60 and 100 psi, as noted on the pressure gauge on top of the holding tank.

Calibration of Marking Device

Refer to “Marking Device Calibration” under “Start-Up & Calibration” to set the desired timing for marking a predetermined location.

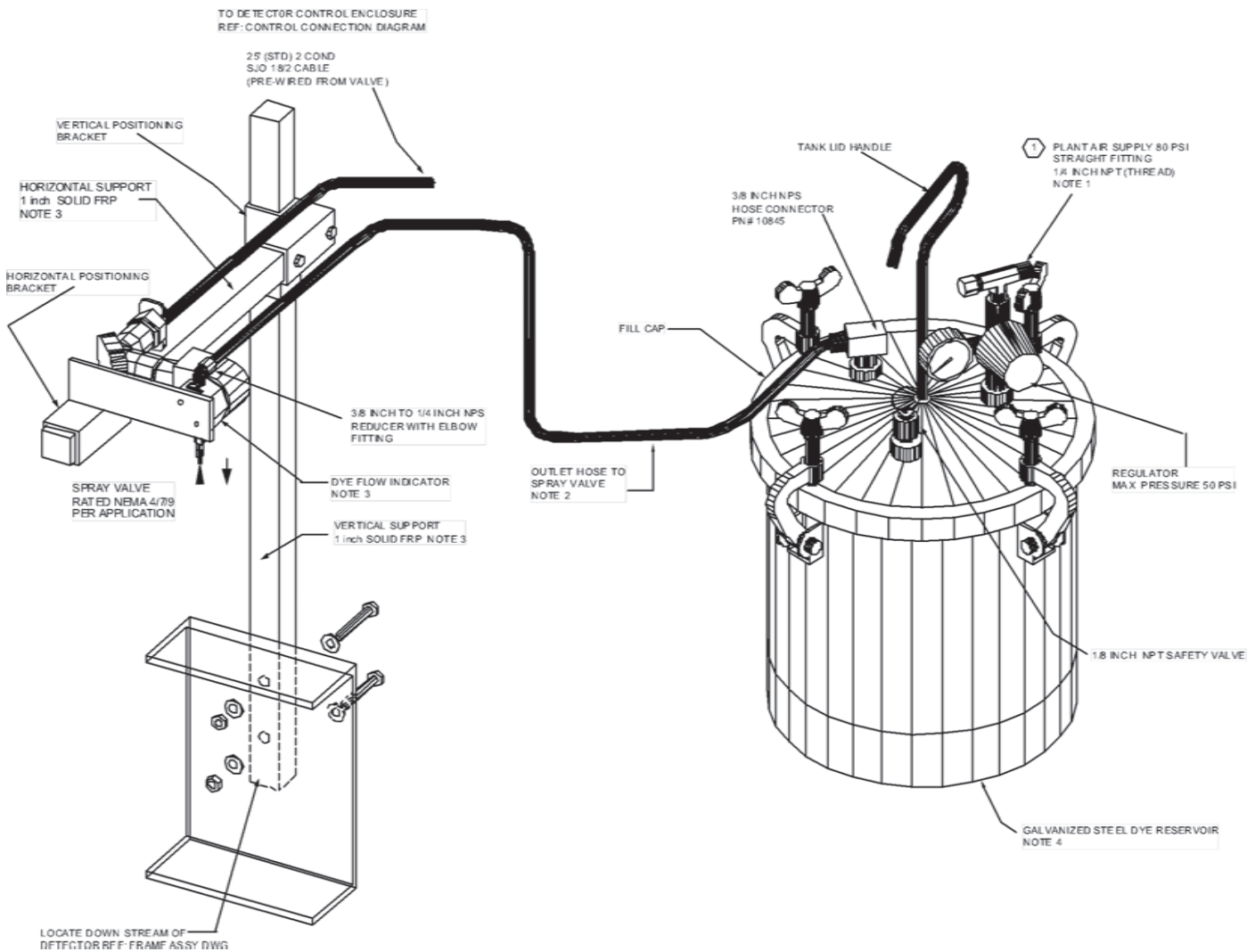

FIGURE 16
Mounting the Spray Assembly

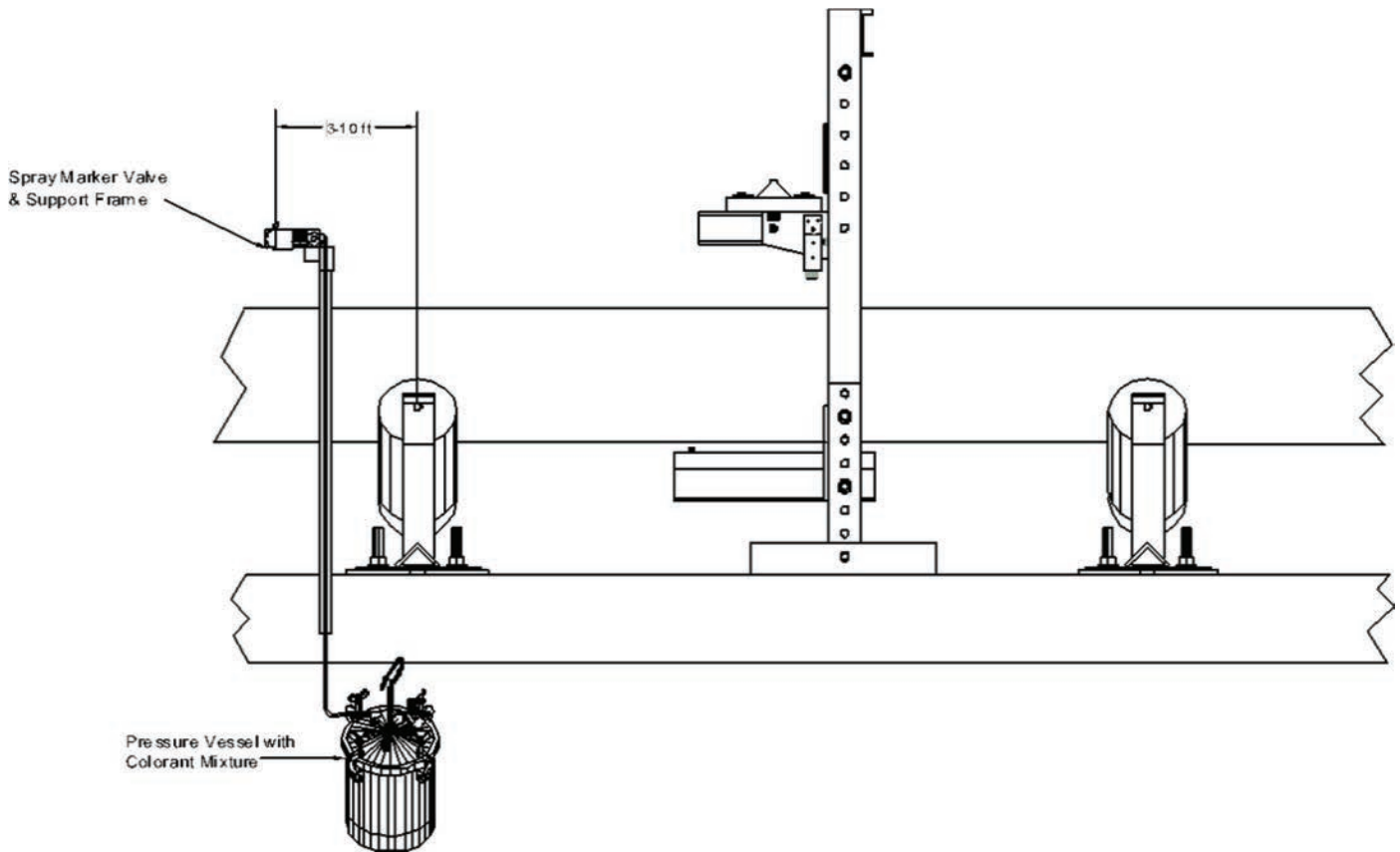

FIGURE 17
Positioning the spray assembly

Flag Drop Marker (if applicable)

The Flag Drop Marker is a device which drops a tag or flag onto the belt which pinpoints the location of tramp metal to eliminate costly search and down time.

Specifications

- Plastic NEMA 4X box which holds the electronics and flag
- One set of 3 flags
- Operational Voltage: 115/220 VAC (50/60 Hz), 15 Watts

Installation Instructions

Refer to the Figure 18 for mounting and Figure 19 for positioning of the Flag Marking Device.

Attach the upright support to the upright. Position the frame upright in front of the first downstream idler roller. Lay the upright support on the top of the C channel and adjust the upright so that it is straight up and down.

Clamp in place now drill a hole in the side of the C channel to secure the bottom of the upright and drill a couple of holes through the upright support and top of C channel and secure the support to the conveyor C channel.

Attach the frame cross bar with gusset to the upright.

Mount the NEMA box to the cross bar. Position the box on the cross bar so that the flag will drop on the product where the edge of the product touches the belt, (if the product comes to the edge of the belt then position the box so the flag is far enough in so that the flag does not fall off of the belt).

Route the power cord across the cross bar and down the upright, secure cord with Ty-raps. Make connections to the Metal Detector electronics reference Appendix A figure A10.

Calibration of Flag Drop Marker

Refer to "Marking Device Calibration" under "Start-Up & Calibration" to set the desired timing for marking a predetermined location.

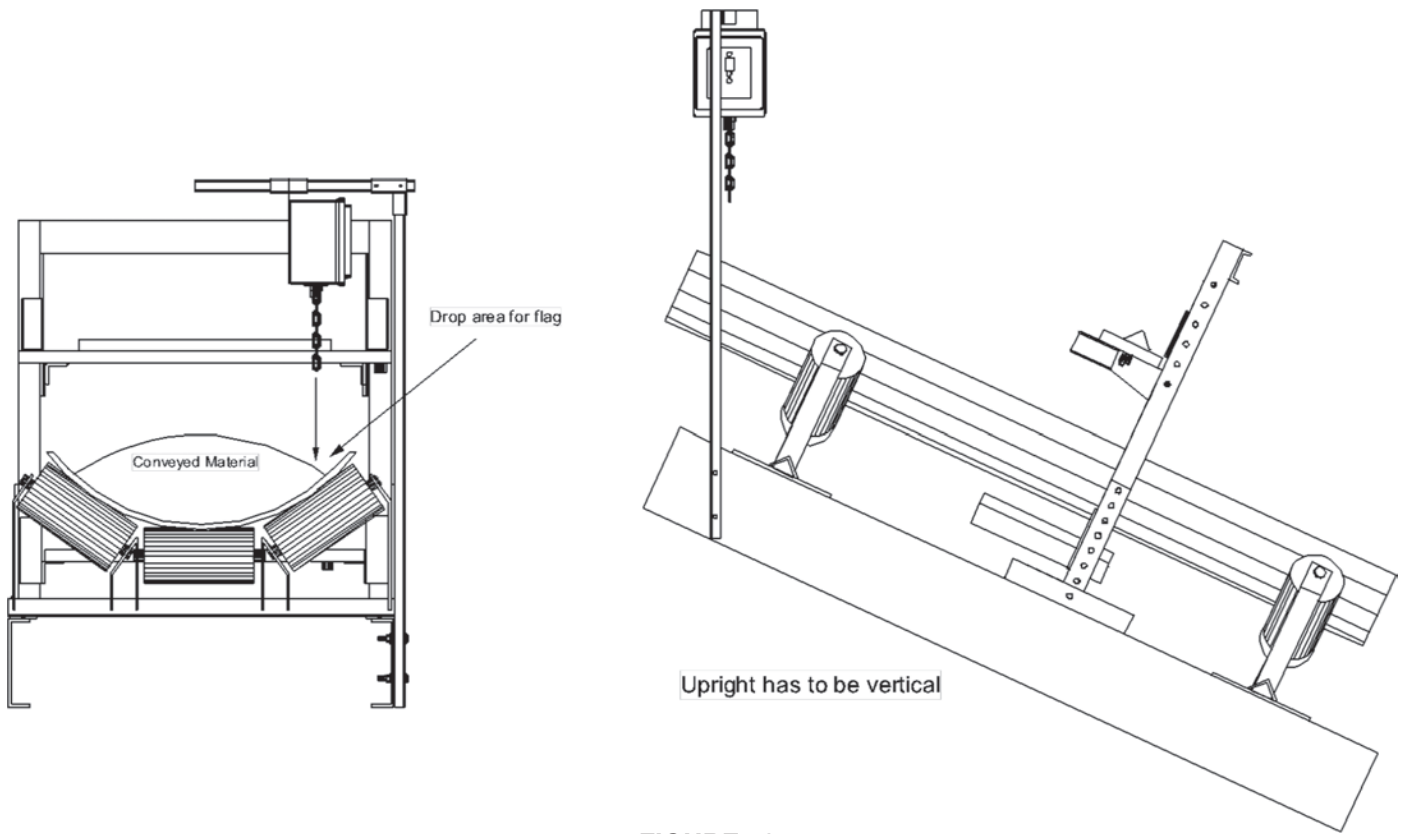

FIGURE 18
Mounting of the flag drop marker

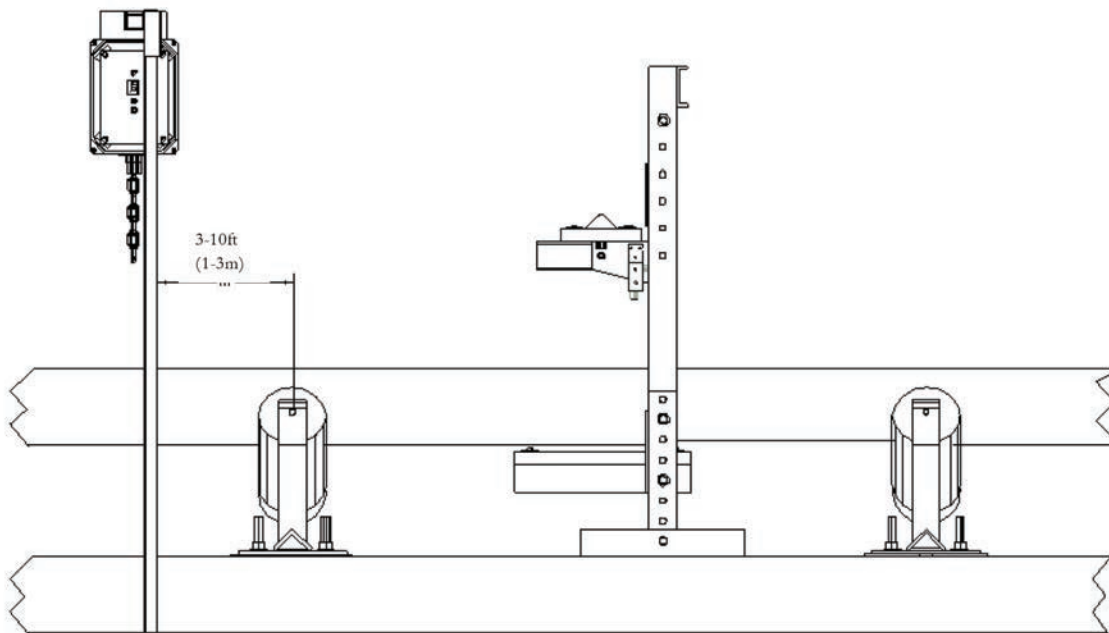

FIGURE 19
Positioning the flag marker

Start-Up & Calibration

Start-Up

Before applying power to the system make sure that all of the connections are correct.

Apply power.

“**Please Wait**” will be displayed on the display while the computer boots up. After about 10 seconds the display will change to “**SIGNAL STRENGTH**” with a bar graph under and the Green LED “Ready” indicator should be lit. If there are any problems with the connections or there is a problem with the electronics an error message will be in the display window and the Red “Fault” LED will be illuminated. Refer to “Errors and Fault Rectification”

Lamps and outputs during start-up phase:

Output	Contact Status
Green Light	Illuminated
Red Light	Off
Yellow Light	Off
Metal Relay 1 - Direct Out	Contacts 31 and 32 closed (consistent with no metal alarm)
Fault Relay	Contacts 21 and 24 closed (consistent with no metal alarm)
Metal Relay 2 - Timed Out	Contacts 11 and 12 closed (consistent with no metal alarm)

Lamps and outputs after start-up phase:

Output	Contact Status
Green Light	Illuminated
Red Light	Off
Yellow Light	Off
Metal Relay 1 - Direct Out	Contacts 31 and 34 closed (when metal is detected)
Fault Relay	Contacts 21 and 22 closed (when fault detected)
Metal Relay 2 - Timed Out	Contacts 11 and 14 closed (when metal is detected)

Operation

General advice for operation

- To operate the Eriez 1230 Metal Detector use the **UP, DOWN, ENTER** ↵ and **ESC** keys.
- The key symbols displayed show that changes can be made in the choice of screen and also in value setting.
- The **ESC** key returns the operator from any settings screen to the main screen.
- By pressing the **Reset** key the operator resets the machine manually after a metal event.
- If no further action is taken the program automatically returns to the main screen after 30 seconds.

Display Screens

1. **Operating screen:** is shown on the display during normal operation. 2 different Operating screens can be set. Change operating screen by holding down the **ESC** key, at the same time pressing the **UP** key.

Example of Operating Screen

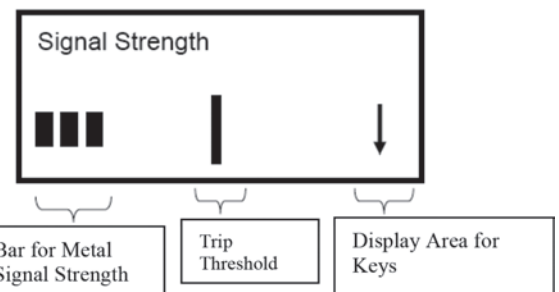

2. **Menu Selection:** use the Up/Down buttons to move to the desired menu, then use Enter ↵ key to select that menu.



3. **Settings screen:** Use the UP/DOWN buttons to change the setting or value. Changes are confirmed by pressing Enter ↵. If after making changes, only the ESC key is pressed, the old settings will remain.

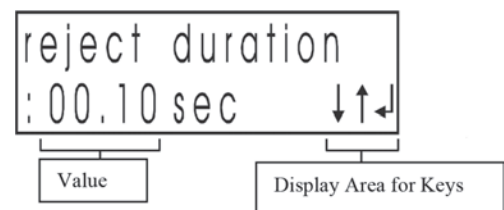

Main Menu

Operating screen: is shown on the display during normal operation. 2 different operating screens can be set. Change operating screen by holding down the ESC key, at the same time pressing the UP key.

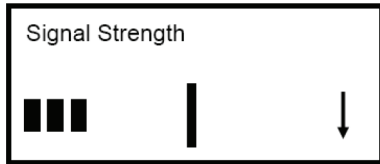

Operating screen 1:

Information shown

Metal signal as bar graph

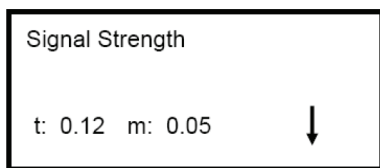

Operating screen 2:

Information shown

t: Trip threshold

m: Metal signal

i INFORMATION

If metal is detected the metal signal with the maximum value will be retained momentarily and displayed as a bar or a reading (eg: m: 0.8).

If a clip is detected by the clip detector, the message >> CLIP MODE << appears. The system will adjust itself to the previously set clip sensitivity.

If a swing away cut out switch is installed and something hits the transmitter coil the message >> SWING AWAY << appears on the display and metal detection is switched.

Off until the transmitter antenna returns to its normal position. If no swing away switch is present, this will most likely cause the metal detector to trip.

If excess voltage is detected by the 80 C2 signal analyzer the message >> SURGE << appears and metal detection is switched off.

Metal Sensitivity Calibration

Before proceeding with the calibration procedure, obtain two samples of tramp metal: one piece should be larger than the minimum size to be detected and the other smaller. These samples will be used to calibrate the Detector and should represent the type of metal most likely found in the conveyed material. Pass the metal about half way up between the transmitter and receiver antennas. Note: optimum metal shape of tramp would be a sphere or cube because the metal signal that is produced by the cube or sphere is the same regardless of orientation. If an elongated shape is used then the piece of metal will need to be tested so that all three orientations are presented. Orientation 1, up and down so that the metal is pointing up to the transmitter antenna and down to the receiver antenna. Orientation 2, side to side so that the metal is pointing across the belt. Orientation 3, forward and back so that the metal is pointing in the length wise direction of belt. One of these orientations will give a weak signal. This is the orientation that the detector should be set up for.

Observe the display window. When the piece of metal is passed between the antennas the bar graph will indicate the signal strength. There is a vertical threshold bar on the LCD display. When the signal level reaches or passed the threshold bar the detector will trip.

Pass the larger metal between the antennas. If the test metal does not cause metal detector to trip and illuminate the "Metal" light or the bar graph deflects all the way to the right then sensitivity adjustment will need to be adjusted.

Sensitivity is adjusted by going to the sensitivity adjustment menu. Press the Down Arrow once, "settings" will be displayed. Press the "enter" key (the bent arrow button), "sensitivity" will be displayed. Press the enter button, "sensitivity: ##%" will be displayed. Using the up and down arrows the percentage of sensitivity can be changed. Adjust the percentage of sensitivity and then check the bar graph level so that the bar graph deflects about 3/4 of the way to max.

Pass the smaller metal between the antennas and it should not trip the detector. If the detector trips with the smaller metal then the sensitivity adjustment needs to be reduced.

Clip Detector Calibration (if applicable)

The clip detector can be set up two ways:
Automatic or Manual.

Automatic Setup

Automatic Setup will automatically calibrate the clip time and sensitivity for the clips. Follow Press down arrow "settings" will appear in the display window.

Press enter, "sensitivity" will be displayed, press the down arrow 5 times until "setup" is in the display window press enter, "code" will be displayed in the window. Using the up and down arrow enter the number **3080**. Press up arrow until "3" is displayed press enter, an X will be over the three that was just entered and the cursor will have moved one place to the right and a "0" will be displayed, press "enter". Press the down arrow a couple of times until the number is "8", press "enter". A "0" will be in the display press "enter". The display will have "conveying speed" in the window. Press the down arrow until "clip mode" appears in the window, press "enter". "Single" should be in the display, if "dual" is displayed then use the up or down arrow to change the display to "single", press "enter". Press the down arrow until "clip learning" appears in the window and press "enter". "waiting for clip" will be in the display window. When you see the clips coming press the "enter" button, "learning mode activated" will be displayed. Once the clips pass over the clip detector and is in between the antennas the display changes to "durat.: xxx.sec. sens.: xx %". This display will show how long it took the clip to pass from the clip detector to the antenna then display will change to "re-learn: ESC, Accept "enter". Press "enter" to accept the clip settings, or "ESC" to relearn. The clip time and clip sensitivity will be automatically entered. It is important that the "clip duration" time is changed to at least double what was set with the automatic setting. Also change the clip time to the same number as the clip duration.

Let the clips come around again and pass through the antennas, if the clips pass without triggering the metal detector then everything is ready. If the detector trips on the clips then increase the "clip duration" to allow the clips to pass over the down stream idler roller, also change the "clip time" to the same number as clip duration and reduce the "clip sensitivity" by a few percent.

Manual Setup

Manual Setup is used to fine adjust the clip time and sensitivity. Press down arrow "settings" will appear in the display window. Press enter "sensitivity" will be displayed, press the down arrow 5 times until "setup" is in the display window press enter, "code" will be

displayed in the window. Using the up and down arrow enter the number **3080**. Press up arrow until "3" is displayed press enter, an X will be over the three that was just entered and the cursor will have moved one place to the left and a "0" will be displayed, press "enter". Press the down arrow a couple of times until the number is "8", press "enter". A "0" will be in the display press "enter". The display will have "conveying speed" in the window. Press the down arrow until "clip mode" appears in the window, press "enter". "Single" should be in the display, if "dual" is displayed then use the up or down arrow to change the display to "single", press "enter". Press the down arrow until "clip duration" is displayed and press enter, clip duration with the clip time is displayed use the arrow buttons to change the clip duration to the desired time.

Clip time is the length of time it takes the clips to pass from the clips sensor which is in front of the first upstream idler roller until the first downstream roller is passed. This time can be determined with a stop watch, enter this time into the clip duration and press "enter".

Clip sensitivity needs to be adjusted so that the clips pass without the detector tripping. After clip duration has been entered press the down arrow and clip sensitivity is the next menu item, press "enter". Clip sensitivity will be displayed adjust the sensitivity percentage by using the arrow buttons. Start the clip sensitivity at 50%. If the clips trip the detector then the sensitivity is too high and will need to be reduced. If the detector does not trip then the sensitivity can be increased. Keep increasing the sensitivity until the detector trips on the clips. Once this happens lower the sensitivity a little at a time until the clips pass. If a target piece of metal is placed on the clips on the clips the combined clip and metal signals should trip the detector.

Clip display time is the length of time the words "clip mode" is displayed in the window. This is just a display function and does not affect the clip transition time or sensitivity. This time should be set to the same time as the clip duration time. The clip display time is the next menu item after the clip sensitivity.

Dual Clip Operation (if applicable)

Dual clip mode is used on slow moving conveyors and the clip transition is longer than the 30 seconds the standard clip time that can be programmed for. The other uses are on variable speed conveyors or conveyors that start and stop. Dual clip mode should be set up at the factory. If it is a retrofit then call the factory to get help with the setup because the dual clip mode function needs to be set up in the software.



Setting up sensitivity is the same as for single clip.

Automatic dual clip setup is the same as automatic set up; with one exception in automatic mode the only thing that is displayed is the percent of sensitivity and clip sensitivity is automatically changed. No clip time is displayed because clip time is irrelevant since dual clip is not a time function.

Direct and Timed Out setup

Direct Out activates when metal is detected. It can be programmed for manual or automatic reset. With automatic reset selected the output stay activated for about 1 second then it is reset. In manual mode once the output is activated it will stay activated until the “reset” button is pressed.

Changing Direct Out Setting

Press down arrow “settings” will be in the display window press “enter”. The next window will show “sensitivity” press the down arrow until “direct out” is in the display window, press “enter”. By using the arrow buttons the manual or automatic reset options can be selected, once the selection is made press the “enter” button to set the selection.

Changing Timed Out Settings

Timed output can be set for automatic or manual reset. In automatic reset mode the timed output can be adjusted to allow the output to be delayed up to 30 seconds before activation. Once the timed out is activated it can be held activated for up to 30 seconds. If the time out is programmed for manual reset then it will stay activated until the “reset” button is pressed.

Programming the Timed Output

Press the down arrow, “settings” will be displayed press “enter”. “sensitivity” will be in the display window. Press the down arrow button until “timed out” is displayed, press “enter”, “timed out” will be in the display window with “automatic or manual” under, if in manual mode use arrow keys to change to automatic, press “enter”. Press the up arrow to get to “reject duration” menu option, press “enter”. Using the up and down arrow keys select the reject duration time. This will make the output active for whatever time interval that is set, .05 to 30 seconds, press “enter”. Next press the down arrow until “reject del. time” is in the display, press “enter”. Set the delay before activation time by using the up and down arrow keys, set between 0 to 30 seconds, press “enter”.

Marking Device Calibration

There are two marking devices to choose from: Spray Marker which uses a colorant dye sprayed onto the product to identify the location of metal and the Flag Drop Marker that uses a magnetic tag that is dropped on the product to identify the location of the metal. Both marking devices re set up in the same manner.

The marking devices are connected to the Timed Output. Set the timed out to “automatic reset”. Set “reject delay time” to 1 second. Set “reject duration” to (1 second Spray Marker) or (.05 seconds for Flag Drop Marker). The “reject delay time” of 1 second is the starting point and will need to be adjusted to allow for correct marking of the metal. Place a piece of tramp metal on the belt at normal belt speed. As the piece of metal passes through the antennas the detector will trigger and the timed output “reject delay time” is activated. After 1 second the spray marker will spray for 1 second. Or the flag marker will drop the flag. The object is to get the spray mark or the flag to hit the metal on the belt. If the mark is before the metal then the time delay needs to be increased. If the mark is behind the metal then the time delay needs to be decreased. With the spray marker the metal should be in the center of the spray area and with the flag drop marker the flag should hit the metal on the belt.

The flag drop marker has two error function indicator. At turn on if the is missing a flag a flashing “F” is displayed. If the flag is pulled out or fell out of its holder during operation then a flashing “E” is displayed. Both of these error conditions are corrected by placing a flag in the holder.

Menu Tree (Operator Level 1)

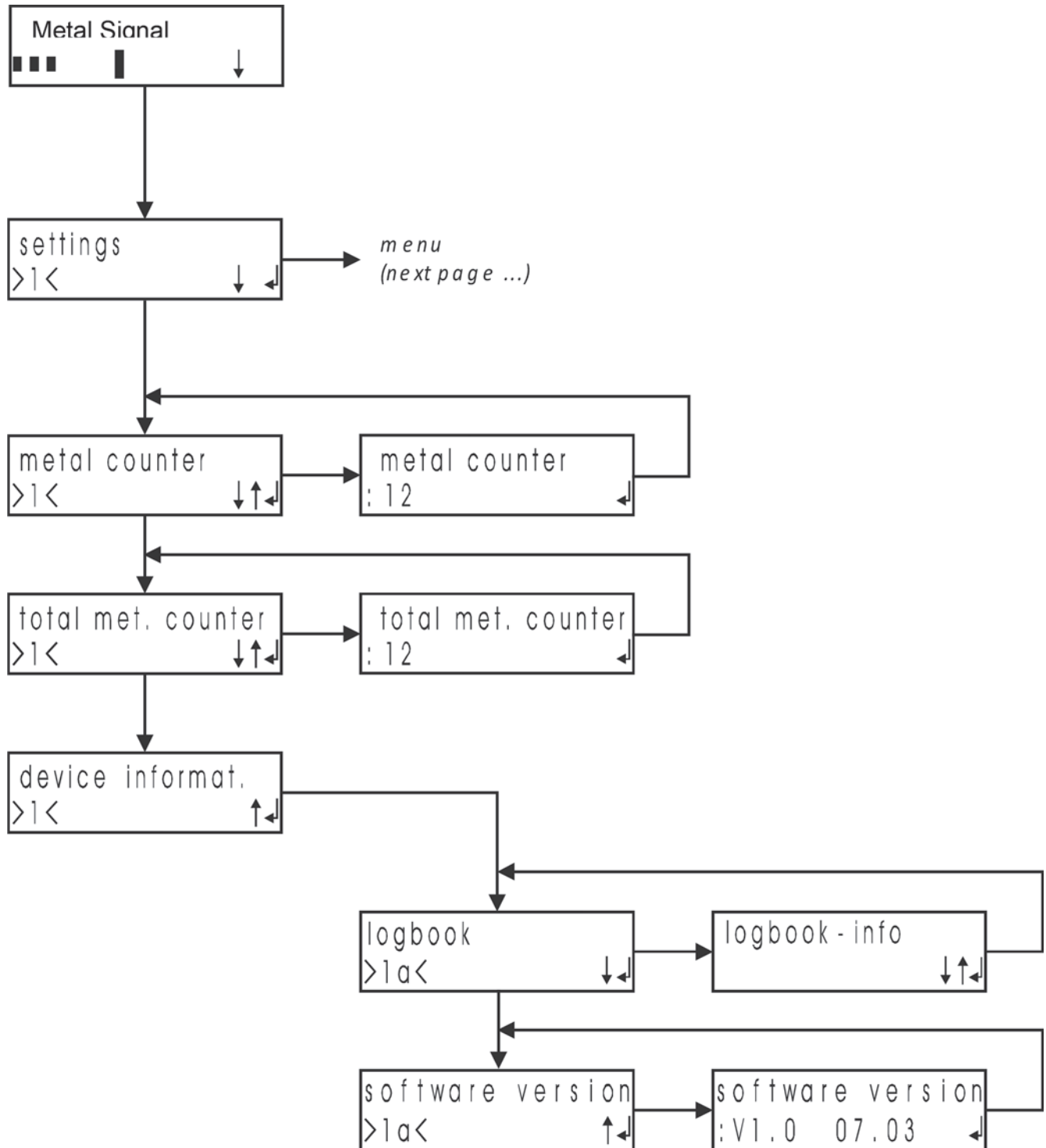

Settings

```
settings  
>1<            ↓ ↑ ↵
```

Pressing the ↵ button selects the submenu **“Settings”** Further submenus are explained below.

Metal Counter

```
metal counter  
>1<            ↓ ↑ ↵
```

Pressing the ↵ button selects the submenu **“Metal counter”**.

```
metal counter  
: 5            ↵
```

This displays the number of metal events. Pressing the >> RESET << button resets the metal counter.

Note: The value is automatically saved when the machine is switched off.

Total Metal Counter

```
total met. count  
>1<            ↓ ↑ ↵
```

Pressing the ↵ button selects the submenu **“Total metal counter”**.

```
total met. count  
: 5            ↵
```

This displays the total number of metal events. The total metal counter is reset by pressing >> RESET << for longer than 5 seconds.

Note: The value is automatically saved when the machine is switched off.

Device Information

```
device informat.  
>1<            ↑ ↵
```

Pressing the ↵ button selects the submenu **“Device information”**. Further submenus are explained below.

Logbook

```
logbook  
>1a<            ↑ ↵
```

Pressing the key selects the submenu **“Logbook”**. Generally 2 screens (2 pages) are used for creating entries in the logbook.

Example 1: Metal Alarm

```
001< Metall
22.05. 07:46  ↑↓
```

```
001< Signal: 0.35
MCnt: 009      ↓↑↓
```

Screen 1: Message text for metal alarm:

001< Entry number, example no: 001
Metal Message text
22.02. 07:46 Date and time of event
 Press **UP** key to move to screen 2

Screen 2: Information about message text:

Information and tips relating to message text on screen 1 are shown here,
001< Entry number (example no: 001)
Signal 1. Parameter: Signal strength with 0.35V [V_{ss}]
 2. Parameter: Metal Count: 9. Metal event
 Press **UP** key to move to next screen or **DOWN** key to
 change to previous menu

Example 2: Error Message

```
005< tran. inter.
23.05. 09:57  ↑↓
```

```
005< ---
                  ↓↑↓
```

Screen 1: Message text for error message:

005< Entry number, example no: 005
tran. inter. Message text: Transmitter break in connection
23.05 09:57 Date and time of event
 Press **UP** key to move to next screen
 Press ↓ key to change to previous menu

Screen 2: Information about error message:

Information and tips relating to error text on screen 1 are shown here,
005< Entry number (example no: 005)
--- 1. Parameter: - - - (no other parameters available)
 2. Parameter:
 Press UP key to move to next screen or ↓ key to
 change to previous menu

```
no entry avail.!
```

This message appears when there is no entry in the logbook or the logbook has been “emptied” using the reset function in the “System functions” menu.

Examples of Logbook Entries

Screen 1 Line 1	Screen 1 Line 2 Day:Month Hour:Minute	Screen 2 Line 1	Screen 2 Line 2	Explanation
power off	10.10 13:13	---	---	Machine switched off
power on	xx.xx xx:xx	---	---	Machine switched on
swing away	xx.xx xx:xx	---	---	Sensor 3 (transmitter coil swing away)
sys-disable	xx.xx xx:xx	---	---	System disabled - excess voltage detected
metal	xx.xx xx:xx	Sig: x.xx	MCnt: xxx	Metal alarm Sig: Metal signal [V_{SS}] MCnt: Current metal count
clip dur	xx.xx xx:xx	---	---	Learnt with metal: Clip not detected by coil
clip sensor	xx.xx xx:xx	---	---	Sensor 1 / 2 (Signal duration too long)
sw aw-dur.	xx.xx xx:xx	---	---	Sensor 3 (transmitter coil swung away for longer than 1 min)
+24V faulty	xx.xx xx:xx	---	---	Power supply +24V faulty
+24V ampl.	xx.xx xx:xx	---	---	Power supply +24V output stage faulty
-24V faulty	xx.xx xx:xx	---	---	Power supply -24V faulty
-24V ampl.	xx.xx xx:xx	---	---	Power supply -24V output stage faulty
tran. overl.	xx.xx xx:xx	---	---	Transmitter overloaded
tran. inter.	xx.xx xx:xx	---	---	Transmitter break in connection
tran. volt.	xx.xx xx:xx	---	---	Transmitter voltage above max set transmitter voltage
no signal	xx.xx xx:xx	---	---	After switching on: no signal available
rec. inter.	xx.xx xx:xx	---	---	Receiver break in connection
wrong anal.	xx.xx xx:xx	---	---	Wrong signal analyzer set in menu or plugged into the board

INFORMATION

Max number of logbook entries: 100 entries (non-permanent memory is lost when powered down, network standard time: 1.1.2000 00:00:00)

Software Version

```
Software Version
>1a<          ↑↓
```

Press \downarrow to select submenu "**Software Version**". This displays the current software version.

```
Software Version
:V1.0 07.03   ↓
```

This displays the current software version.
 \downarrow closes the screen.

Menu Tree / Setting Menu (Operator Level 2)

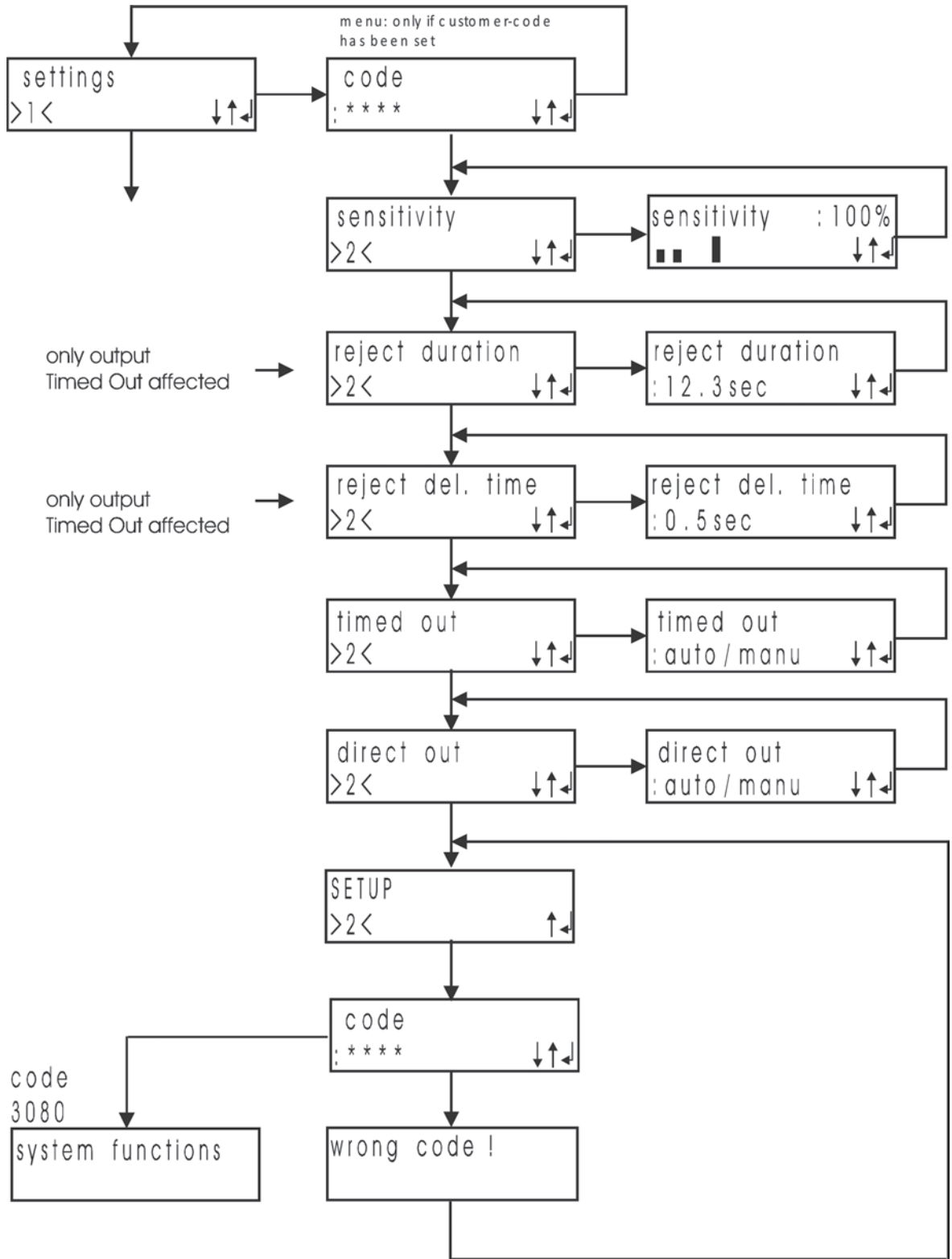

Settings Menu

Code



If customer code has been set, enter CODE
(if customer code not set, this screen will not appear)

Sensitivity



Pressing the ↵ key selects the submenu “**Settings**”. This is where scanning sensitivity for the current product is set or adjusted.



Sensitivity can be adjusted between 1 and 100% using the **UP / DOWN** keys. Press ↵ to confirm the set value.
Metal signal is shown as a bar, overview of sensitivity setting.

Reject Duration



Pressing the ↵ key selects the submenu “**Reject duration**”. This is for setting and adjusting the activity duration of the switching outputs.



Reject duration can be adjusted between 0.05 seconds and 30.0 seconds using the **UP / DOWN** keys. Press ↵ to confirm the set value. This value is not relevant if manual reset mode is selected.

Note: This submenu affects only the relay output >> Timed Out <<.
If the Timed Out output is set to manual this submenu will not appear.

Reject Delay Time



Pressing the ↵ key selects the submenu “**reject delay time**”. This is for setting and adjusting the time or distance between metal detection and activation of the switching outputs.



Reject delay can be adjusted between 0.00 seconds and 30.0 seconds using the **UP / DOWN** keys. Press ↵ to confirm the set value.

Note: This submenu affects only the relay output >> Timed Out <<.

Timed Out

```
timed out
>2<      ↓↑↵
```

Pressing the ↵ key selects the submenu “**Timed out**”. This position determines whether the metal outputs should be reset manually or automatically (after preset reject duration).

```
timed out
: AUTO/MANU  ↓↑↵
```

Use the **UP / DOWN** keys to select the type of RESET: “**AUTO**” or “**MANUAL**”. Use the ↵ key to confirm the setting.

Direct Out

```
direct out
>2<      ↓↑↵
```

Pressing the ↵ key selects the submenu “**Direct out**”. This position determines whether the metal outputs should be reset manually or automatically (with fixed setting of reject duration of 0.5 secs).

```
direct out
: AUTO/MANU  ↓↑↵
```

Use the **UP / DOWN** keys to select the type of RESET: “**AUTO**” or “**MANUAL**”. Use the ↵ key to confirm the setting.

Set up

```
SETUP
>2<      ↑↵
```

Pressing the ↵ key selects the submenu “**Setup**”.
Entering pre-determined, fixed code numbers allows access to other settings menus.
Code no.: 3080, Operator Level 3, System functions

```
code
: * * * *  ↓↑↵
```

code3080

```
system functions
```



Menu tree / System functions (Operator level 3)

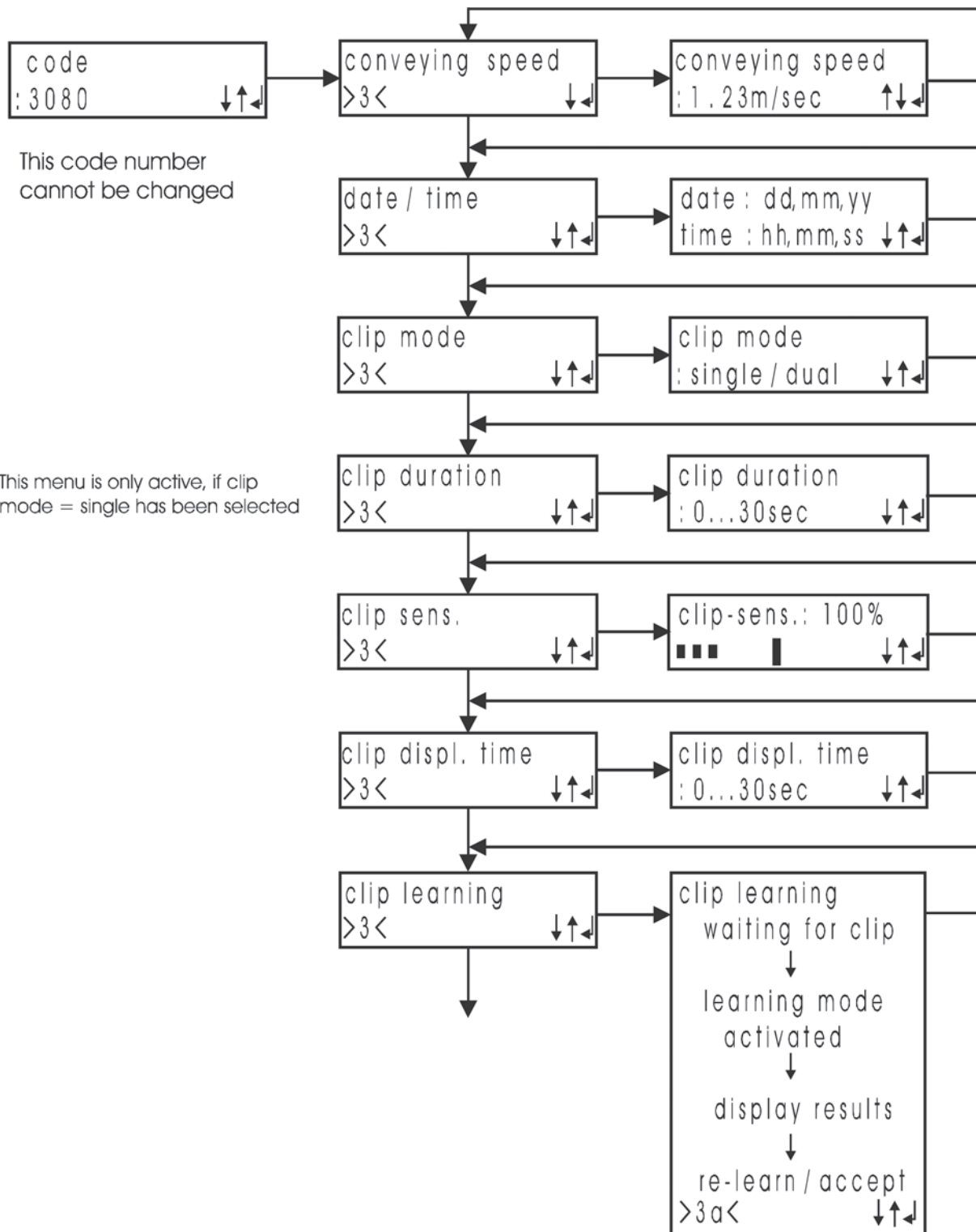

Continued from previous page

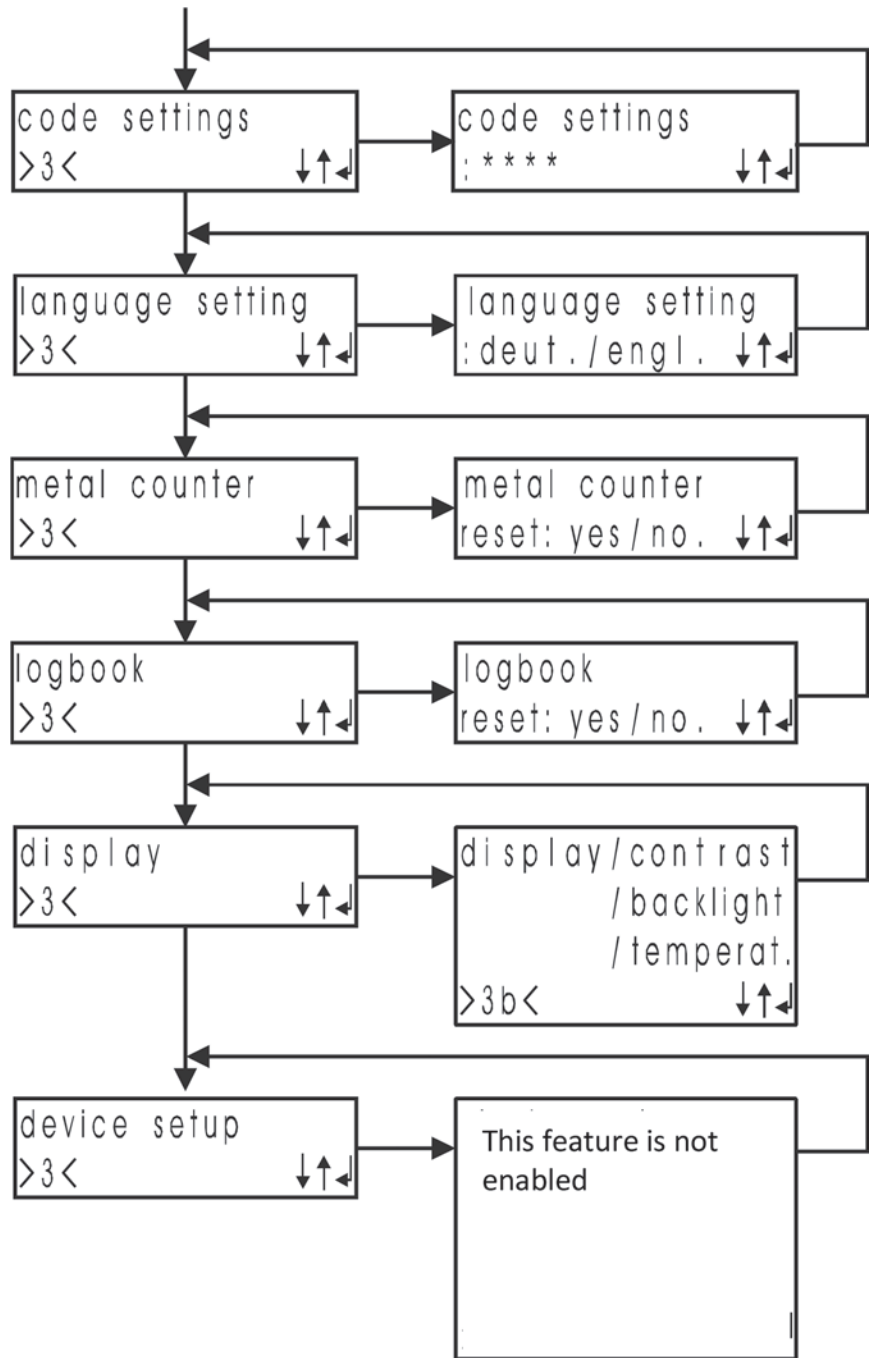

Settings Menu

Conveying Speed

```
conveying speed
>3<           ↓ ↵
```

Pressing the ↵ key selects the submenu “**Conveying speed**”.

```
conveying speed
: 1.23m/sec   ↓ ↵
```

Conveying speed can be adjusted between 0.05m/sec and 15m/sec using the **UP / DOWN** keys. Press ↵ to confirm the set the value.

Date / Time

```
date / time
>3<           ↓ ↵
```

Press ↵ to select the submenu “**Date / Time**”.

```
date: dd, mm, yy
time: hh, mm, ss ↓ ↵
```

Use the **Down** key to select the year (yy) first. Press ↵ to change to month (mm) and day (dd). Next, set hours (hh), minutes (mm) and seconds (ss).

Change the values by pressing the **UP or DOWN** keys. Press ↵ at the end to confirm date and time setting.

Clip Mode

```
clip mode
>3<           ↓ ↵
```

Pressing the ↵ key selects the submenu “**Clip Mode**”.

```
clip mode
: single / dual ↓ ↵
```

Use UP / DOWN keys to switch between clip mode single or clip mode dual. Use the ↵ key to confirm the setting.

Note: Clip mode SINGLE means that only one clip detector is available to switch the system to clip mode (lower sensitivity), and the detector will return to normal operation after the set "clip time" has passed.

Clip mode DUAL means that two clip detectors are available, typically used for variable speed belts or belts that start/stop frequently the first clip detector switches the system to clip mode (lower sensitivity), the second clip detector returns the sensitivity to normal system operation.

Clip Duration

```
clip duration
>3< ↓↑↵
```

Press ↵ to select submenu “**Clip Duration**”.

```
clip duration
:00.00...30.00sec ↓↑↵
```

A value between 0 and 30 seconds can be set using the **UP / DOWN** keys. Use the ↵ key to confirm the setting.

Note: This submenu will only be displayed in SINGLE clip mode.
Clip duration means: The system is operated with the clip sensitivity setting for the clip duration which is set here. After this time has elapsed the sensitivity for normal system operation is automatically resumed.

Clip Sensitivity

```
clip sensitivity
>3< ↓↑↵
```

Press ↵ to select submenu “**Clip Sensitivity**”.

```
clip- sens.: 0..100%
■ ■ ■ ↓↑↵
```

Clip sensitivity can be adjusted between 1 and 100% using the **UP / DOWN** keys. Press ↵ to confirm the set value.
Metal signal is shown as a bar, overview of sensitivity setting.

Clip Display

```
clip displ. time
>3< ↓↑↵
```

Press ↵ to select submenu “**Clip Display**”.

```
clip displ. Time
:00.00...30.00sec ↓↑↵
```

A value between 0 and 30 seconds can be set using the **UP / DOWN** keys. Here the operator can enter a time between 0 and 30 seconds for the duration of the text display
>> CLIP-MODE << (reduced sensitivity).
Use the key to confirm the setting.

Note: This submenu will only be displayed in SINGLE clip mode.
If the set clip duration is shorter than the selected clip display duration, the message >> CLIP MODE<< will appear for as long as the selected display duration.

Clip Learning



Press \downarrow to select submenu “**Clip learning**”.
Select \downarrow to move to next submenu \gg waiting for clip \ll .

Waiting for Clip



Press \downarrow to select submenu “**Waiting for Clip**”.
(When you see the clip coming towards you, Press \downarrow)
Select \downarrow to move to next submenu \gg learning mode activated \ll .

Learning Mode Activated



Press \downarrow to select submenu “**Learning mode activated**”.

The learning mode is automatically activated when the connected initiator detects a \gg Clip \ll :

The following are measured automatically:

1. Clip Duration: Time from detection of clip until clip has passed the coil.
2. Clip sensitivity: Reduced value for sensitivity of the system during clip phase, so that this clip is not detected by the coil as metal.

Display: Received Values

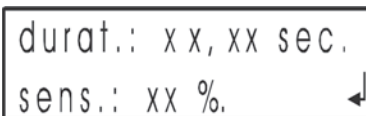

This menu is displayed automatically after a learning process.

It shows the measured time: Clip Duration [in sec]
and measured sensitivity: Clip Sensitivity [in %]

Note: In clip mode:
SINGLE
DUAL

is displayed:

CLIP TIME [in sec] and sensitivity [in %] is displayed

Only sensitivity [in %] is displayed because dual clip mode is not a time based function. When the first clip detector detects a metallic repair clip, it turns on clip mode, when the clip passes the second clip detector it returns the metal detector to normal operation.

Display: Relearn or Accept Values



This menu “**Re-learn or accept**” is displayed after the received values are shown.

Press the ESC key to start the learning process again
(Menu selection: \gg Waiting for clip \ll).

Press \downarrow to accept the learned values.

Password / Code setting

```
code settings
>3<      ↓↑↵
```

Press ↵ to select submenu “**Code Settings**”. A four character password code to password protect the settings screen can be entered here.

```
code settings
: * * * * ↓↑↵
```

Use the **UP / DOWN** keys to select the numbers. Pressing ↵ confirms the selected letter, number or symbol and the cursor then moves to the next position. After the fourth cursor position pressing ↵ accepts the new code.

Language Setting

```
language setting
>3<      ↓↑↵
```

Press ↵ to select the submenu “**Language setting**”. This is for setting the appropriate language for the country of operation.

```
language setting
:deut./engl. ↓↑↵
```

Use the **UP / DOWN** keys to select the appropriate language. Use the ↵ key to confirm the setting.

Reset Metal Counter

```
metal counter
>3<      ↓↑↵
```

Press to select the submenu “**Metal counter**”. This resets both metal counters in the main menu.
(> Metal count < and > Total metal count <).

```
metal counter
reset: yes/no ↓↑↵
```

Use the **DOWN** key to activate reset. Use the ↵ key to make a selection.

Reset Logbook

```
logbook
>3<      ↓↑↵
```

Press ↵ to select the submenu “**Logbook**”. The logbook can be reset in > Main menu / Machine Information <.

```
logbook
reset: yes / no  ↓↑↵
```

Use the **DOWN** key to activate reset. Use the ↵ key to make a selection

Display

```
display
>3<      ↓↑↵
```

Press ↵ to select the submenu “**Display**”. This is where various display parameters are adjusted.

Display Contrast - (Only changes LCD display, never VFD (blue) does not require adjustment)

```
display contrast
>3b<      ↓↵
```

Press ↵ to select the submenu “**Display Contrast**”. This is where the contrast of the display is adjusted.

```
display contrast
: 5        ↓↑↵
```

Use the **UP / DOWN** keys to adjust the display contract between 0 and 99. Use the key to confirm the setting. The contrast values provide a guide only, fine-tuning may be necessary to improve legibility of the characters.

Display Backlight - (Only changes LCD display, never VFD (blue) does not require backlight)

```
displ. backlight
>3b<      ↓↑↵
```

Press ↵ to select the submenu “**Display Backlight**”.

```
displ. backlight
: interval  ↓↑↵
```

Use the **UP / DOWN** keys to set backlighting to always on or intermittent. Intermittent mode means that the backlight will remain on for approx 30 seconds once the key is pressed. Use the ↵ key to confirm the setting.

Display Temperature

```
disp. temperatur
>3b<      ↑↵
```

Press ↵ to select the submenu “**Display temperature**”.

```
disp. temperatur
temp.: 30 °C  ↵
```

The temperature shown refers to temperature inside the housing or on the display. Necessary for adjusting automatic display contrast (only used for LCD screen)

Errors and Fault Rectification

i If you have any questions, please call and have the serial number available!

Error Messages

When an error message is detected the red "Fault" LED on the operator panel flashes and the fault relay trips out. The appropriate error will be shown on the screen.

Transmitter monitoring - Part 1

This message is displayed if the transmitter signal is not detected or the connection to the detector is broken.

Error Message	Possible Causes	Action
transmitter overloaded!	Transmitter cable to detection coil (or transmitter coil within detector) has short circuit.	Disconnect transmitter cable at the detector and measure with Ohm meter: replace if necessary.

Error Message	Possible Causes	Action
transm. connect. interrupted!	Transmitter cable to detection coil (or transmitter coil within head) is interrupted.	Check transmitter cable for breaks and repair, or replace, if necessary. Check transmitter cable plug and socket connections, remove and reinsert if necessary.

Transmitter monitoring – Part 2

This message is displayed when the transmitter signal from the detection head exceeds the set threshold value (max transmitter voltage).

Error Message	Possible Causes	Action
transmitter - voltage?	Transmitter pulse duration is too long or frequency too low or selected threshold >> Max transmitter voltage << is too low	In >> System Parameters << menu correct Start Transmit and End Transmit or correct frequency or adjust >>Max transmitter voltage <<

Monitoring of the receiver

This message is displayed when the connection to the receiver coil is interrupted.

Error Message	Possible Causes	Action
connection to detection coil?	Receiver cable to detection coil (or receiver coil within head) is interrupted.	Check receiver cable for breaks and renew if necessary. Check receiver cable plug and socket connections, remove and reinsert if necessary.

Monitoring of positive operating voltage

This message is displayed when operating voltage (+ 24V) is faulty

Error Message	Possible Causes	Action
power supply +24V faulty	Power supply +24V faulty Power supply (AC-DC converter) defective	Check power supply and measure with voltmeter if necessary

Monitoring of output transformer at positive operating voltage

This message is displayed when the output transformer (at +24V) is overloaded

Error Message	Possible Causes	Action
power supply +24V to ampl.?	PTC (R105) high resistance or defective T103 has short circuit	Check transmitter level, check pulse duration, measure with voltmeter or oscilloscope

Monitoring of negative operating voltage

This message is displayed when power supply (-24V) is faulty

Error Message	Possible Causes	Action
power supply -24V faulty	Power supply -24V faulty Power supply (AC-DC converter) defective	Check power supply and measure with voltmeter if necessary

Monitoring of output transformer at negative operating voltage

This message is displayed when the output transformer (at -24V) is overloaded

Error Message	Possible Causes	Action
power supply -24V to ampl.?	PTC (R118) high resistance or defective T107 has short circuit	Check transmitter level, check pulse duration, measure with voltmeter or oscilloscope

Monitoring of Swing Away sensor (High Pile Detection)

Note: Functionality is available only if in >> Options << menu the function as Swing Away sensor is connected to Sensor 3.

The message is displayed when the transmitter coil is swung away and a swing away sensor is available
The sensor must deliver a signal for 60 seconds in order to activate the error message

Error Message	Possible Causes	Action
swing-away dur. exceeded 60 sec.	Transmitter coil folded back > Swing Away < sensor defective	Fold back transmitter coil, check sensor and measure sensor signal with voltmeter

Monitoring of signal analyzer

This message is displayed when the signal analyzer plugged into the main board is different to that set up in the menu

Error Message	Possible Causes	Action
wrong signal-analyzer	Signal analyzer plugged into main board is not the same as selected in menu	Change signal analyzer in the main board or select different signal analyzer in menu (system parameters)

Monitoring of clip sensors

This message is displayed when a clip sensor delivers a signal for longer than 10 seconds

Error Message	Possible Causes	Action
clip-head fault	A clip sensor is defective. Clip remains above sensor as a result of belt stop	Inspect clip sensors, check if sensor is faulty (constant LOW level) or if clip is above sensor

Monitoring of clip (Menu: clip learning)

This message is displayed only in >> Clip learning << menu when clip requires more than 15 seconds to be detected by coil

Error Message	Possible Causes	Action
clip-duration exceeded 10sec.	Clip stays where it is as a result of the belt stopping	Ensure belt is running and clips have passed through the detector

Error Message	Possible Causes	Action
clip-sensor signal	Shorted Clip Head or during clip learning the clip is missed and the detector trips on the clip.	Inspect clip sensor and test for proper operation. Check clip sensor alignment and proper distance from belt. If repaired area check the alignment of reference clip and clip sensor.

Undefined activation of switching outputs (Contact Factory)

Possible Causes	Action
Machine incorrectly installed	See "Assembly"
Conveyor belt systems: Certain parts of the conveyor belt are conductive: <ul style="list-style-type: none"> Contaminated with metal (welding spatter, metal chips, abraded material...) Belt junction causing metal alarm to signal even when no product on moving conveyor 	Clean conveyor belt of all residue If necessary replace conveyor belt.
Sensitivity set too high	If necessary reduce sensitivity manually
Metal particles hard to identify due to corrosion or encapsulation	Check processed material carefully, if necessary pass through detector again.
Loose contact at the detector cables	Check connections



APPENDIX A

Control Connection Diagrams

 **DANGER**

All electrical connections should be made with the power off!

 **WARNING**

Please double check all connections before applying power to avoid potential damage to the electronics.

Appendix A: Wiring Diagram

The first drawing shows the electronics as they are wired from the factory. Most wiring will be done to the terminal block TB1. This includes input power, alarms, and interfacing with your plant control system. The antennas, clip detector and swing away switch are wired directly to the appropriate connections on the main board (bypassing TB1)

For every numbered terminal position on TB1 there are 4 terminals. This is to allow for flexibility and ease of use. We try to avoid using more than 1 wire in a terminal if possible, and this design makes that easier. This also means there are extra terminals that you may not use depending on accessories and how you integrate the detector into your plant control system.

The fault relay can be wired to provide a “healthy” signal as well. This relay is shown in the diagrams in the “on – healthy” position. The relay will switch if the metal detector is turned off or has a fault.

The chart below lists how each terminal in TB 1 is used. Please refer to the wiring diagrams for specific connection instructions. If you have any questions, **PLEASE ASK!**

TB 1 Terminal Number

L	Incoming Hot Power - Always Hot
2-3	Switched Hot Power - only hot when detector is turned on
N (4-5)	Incoming AC Neutral Line
6-7	AC Ground (Earth)
8	Normally Open pin - Metal Detected Direct Out Relay (see figure A5)
9	Center Pin - Metal Detected Direct Out Relay (see figure A5)
10	Normally Closed Pin - Metal Detected Direct Out Relay (see figure A5)
11	Normally Open Pin is Closed - Fault Relay (opens when detector has fault or turned off)
12	Center Pin - Fault Relay
13	Normally Closed Pin is Open - Fault Relay (closes when detector has fault or turned off)
14	Normally Open Pin - Metal Detected Programmable Timed Out Relay (Figure A6)
15	Center Pin - Metal Detected Programmable Timed Out Relay (Figure A6)
16	Normally Closed Pin - Metal Detected Programmable Timed Out Relay (Figure A6)
17	Remote Reset
18	Remote Reset Return
19-20	Open - only used with accessories



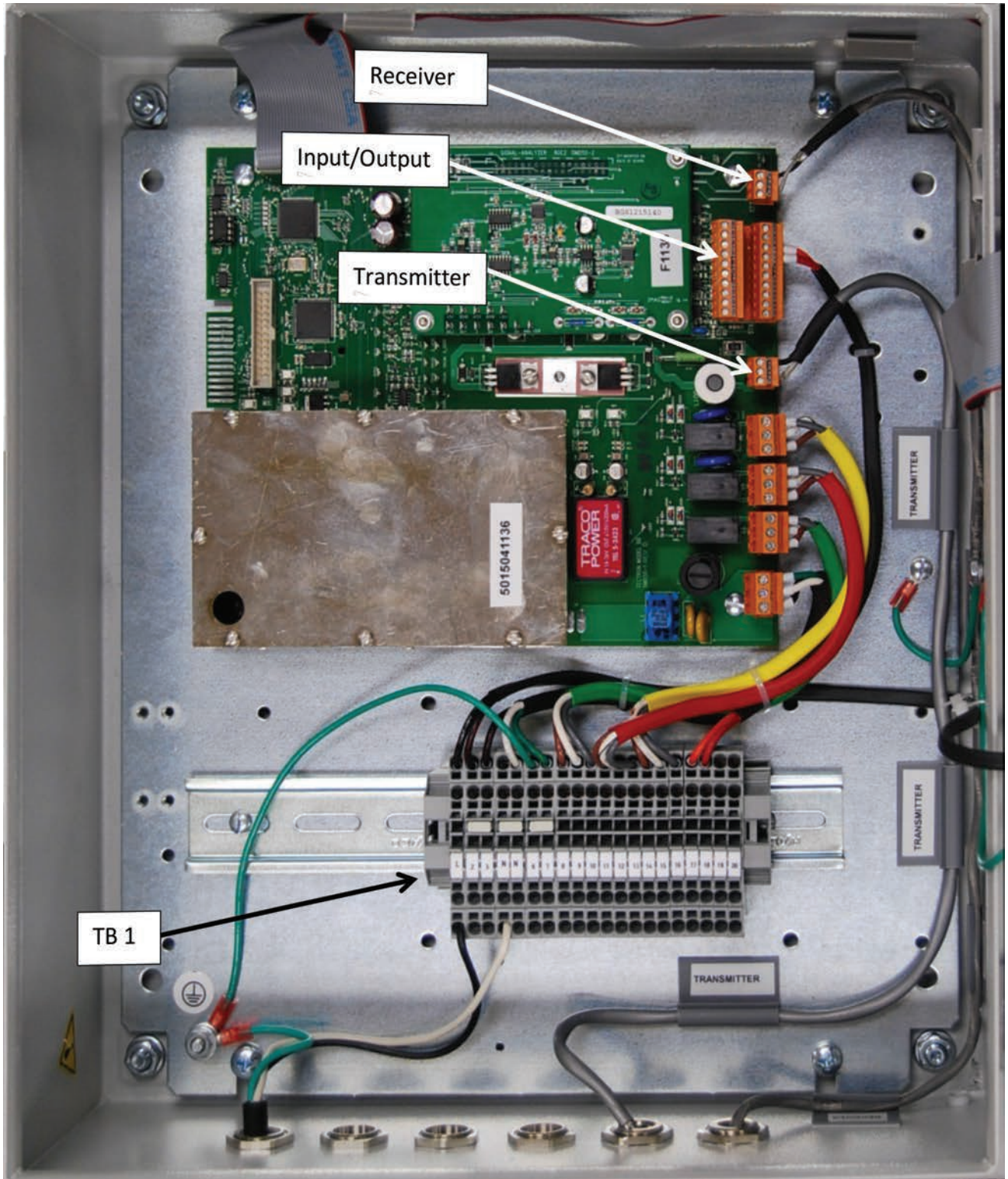

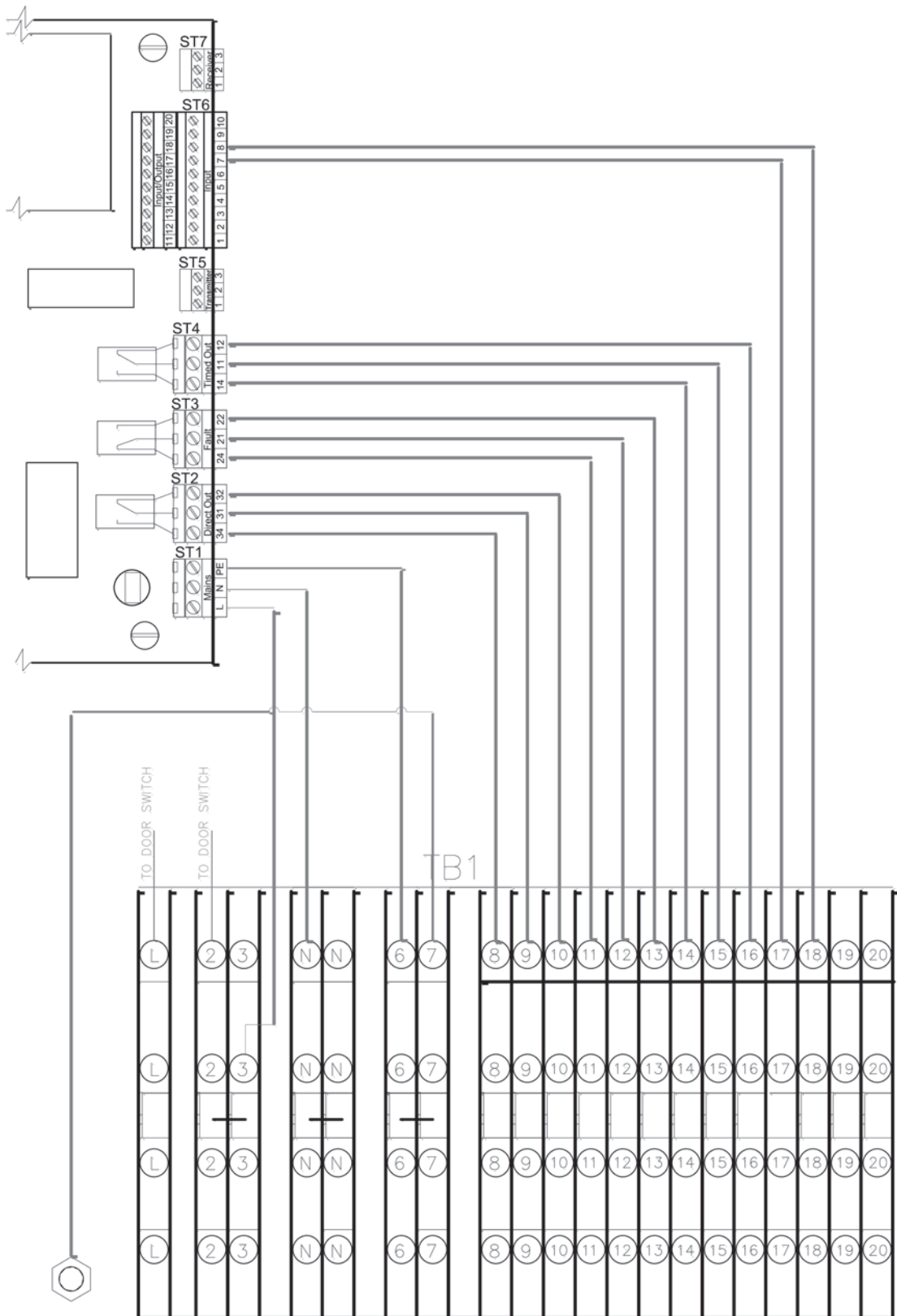

FIGURE A1
Enclosure Diagram - Factoring Wiring



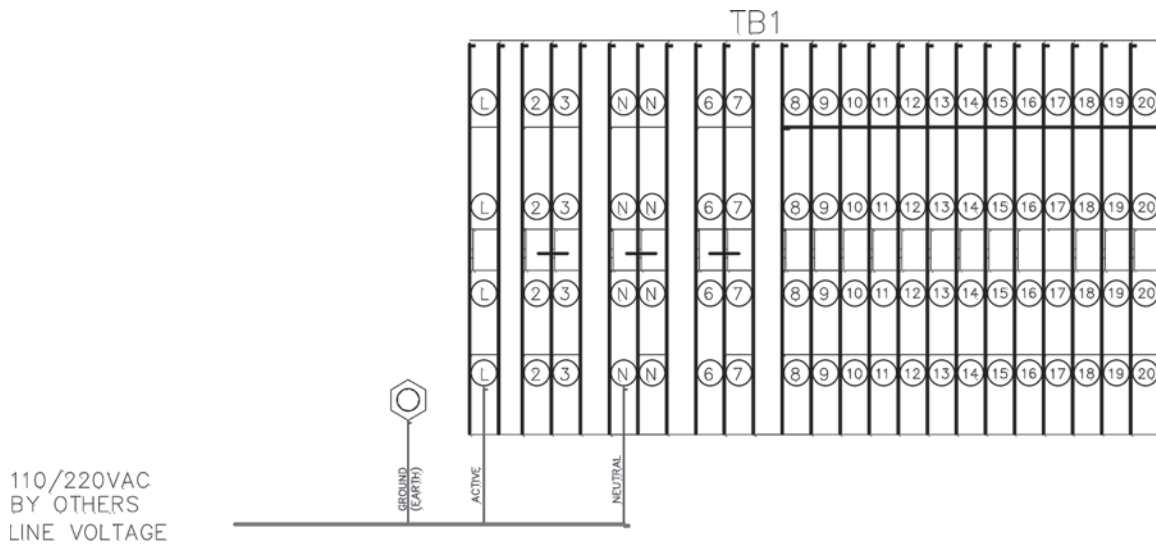

FIGURE A2
Input Power to the Detector

Input Power to the Detector

Active - Terminal 1

Neutral - Terminal N (4 & 5)

Ground - Terminal 6 & 7, Ground

⚠ WARNING

Disconnect switch or circuit breaker is to be included in the building installation. It is to be provided in suitable location that is easily reached and is marked as disconnect for the equipment.

Wiring Incoming Power:

1. Strip outer jacket from power cable approximately 5.5inches (140mm) back from the end.
2. Take the ground wire and shorten it to 3.5inches (90mm) from the end of the jacket.
 - a. Strip 3/8inch (8mm) from the end and add a ground lug.
3. Prepare the “Live” and “Neutral” leads for insertion by tinning the wire to reduce stray strands (only required on multi strand wire).
4. Insert the Live line into the “L” socket on terminal block TB1.
5. Insert the Neutral line into the “N” socket on terminal block TB1.
6. Attach the ground wire lug to the provided PE ground point in the lower left corner of the mounting plate.

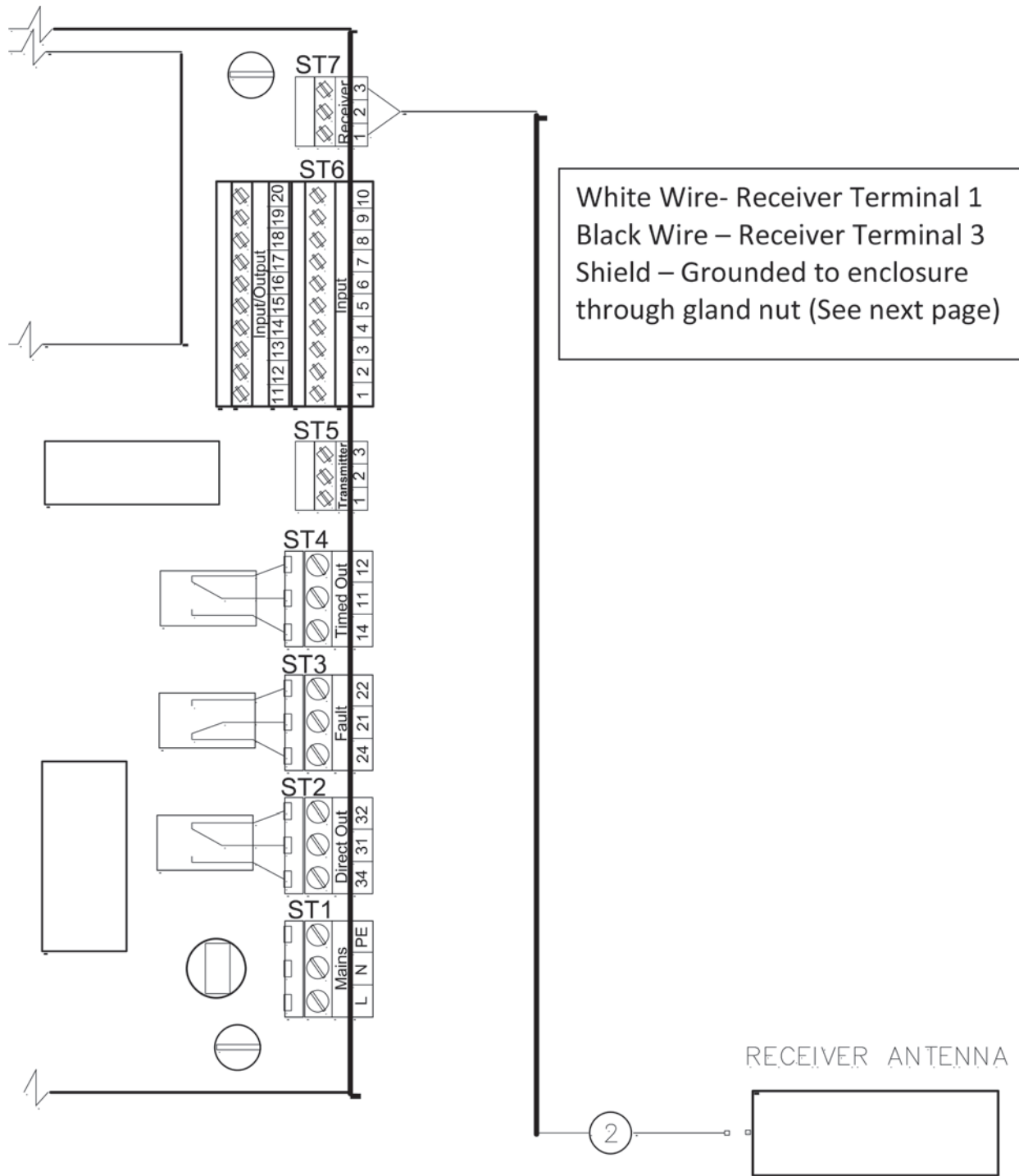

FIGURE A3
Receiver Antenna Connections

Receiver Preparations

Only required when changing cable length!

Noise emission considerations require moving the antenna shield line away from the main board. This is accomplished using EMI shielding gland nuts to ground the shield return to the enclosure. The transmit and receive cables are of different diameters and are required to enter the enclosure through the provided access points to improve noise reduction. The physical layout of the enclosure dictates the lengths of the sections for performing the maintenance on the cables. The process involves removing a section of the outer jacket but leaving the inner shield and drain wire intact. Also the removal of the drain wire from the end of the cable where it is attached to the connector.

Receiver cable

1. Measure and trim 1-1/2" from the end of the cable, exposing the black, clear and shield wires.
2. Measure back from the end of the cable 20-1/2", and mark the cable.
3. Measure an additional 3/8" past the first mark and place the second mark.
4. Cut the jacket along both lines, ensuring the blade does not cut into the shielding.
5. Make a parallel cut along the small section to aid in prying it away from the cable to remove in one piece.

The image below shows a representation of the cutaway with the connector build up using a clear shielded cable for reference.

6. Place the cable through the Yellow gland nut ensuring the bare shield area is retained in the area of the spring and clamps.

The picture below shows the layout of the gland nut to facilitate correct placement of the components.

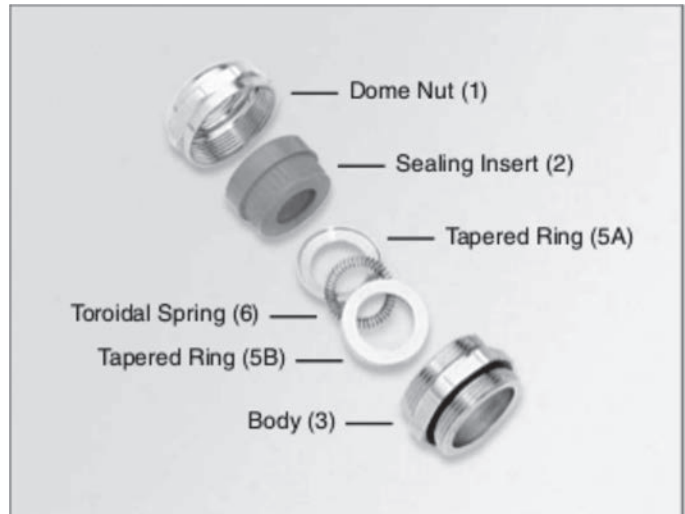

7. Tighten gland nut to ensure the rubber grip seals around the outer jacket.
8. Perform a continuity test from the gland nut to the unjacketed shield drain at the end of the wire to ensure the spring makes good contact for the ground. Once good contact is confirmed, clip the shield drain wire at the end of the cable.
9. Remove the insulation and prepare the black and clear jacketed wires for installation to the receiver plug.

Installation of TOR-SPRING Cord Grips

CONTA-CLIP's unique TOR-SPRING EMI/RFI Cord Grip design featuring the toroidal spring/tapered ring principle ensures a controlled and precise installation onto shielded cables. Installation is simplified and installation time is significantly reduced because only the cable jacket needs to be cut and removed at the Cord Grip attachment point. The cable's braided shield remains intact and is eliminated from the installation procedure. Since the braided shield extends to the termination point, continuous EMI/RFI Performance is guaranteed.

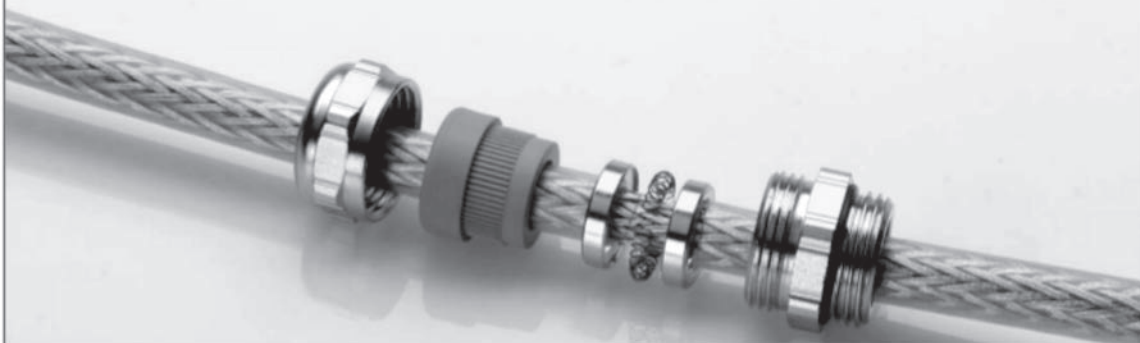

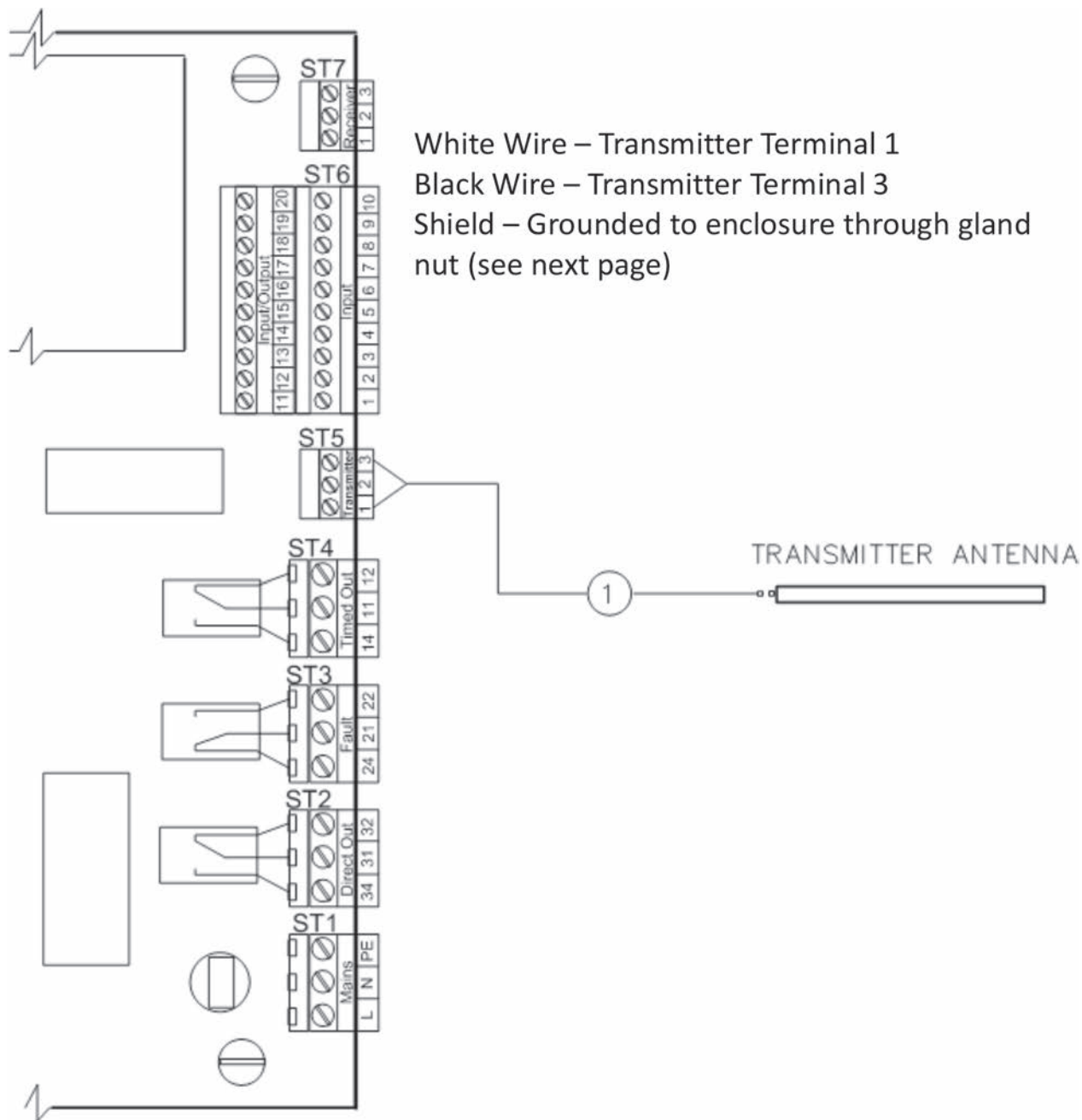

FIGURE A4
 Transmitter Antenna Connections

Transmitter Preparations

Only required when changing cable length!

Noise emission considerations require moving the antenna shield line away from the main board. This is accomplished using EMI shielding gland nuts to ground the shield return to the enclosure. The transmit and receive cables are of different diameters and are required to enter the enclosure through the provided access points to improve noise reduction. The physical layout of the enclosure dictates the lengths of the sections for performing the maintenance on the cables. The process involves removing a section of the outer jacket but leaving the inner shield and drain wire intact. Also the removal of the drain wire from the end of the cable where it is attached to the connector.

Transmitter cable

1. Measure and trim 1-1/2" from the end of the cable, exposing the black, clear and shield wires.
2. Measure back from the end of the cable 18-1/2", and mark the cable.
3. Measure an additional 3/8" past the first mark and place the second mark.
4. Cut the jacket along both lines, ensuring the blade does not cut into the shielding.
5. Make a parallel cut along the small section to aid in prying it away from the cable to remove in one piece.

The image below shows a representation of the cutaway with the connector build up using a clear shielded cable for reference.

6. Place the cable through the white gland nut ensuring the bare shield area is retained in the area of the spring and clamps.

The picture below shows the layout of the gland nut to facilitate correct placement of the components.

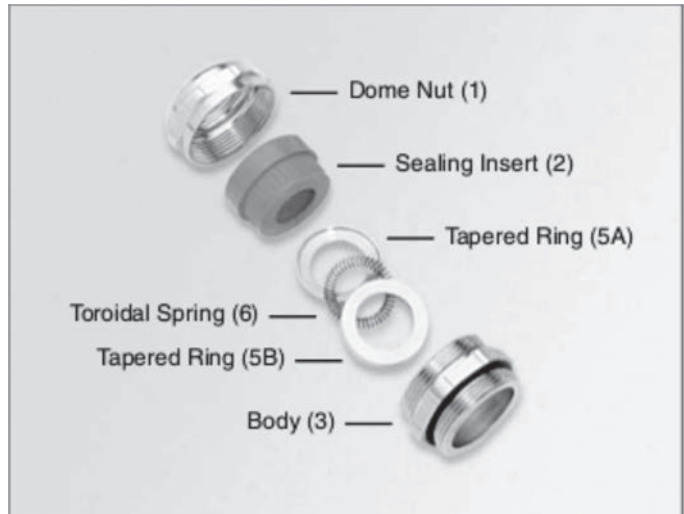

7. Tighten gland nut to ensure the rubber grip seals around the outer jacket.
8. Perform a continuity test from the gland nut to the unjacketed shield drain at the end of the wire to ensure the spring makes good contact for the ground. Once good contact is confirmed, clip the shield drain wire at the end of the cable.
9. Remove the insulation and prepare the black and clear jacketed wires for installation to the transmitter plug.

Installation of TOR-SPRING Cord Grips

CONTA-CLIP's unique TOR-SPRING EMI/RFI Cord Grip design featuring the toroidal spring/tapered ring principle ensures a controlled and precise installation onto shielded cables. Installation is simplified and installation time is significantly reduced because only the cable jacket needs to be cut and removed at the Cord Grip attachment point. The cable's braided shield remains intact and is eliminated from the installation procedure. Since the braided shield extends to the termination point, continuous EMI/RFI Performance is guaranteed.

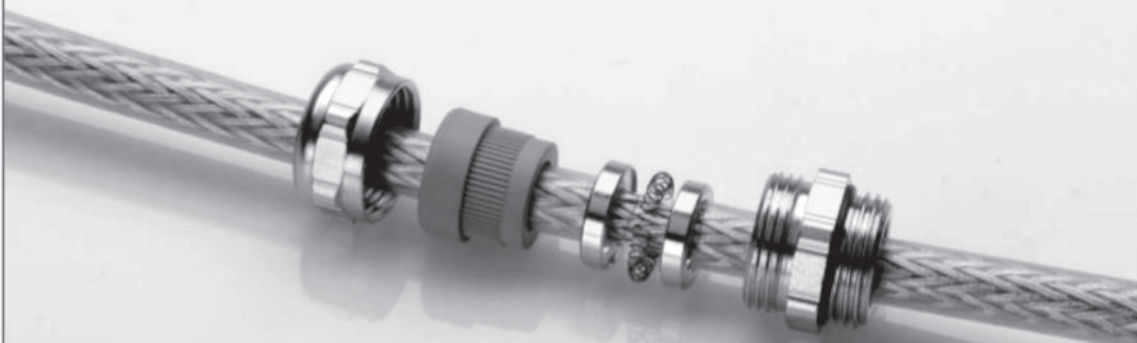

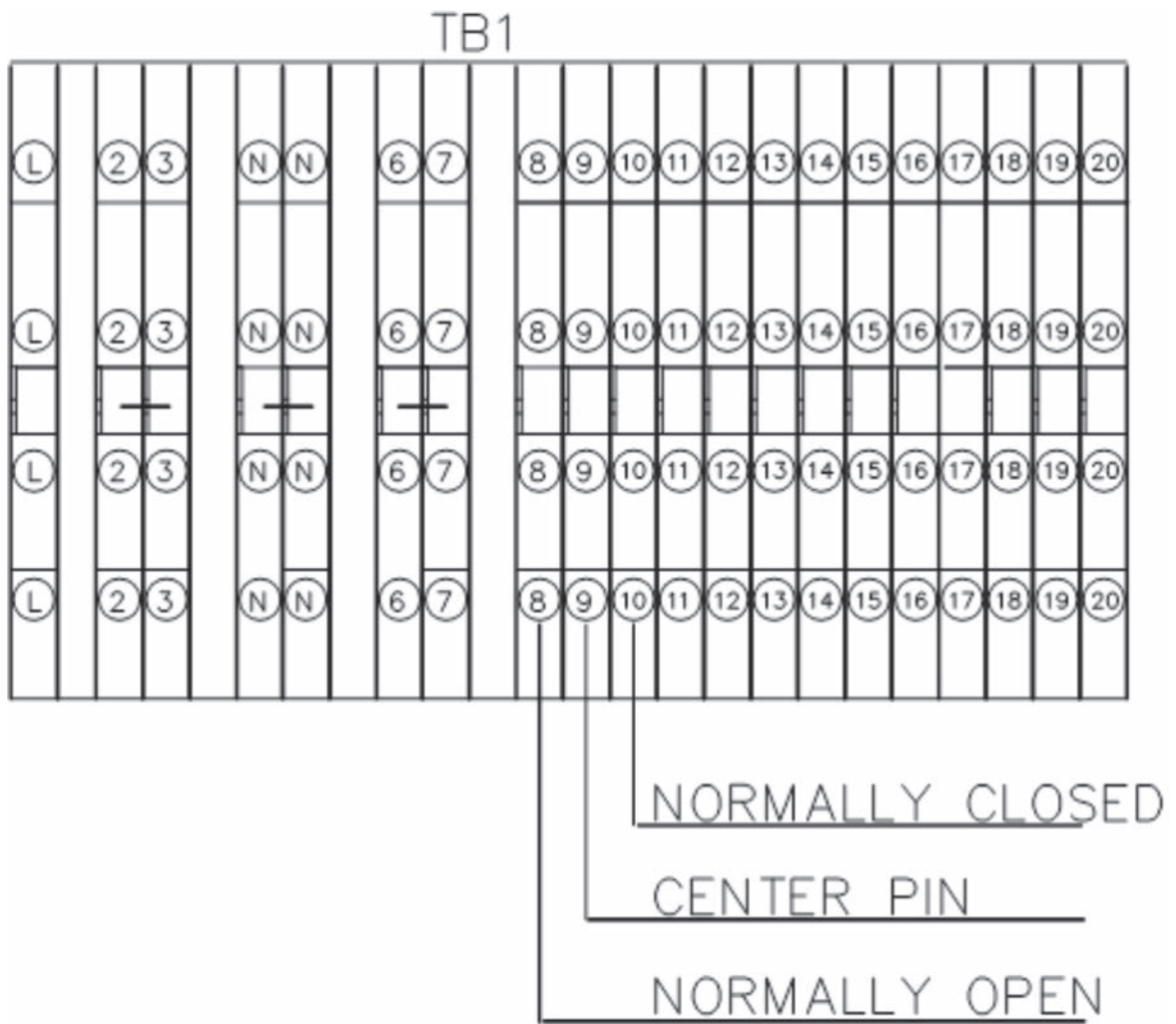

FIGURE A5
Metal Detected - Direct Output Connection

Metal Detected - Direct Output Connection

Terminal 8 - Normally Open Contact (Closes when metal is detected)

Terminal 9 - Direct Output Center Pin

Terminal 10 - Normally Closed Contact (Opens when metal is detected)

This relay (when active via the software) will switch when metal is detected and will remain switched until the metal detector is reset either by turning the reset knob on the door, or closing a connection between the remote reset terminals (TB 1 – Terminals 17 and 18)



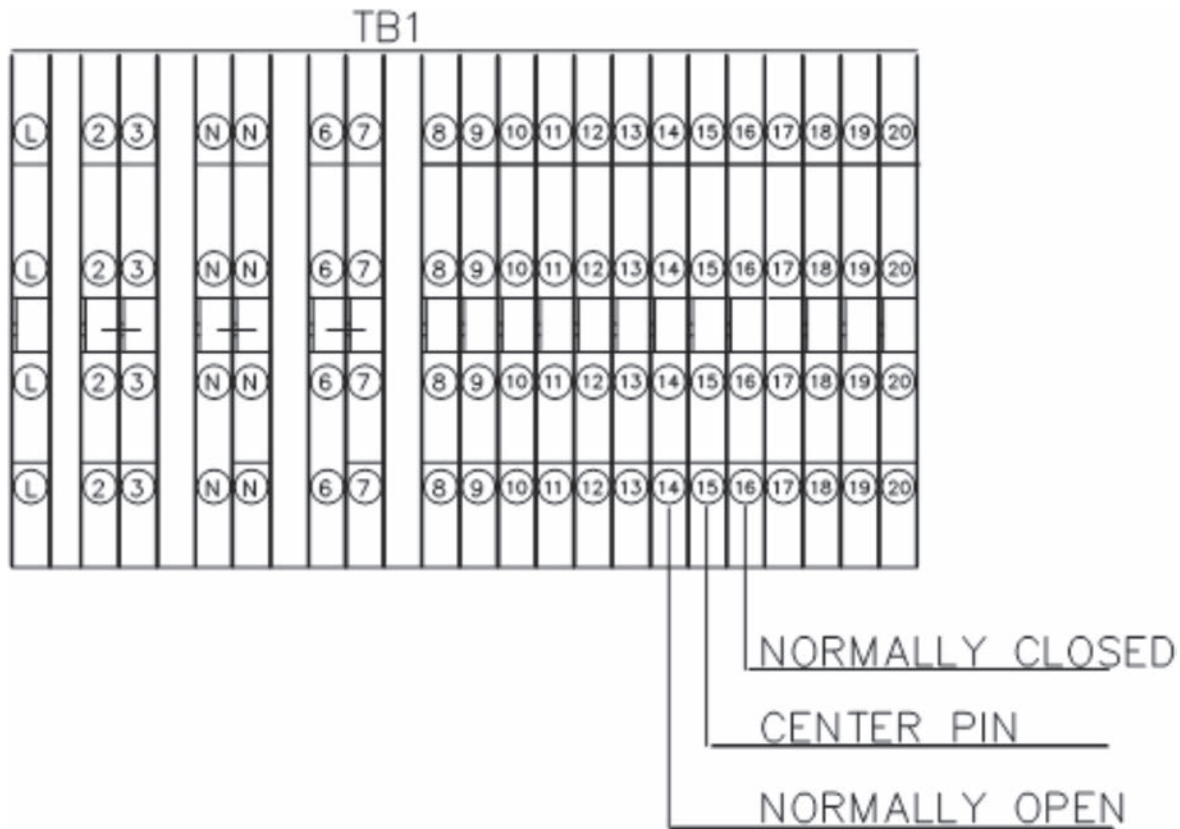

FIGURE A6
Metal Detected - Timed Output Connection

Metal Detected - Timed Output Connection

Terminal 14 - Normally Open Contact (Closes when metal is detected)

Terminal 15 - Timed Output Center Pin

Terminal 16 - Normally Closed Contact (Opens when metal is detected)

The timed output switches when metal is detected. This output is programmable via the software for both delay and duration of the switching when metal is detected. Delay (time between metal detection and relay switching) and duration (duration relay remains switched until timing out and switching back) are programmable from 0-30 seconds in 0.1sec increments. The timed output is commonly used for marking devices and automatic metal diverter systems. Refer to the menu tree on page 30 of this manual for how to program the timed output.

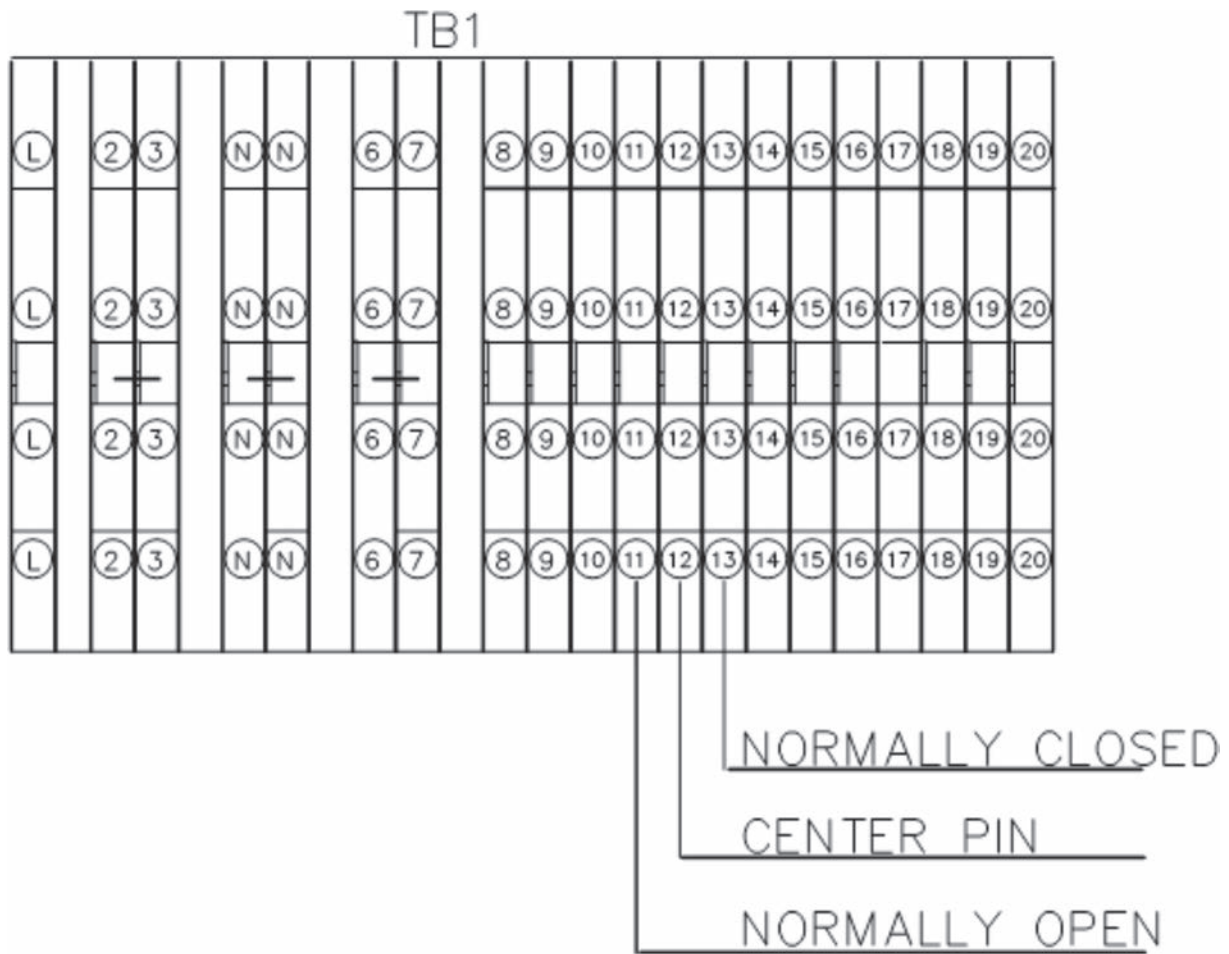

FIGURE A7
Metal Detected - Direct Output Connection

Fault Output

- Terminal 11 - Normally Open Terminal is closed when detector is operating
 (Opens when detector is powered off or a fault condition exists)
- Terminal 12 - Fault Output Center
- Terminal 13 - Normally Closed Terminal is open when detector is operating
 (Closes when detector is powered off or a fault condition exists)

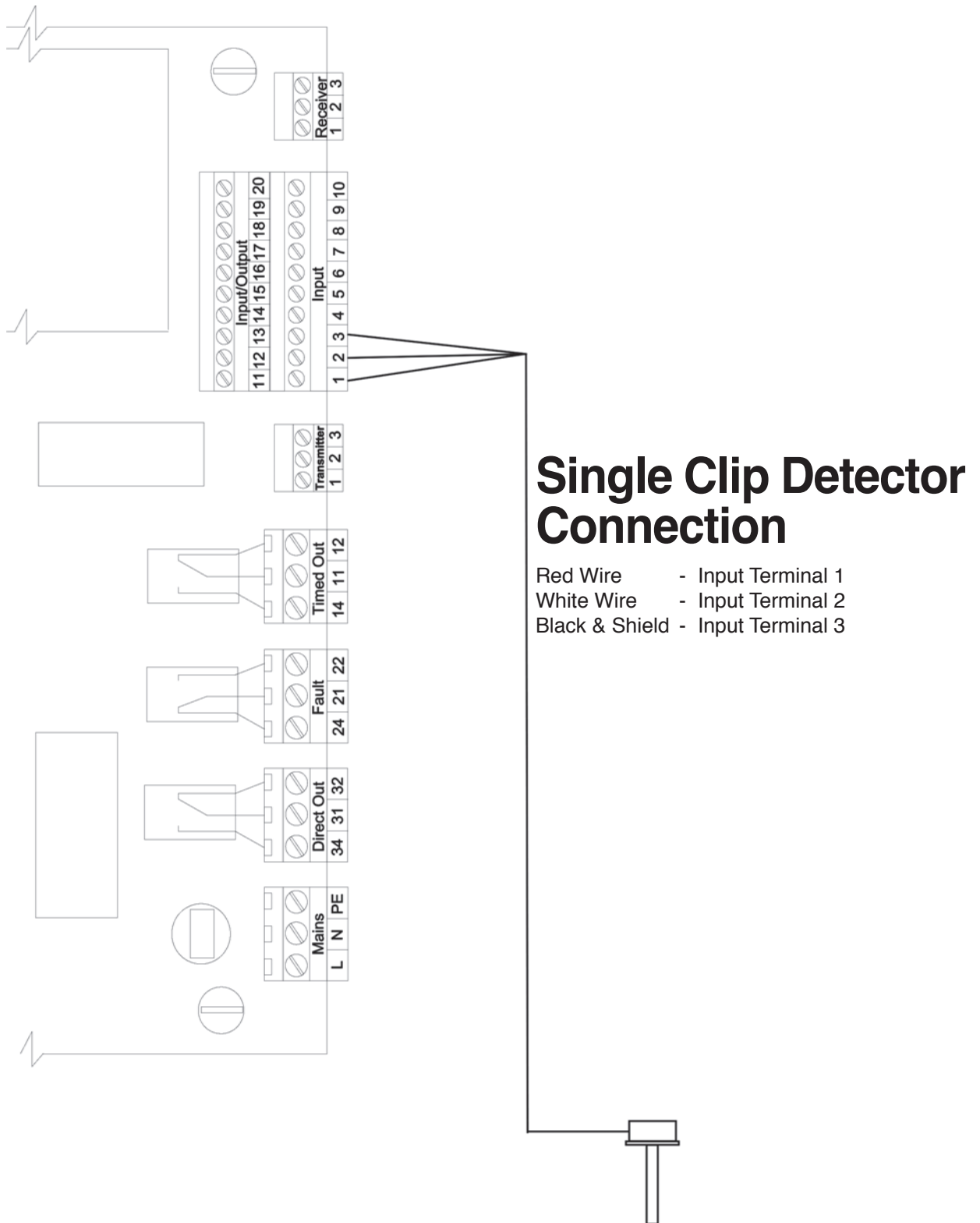

FIGURE A8
 Single Clip Detector Connection

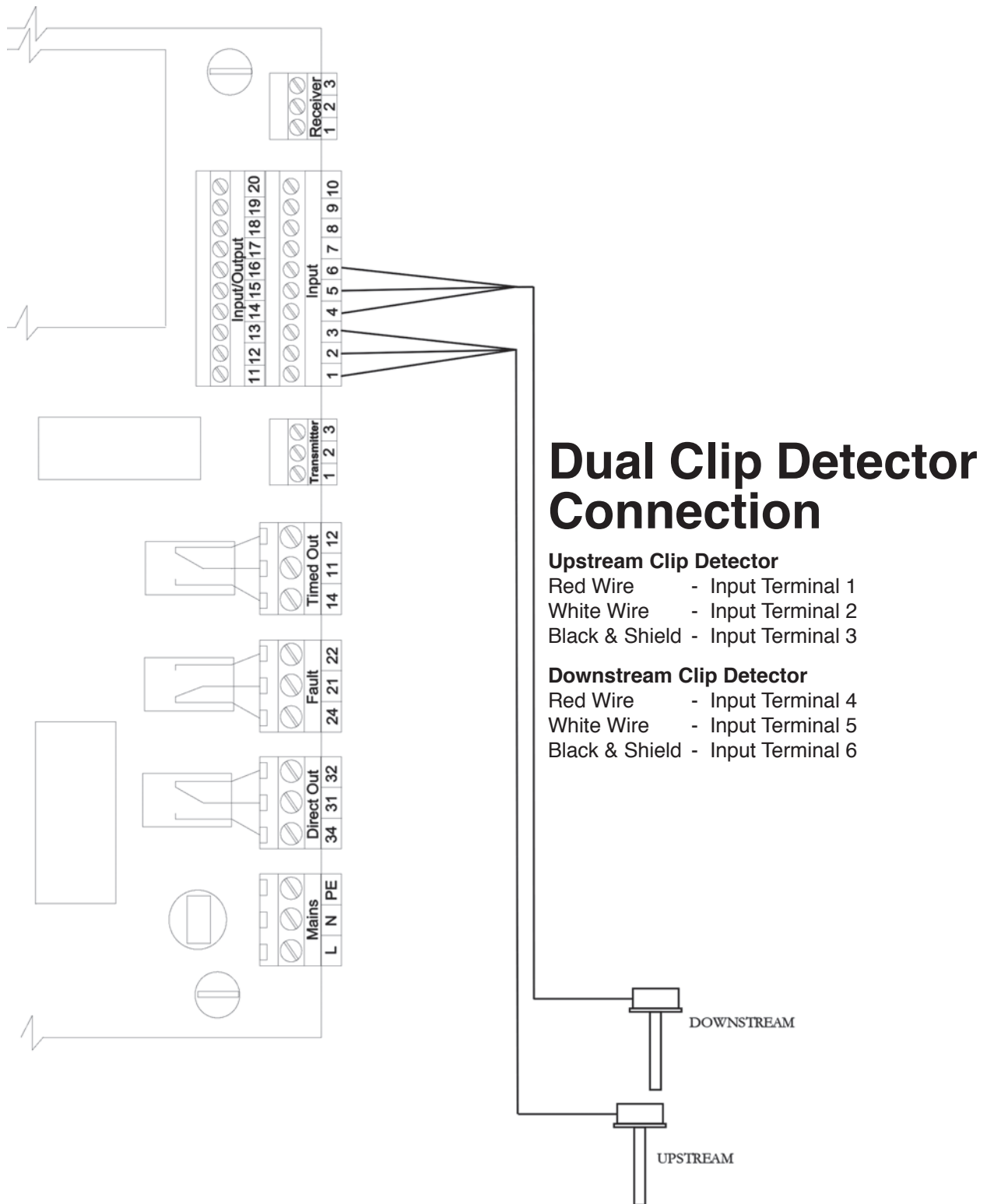
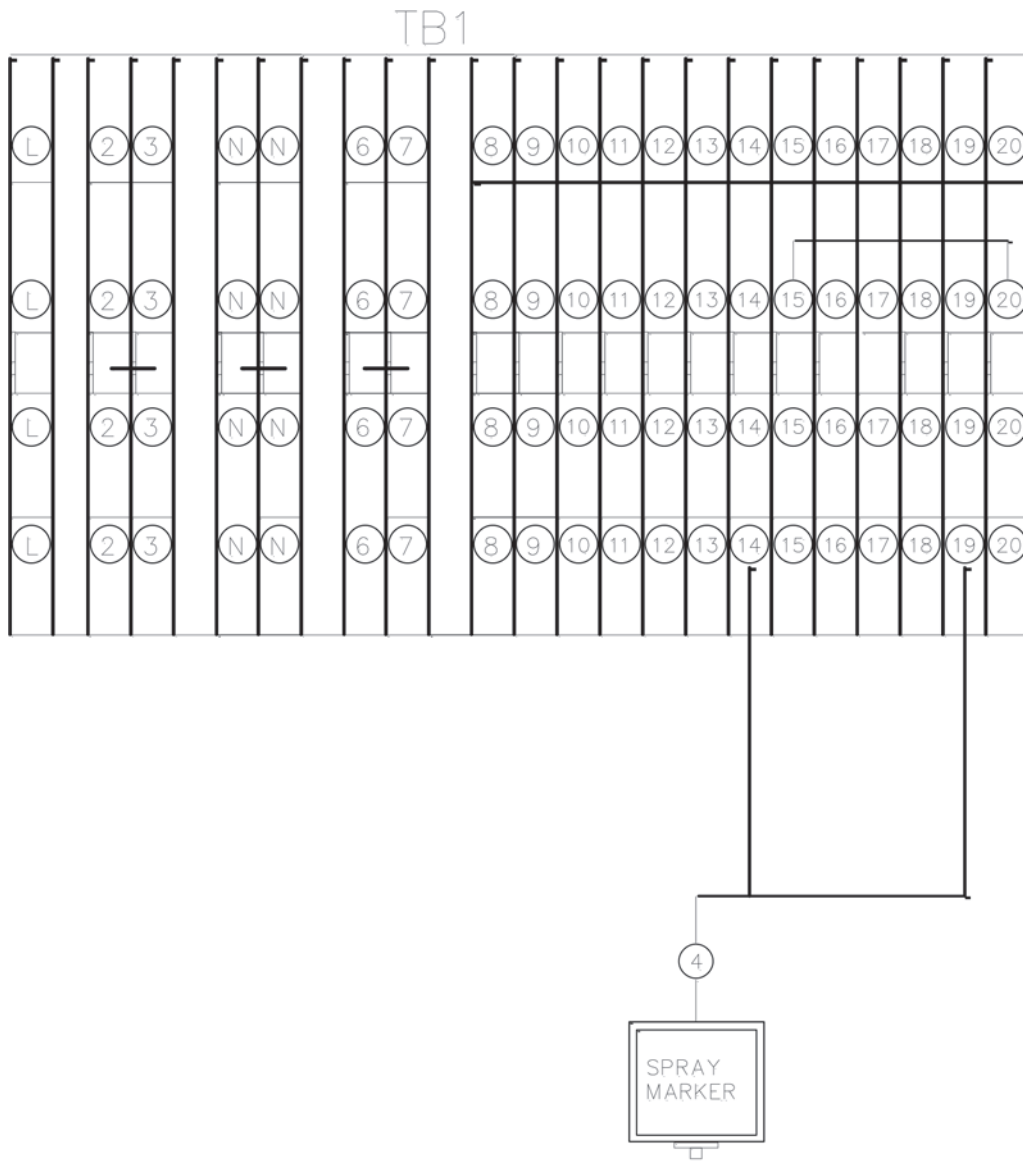

FIGURE A9
Dual Clip Detector Connection



SPRAY MARKER CONNECTION

COLOR	SCREW TERM
BLACK	14
WHITE	19

FIGURE A10
24VDC Spray Marker Connection

24VDC Spray Marker

Black Wire - Terminal 14

White Wire - Terminal 19

(You should see a factory installed jumper wire between terminals 15 and 20 on TB1.
Terminal 19 should be factory connected to Input/Output Terminal 19 on the main board.
Terminal 20 should be factory connected to Input/Output Terminal 17 on the main board)

TB1

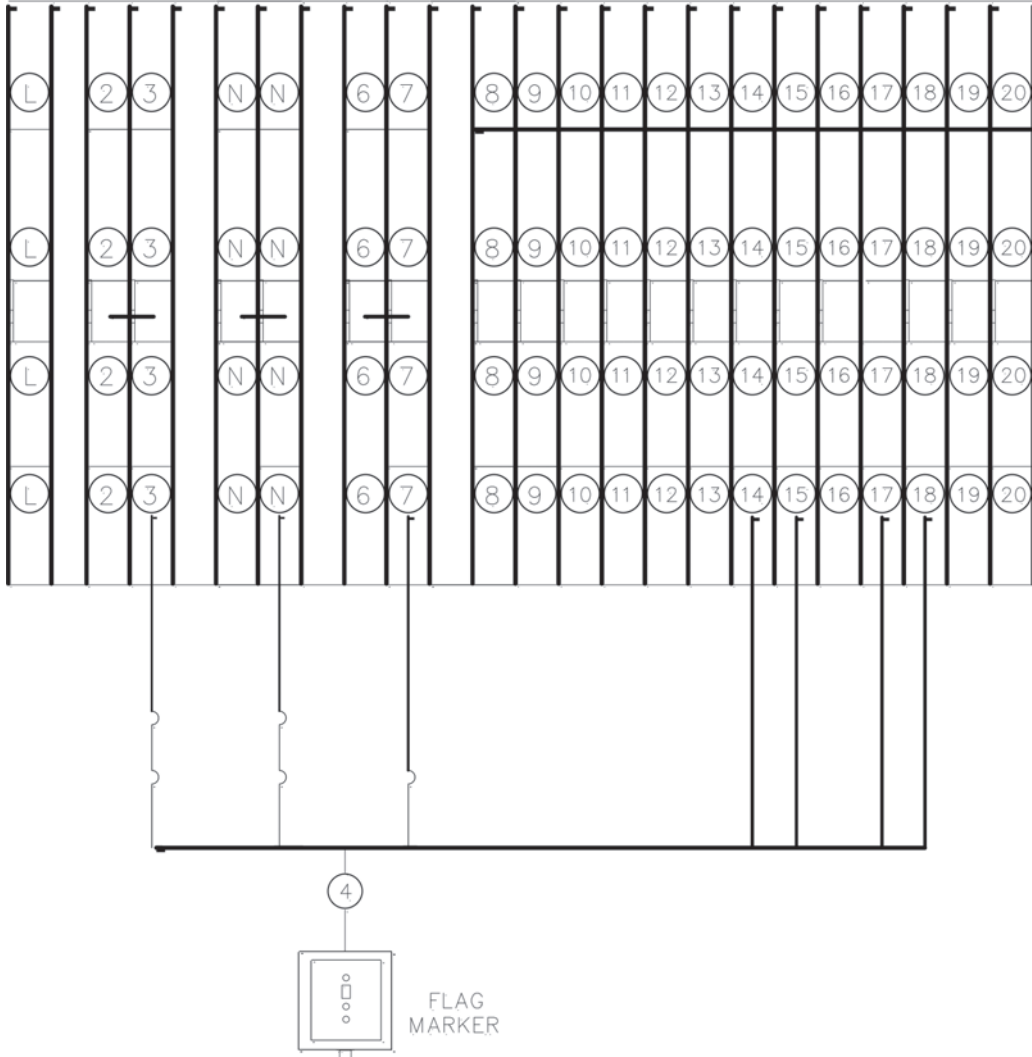

NOTE: DISCONNECT FLAG DROP MARKER CABLE CONNECTIONS AT THE MAINS AND TIMED OUT CONNECTORS PRIOR TO PERFORMING ANY WORK INSIDE FLAG DROP MARKER ENCLOSURE.

FLAG DROP MARKER CONNECTION

COLOR	SCREW TYPE
BLACK	3
WHITE	N (5)
GREEN	7
BLUE	14
RED/BLK	15
ORANGE	17
RED	18

FIGURE A11
Flag Drop Marker Connection

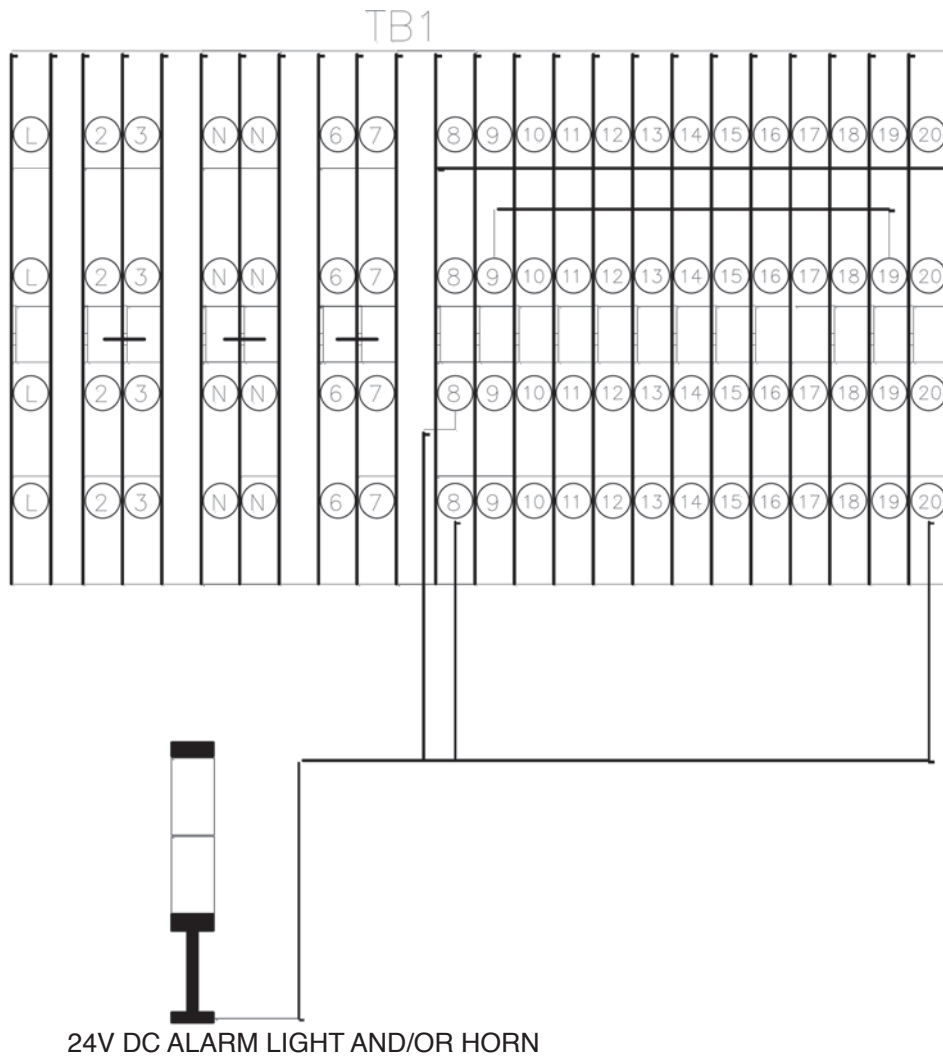

24V DC ALARM LIGHT AND/OR HORN

ALARM HORN & BEACON CONNECTION

COLOR	SCREW TYPE	SST TERM ST6
BLACK	20	17
WHITE	8	
BROWN	8	
BLUE	9 & 19	19

ALARM LIGHT AND/OR HORN WILL BE PRE-WIRED FOR PANEL MOUNTED LIGHTS/HORNS. ERIEZ DOES NOT SUPPLY CABLE FOR REMOTE MOUNTING AS STANDARD 18ga. 2 CONDUCTOR CABLE SHOULD BE USED.

FOLLOW INSTRUCTIONS WITH LIGHT/HORN FOR WIRING.

FIGURE A12
24VDC Panel Mounted Alarm Light and/or Horn Connection

Alarm Horn and/or Light

White Wire - Terminal 20

Black Wire - Terminal 8

(There should be a factory installed jumper wire between terminals 9 and 19 on TB1)



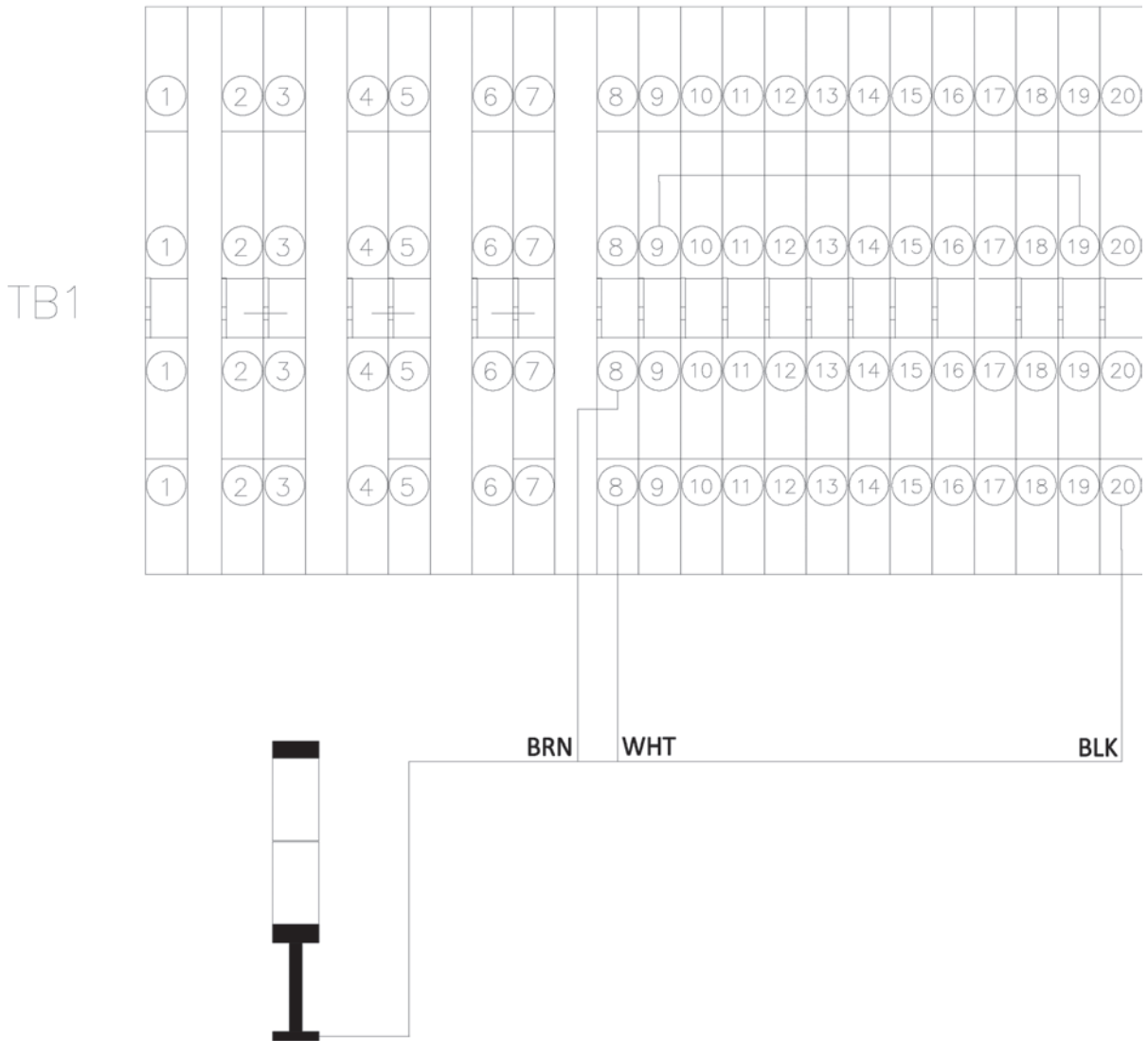

24V DC ALARM LIGHT AND/OR HORN

ALARM HORN & BEACON CONNECTION

COLOR	SCREW TYPE
BLACK	20
WHITE	8
BROWN	8
BLUE	9 & 19

ERIEZ DOES NOT SUPPLY CABLE FOR REMOTE MOUNTED AS STANDARD 18ga. 2 CONDUCTOR CABLE SHOULD BE USED, MAX LENGTH 250ft (76m). FOLLOW INSTRUCTIONS WITH LIGHT/HORN FOR WIRING.

FIGURE A13
24VDC Pole Mounted Alarm Light and/or Horn Connection



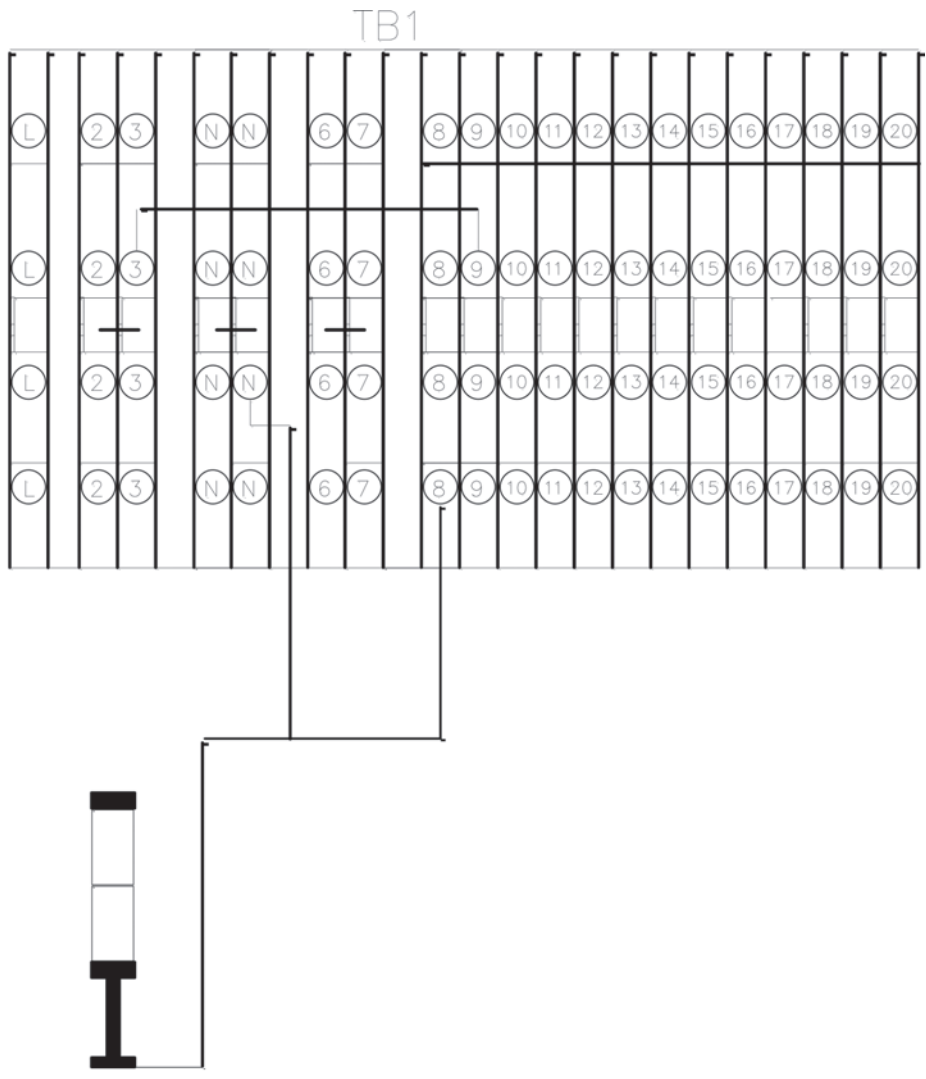

ALARM LIGHT AND/OR HORN

ALARM HORN & BEACON CONNECTION

COLOR	SCREW TYPE
BLACK	8
WHITE	5

ALARM LIGHT AND/OR HORN WILL BE PRE-WIRED FOR PANEL MOUNTED LIGHTS/HORNS. ERIEZ DOES NOT SUPPLY CABLE FOR REMOTE MOUNTING AS STANDARD 18ga. 2 CONDUCTOR CABLE SHOULD BE USED.

FOLLOW INSTRUCTIONS WITH LIGHT/HORN FOR WIRING.

FIGURE A14
115 or 240VAC Remote Alarm Light and/or Horn Connection

115 or 220VAC Alarm Horn and/or Light

White Wire - Terminal 8

Black Wire - Terminal 5

(There should be a factory installed jumper wire between terminals 3 and 9 on TB1)

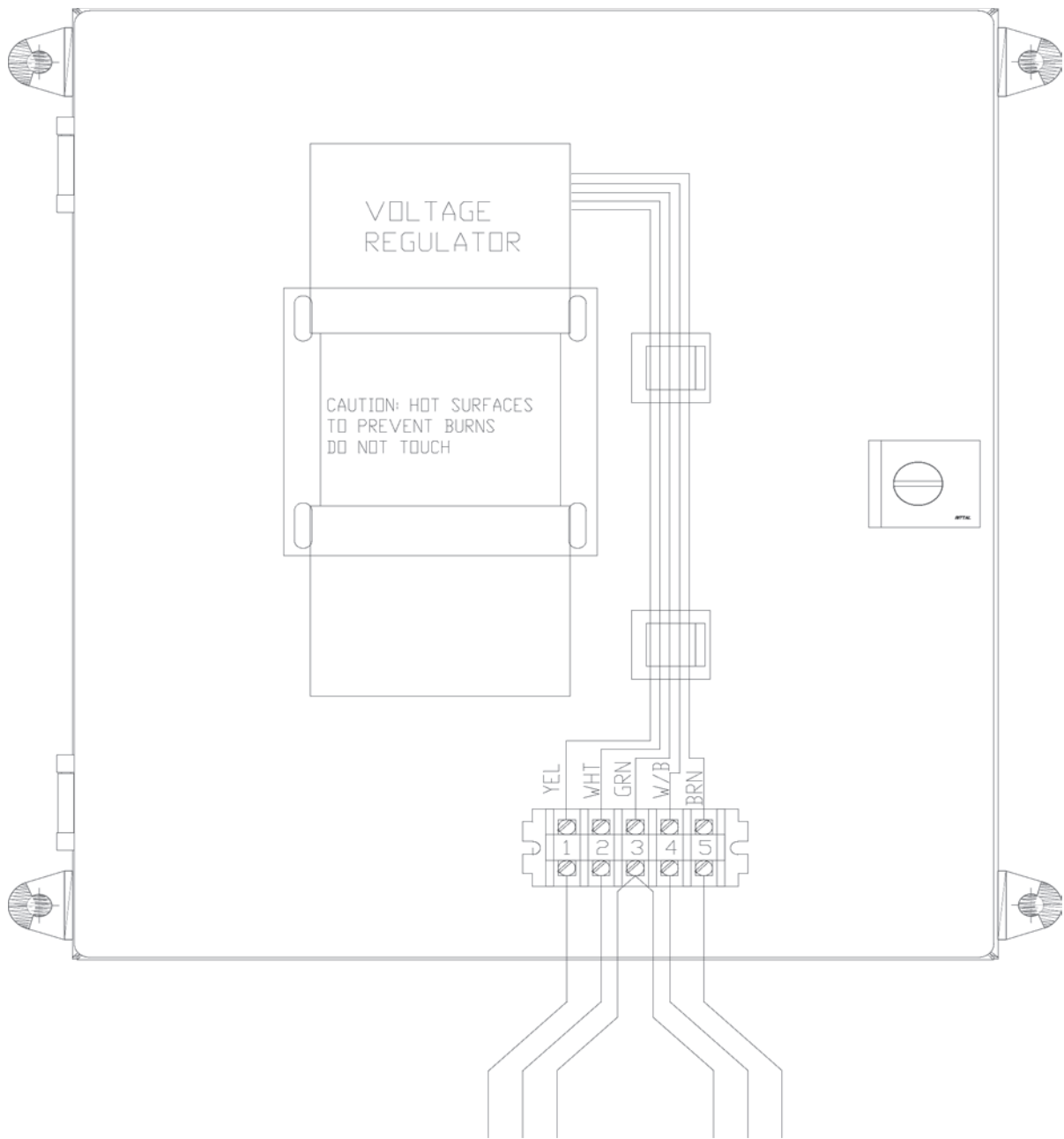

FIGURE A15
Voltage Regulator Connection

Voltage Regulator

- Voltage Regulator Terminal 1 - Input Power 115VAC or 220VAC
- Voltage Regulator Terminal 2 - Input Neutral or 220VAC
- Voltage Regulator Terminal 3 - Ground (Earth) (Input and Output)
- Voltage Regulator Terminal 4 - Output Neutral or 220VAC
- Voltage Regulator Terminal 5 - Output 115VAC or 220VAC

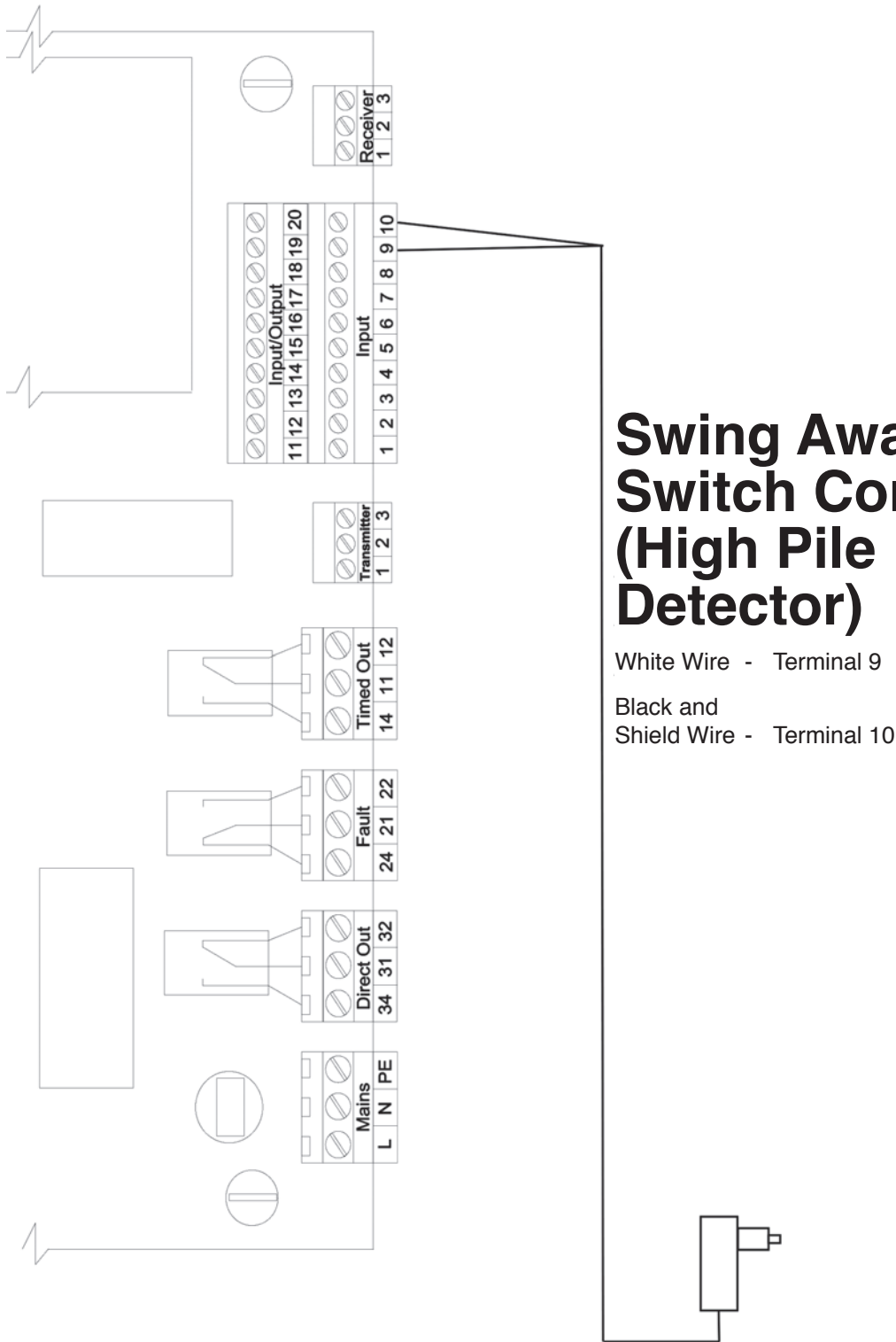

FIGURE A16
Swing Away Switch Connection

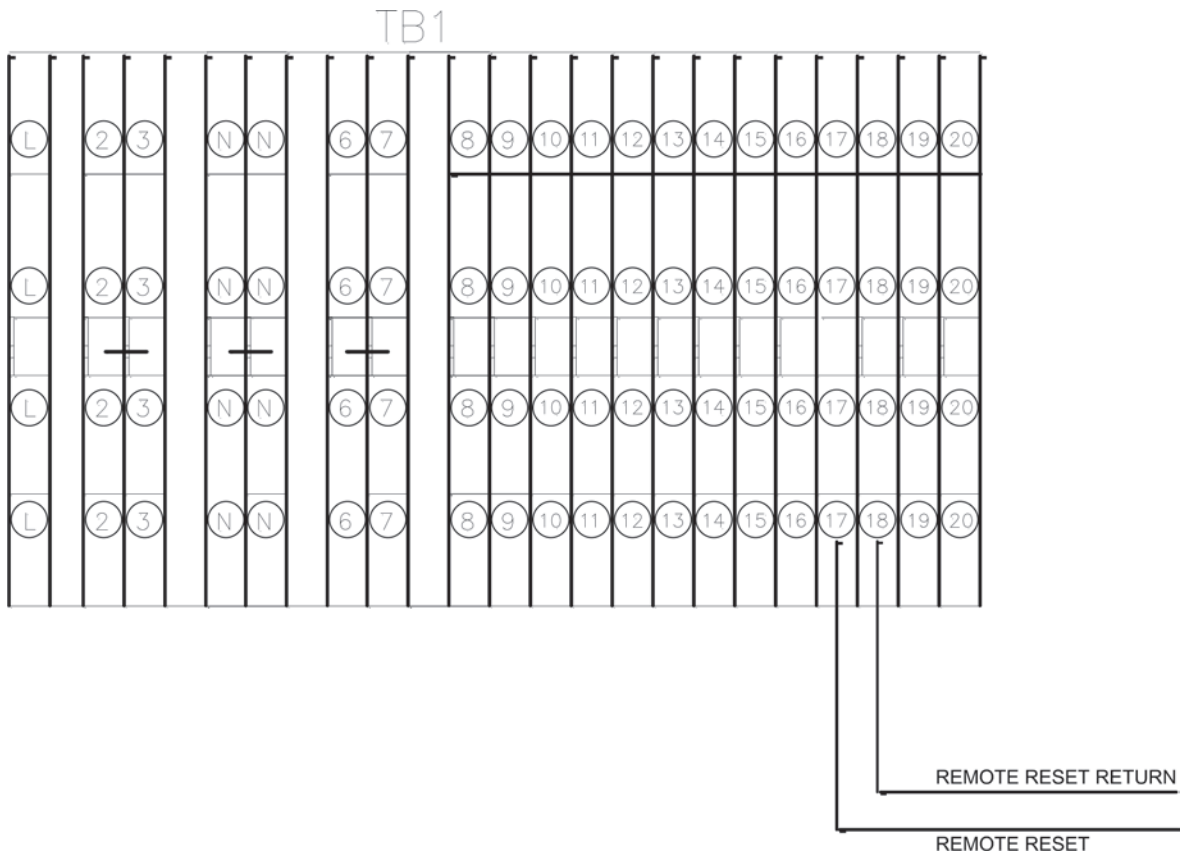

FIGURE A17
Remote Reset Connection

Remote Reset Connection

Red Wire - Terminal 17

Orange Wire - Terminal 18

The remote reset can be used to remotely reset the metal detector after metal has been detected.

Do not apply voltage to these terminals! Dry contact only!



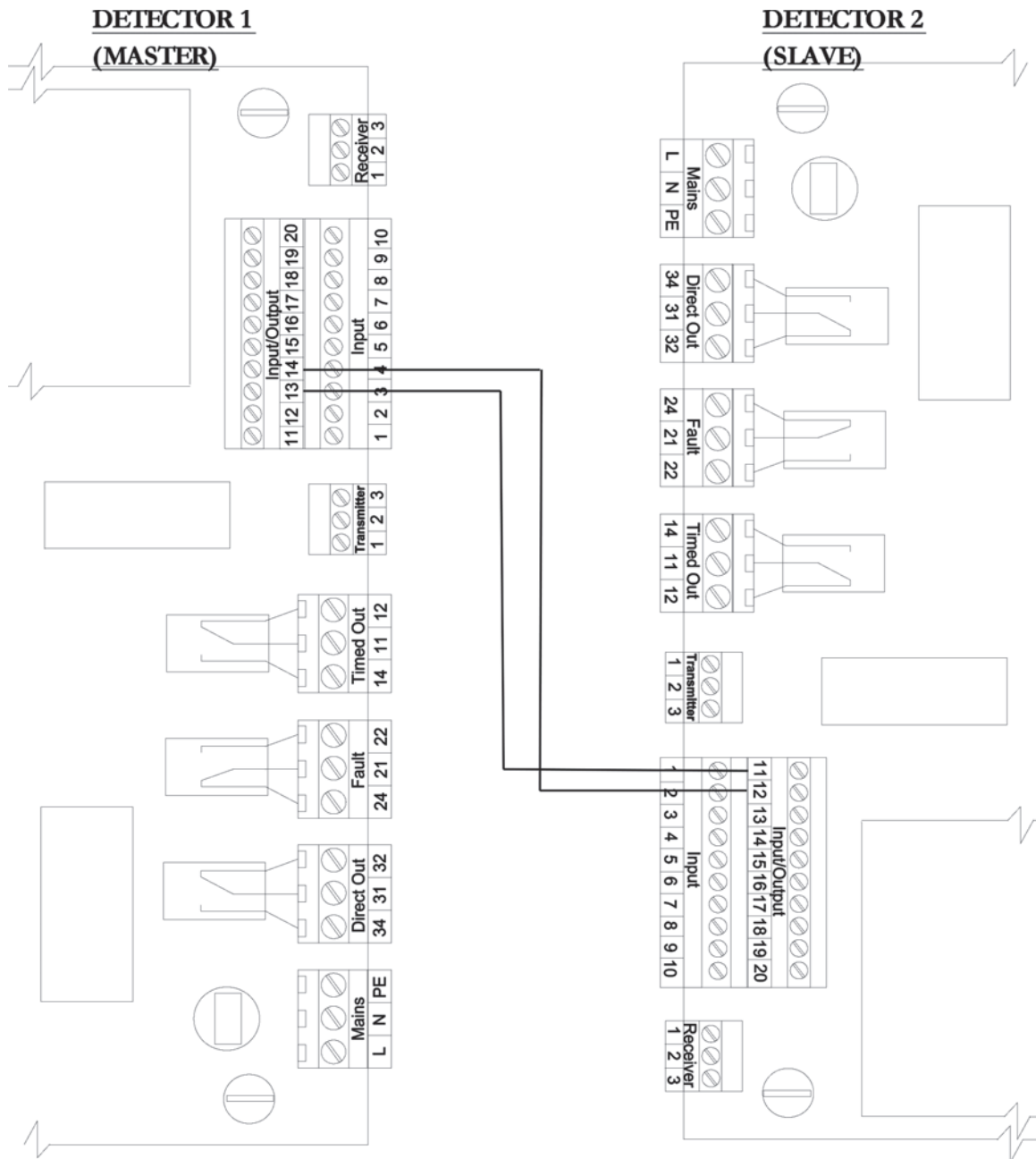

FIGURE A18
Detector Synchronization

Synchronizing 2 Detectors

When installed within 100' with direct line of sight

Detector 1 (Master) Terminal 13 Sync Out + - Connects to Terminal 11 Sync In+ on Detector 2 (Slave)

Detector 1 (Master) Terminal 14 Sync Out - - Connects to Terminal 12 Sync In- on Detector 2 (Slave)

If more than 2 detectors need to be synchronized, they can be daisy-chained, so Detector 2 would be master for Detector 3 and so on

Wire Descriptions and Sizes: See page 20

APPENDIX B

Service, Parts, Repairs

This section of the manual provides information about service and repair of your metal detector. **When you call for service you MUST have the serial number from the electronics, or the Eriez Order number available.** Please direct all service inquiries directly to Eriez at +1 814-835-6000

Eriez can provide on-site service for your metal detector to assist with calibration & start-up, customer training, or troubleshooting. Contact Eriez (+1 814-835-6000) to schedule on-site service. **When you call for parts you MUST have the serial number from the electronics, or the Eriez Order number available to ensure you receive the correct parts.** A general drawing with parts listed is shown on the next page. This is to assist you in determining which parts need replacement.

Eriez also offers repair services for the electronics at our facility in Erie, Pennsylvania. When sending ANY materials to Eriez, you must have a Returned Goods Authorization (RGA) number issued by Eriez. For your convenience we have provided a form for providing the necessary information to obtain an RGA number. Simply fill out the form and fax it to Eriez, or call Eriez with all the information required and you will be issued an RGA number.

DO NOT SEND MATERIALS TO ERIEZ WITHOUT AN RGA NUMBER!

This is essential for tracking the goods you are returning to us. Eriez is not responsible for goods shipped without an RGA number.



Replacing Electronic Boards

The Eriez 1230 control unit consists of 3 electronic boards, **Evaluation electronics**, the **Signal analyzer board** and the **Display board** (see next page).

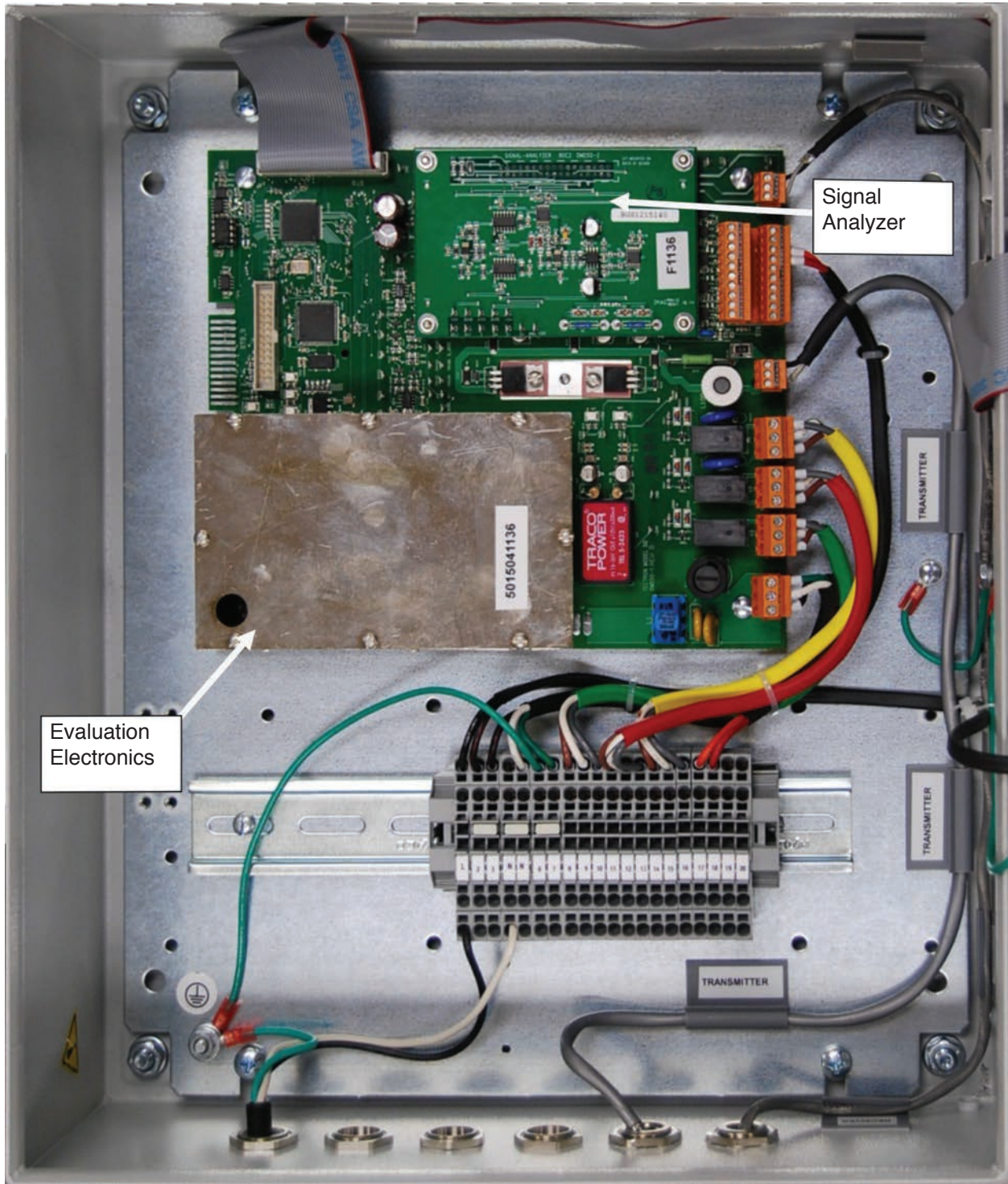

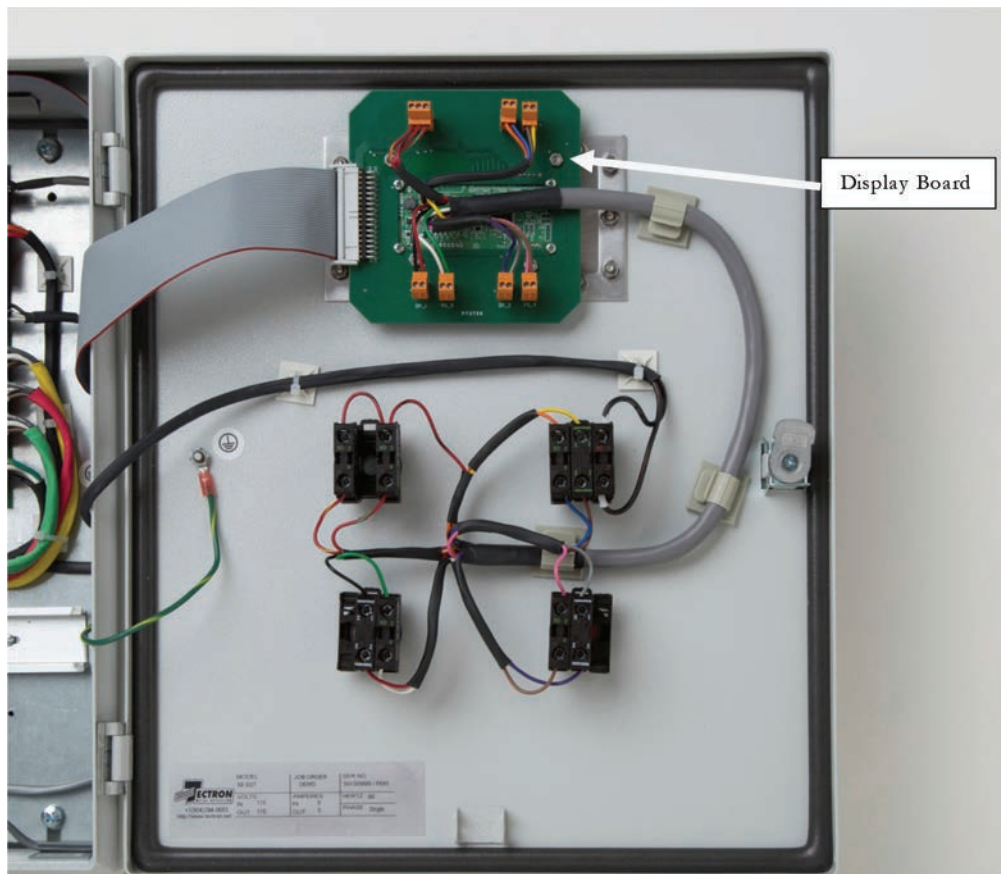

i The “Eriez 1230” Evaluation Electronics are equipped with a memory module which contains all the equipment settings and product data. If this memory board is transferred to the new Evaluation Electronics board the original settings will be transferred to the new board.

Replacing the data memory:

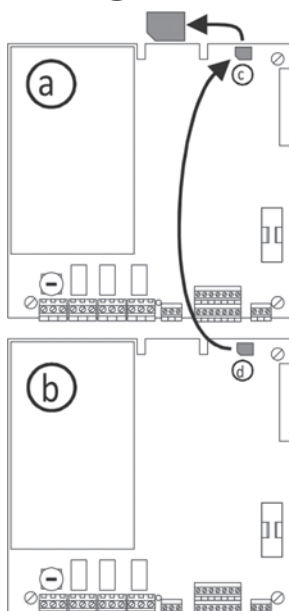

- a: New Evaluation Electronics board
- b: Old Evaluation Electronics board
- c,d: Device and program memory

Procedure:

1. Remove data memory c) from the new (already installed) Evaluation Electronics board a) and reserve for a spare.
2. Remove data memory d) from the old Evaluation Electronics board b) and carefully plug it into the new Evaluation Electronics board a).
3. Ensure that the clipped corner of the memory device points to the left.
4. Switch on power supply. The new board will run with the settings from the “old” Evaluation Electronics module.

Replacing the Main Electronics Module

Before starting ensure incoming power is disconnected to metal detector and outputs.

The signal analyzer should be kept with the detector because it is matched to the antennas

- A. Remove 4 nuts holding the signal analyzer (5) to the defective Evaluation Electronics module (3) with 5.5mm or 7/32" socket wrench or pliers. If there are washers installed, remove these as well.
- B. Remove the signal analyzer from the defective Evaluation Electronics module by pulling it straight out.
- C. Install signal analyzer on new Evaluation Electronics module by carefully inserting pins into socket connector. Use care to not bend the pins when placing it into the new Evaluation Electronics module
- D. Secure the signal analyzer to the new Evaluation Electronics module using the 4 nuts (and washers if applicable...newer versions do not require washers)
- E. Remove the 8 connectors for the Mains, Direct Out, Fault, Timed Out, Transmitter, "Input/Output," "Input," and Receiver.
- F. Remove the nut holding the ground (earth) wire to the back plate, and remove the wire from the back plate
- G. Disconnect the ribbon cable from the Evaluation Electronics module by lifting the plug straight up from the socket
- H. The Evaluation Electronics module is secured to the enclosure (4) by four screws. Remove the screws holding back plate to the enclosure with a Phillips head screw driver. (Note: You may have 7mm barrel nuts instead of the Phillips head screws)
- I. Remove back plate and Evaluation Electronics module from enclosure.
- J. Place new Evaluation Electronics module into the enclosure and secure it using the four Phillips head screws to hold the back plate to the enclosure
- K. Replace the 8 connectors for the Mains, Direct Out, Fault, Timed Out, Transmitter, "Input/Output," "Input," and Receiver.
- L. Secure the ground (earth) wire to the back plate using the nut the nut holding the ground (earth) wire to the back plate.
- M. Reconnect the ribbon cable to the socket on the Evaluation Electronics module being careful not to bend any pins

Replacing the Display Board

Before starting ensure incoming power is disconnected to metal detector and outputs.

- A. Disconnect ribbon cable from connector on display board
- B. Remove 4-1/4" nuts securing display board to faceplate
- C. Remove display board
- D. Install new display board in reverse order, B – A



Spare Parts, Servicing

Please state type of equipment and serial number when contacting us.

Spare Parts Drawing

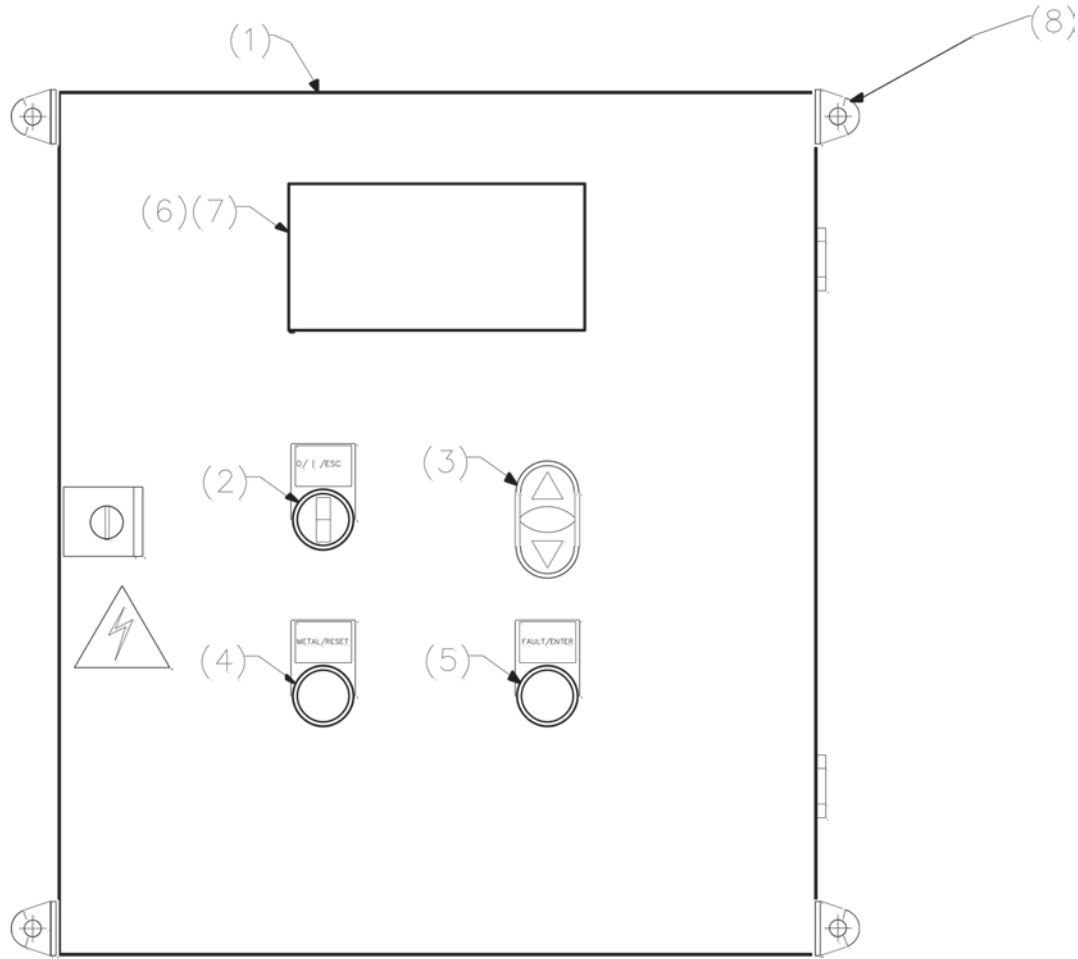

Spare Parts List

Item No.	Part	Remarks Drawing No.
1	Enclosure	Mild Steel (other options avail.)
2	On/Off/Esc - 3 way switch w/ legend	
3	Up/Down Arrow Buttons	
4	Metal Light / Reset Button (Yellow) w/ legend	
5	Fault / Enter Button (Red) w/ legend	
6	Display Electronics Module (VFD)	Not Shown (Inside enclosure)
7	Faceplate overlay, Display rev B	
8	Bracket, Wall mount, Zinc plated steel	Mild Steel (other options avail.)
9	Main Electronics Module incl. backplate, Terminal strip, DIN rail and signal analyzer	Not shown



Frame Assembly

No. Name

- 1 Crossbar
- 2 Left upright up to 72" length
- 2 Left upright over 72" length
- 3 Right upright up to 72" length
- 3 Right upright over 72" length
- 4 Mounting feet carbon steel
- 5 Receiver Bracket Left
- 5 Receiver Bracket Right
- 6 Transmitter Bracket Left
- 6 Transmitter Bracket Right
- 7 Receiver Antenna (xx = coil length)
- 8 Transmitter Antenna (xx = coil length 1380Hz)
- 9 Roughing Guard (optional)
- 10 Swing-Away Switch (optional)

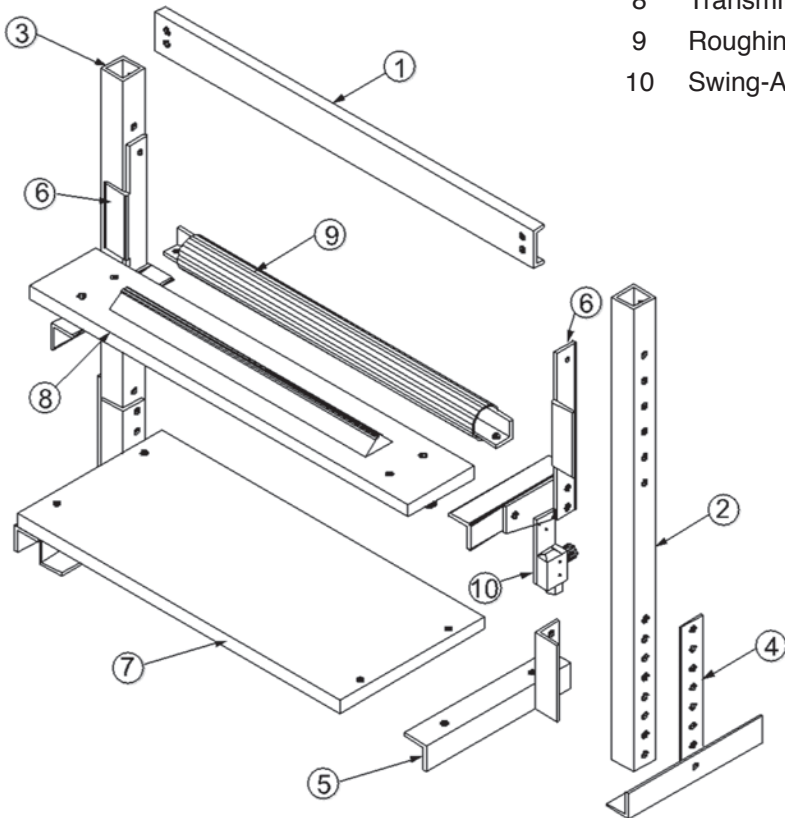

Eriez and Eriez Magnetics are registered trademarks of Eriez Manufacturing Co, Erie, PA

©2016 Eriez Magnetics All Rights Reserved



World Authority in Separation Technologies

Headquarters: 2200 Asbury Road, Erie, PA 16506-1402 U.S.A.

Telephone: 814-835-6000 • 800-345-4946 • Fax: 814-838-4960 • International Fax: 814-833-3348

Web Site: <http://www.eriez.com> e-mail: eriez@eriez.com

Manufacturing Facilities: AUSTRALIA • BRAZIL • CANADA • CHINA • INDIA • JAPAN • MEXICO • SOUTH AFRICA • UNITED KINGDOM • UNITED STATES

