

Installation, Operation and Maintenance Instructions



**PERMANENT
MAGNETIC
DRY DRUM
SEPARATORS
TYPE A, CC, RE,
MODEL H, HF AND HFP**

ERIEZ MAGNETICS HEADQUARTERS: 2200 ASBURY ROAD, P.O. BOX 10608, ERIE, PA 16514-0608 U.S.A.
WORLD AUTHORITY IN ADVANCED TECHNOLOGY FOR MAGNETIC, VIBRATORY and METAL DETECTION APPLICATIONS

Introduction

This manual describes Eriez' Permanent Magnetic Dry Drum Separators. Erium®-powered Dry Drum Separators provide superior magnetic protection and higher levels of purity in food, grain, chemical and ore treatment applications.

A careful reading of these Installation, Operation and Maintenance Instructions will assure the most efficient and dependable performance of this equipment.

Please include the model and serial number found on the nameplate with any correspondence concerning your Drum Separator.

If there are any questions or comments about the manual, please call the factory at 814/835-6000 for Dry Drum Separator assistance.



CAUTION - STRONG MAGNET

This equipment includes one or more extremely powerful magnetic circuits. The magnetic field may be much stronger than the Earth's background field at a distance several times the largest dimension of the equipment.

- **If you use a heart pacemaker or similar device you must never approach the equipment because your device may malfunction in the magnetic field, with consequences up to and including death.**
- **To avoid serious pinch-type injuries caused by objects attracted to the magnet, keep all steel and iron objects well away from the equipment. Do not allow hands, fingers, and other body parts to be caught between the equipment and nearby steel or iron objects.**
- **Keep credit cards, computer disks, and other magnetic storage devices away from the equipment because magnetically stored information may be corrupted by the magnetic field.**
- **Keep electronic devices, such as computers or monitors, away from the equipment because exposure to the magnetic field may result in malfunction or permanent damage to such devices.**

Contact Eriez if you have a question regarding these precautions.



CAUTION

Safety labels must be affixed to this product. Should the safety label(s) be damaged, dislodged or removed, contact Eriez for replacement.

Table of Contents

ERIEZ PERMANENT MAGNETIC DRY DRUM SEPARATORS

GENERAL DESCRIPTION	4
INSTALLATION	4
Style 1	4
Style 2	6
MAINTENANCE	6
Bearing Replacement	6
Shell Replacement Drum Only	7
Shell Replacement Drum in Housing	8
APPENDIX	10
Installation Type RE (15" Diameter Drum Only)	10
FACTORS THAT AFFECT MAGNET PERFORMANCE	11



General Description

Dry drum separators are primarily designed for removal of tramp iron from heavy flows of bulk materials. They are also used in the purification of granular free-flowing materials as well as for up-grading metal turnings and borings.

The drum separator consists of a stationary magnetic element mounted on a shaft. A cylindrical stainless steel shell encloses the magnet assembly and is secured to the drum head. The drum heads and shell assembly rotate on a bearing assembly mounted to the shaft. Model H and HFP Separators are furnished complete with housings of welded steel construction. Totally enclosed motor with V-Belt drive and guard is furnished.

The Type CC Drum is furnished with one stainless steel wiper strip welded to the drum shell. It is furnished separately or mounted in a Model H, HF or HFP Housing.

Drum flanges are of aluminum alloy construction except on heavy duty units which have cast manganese bronze flanges. All bearings are of the sealed type. Seals prevent entry of harmful dust or abrasives into the drum interior.

The drum is furnished with a split shaft. The magnetic element is mounted to half of the shaft which is clamped in place. The shaft on the opposite side is fastened to the drum head and is keyed so it can be driven by a V-Belt sheave or sprocket.

Standard magnet circuits are suitable for temperatures below 150 degrees Fahrenheit (60°C). Special circuits are required for higher temperatures depending upon application criteria. Please review the Eriez order acknowledgment or contact your local representative if you have questions about the circuit provided and its temperature limitations

Installation

The magnetic element is of the permanent magnetic type and requires no external power source. Installation of the separator will vary depending upon the type of unit purchased. There are two basic styles available.

STYLE 1. Type A, CC, and *RE [12" (305mm) diameter only]

1. Drum should be installed on a support frame using a pillow block bearing on the shaft extension which is keyed and a shaft clamp block on the opposite shaft extension. Before clamping the shaft in place, the magnetic element should be correctly positioned as illustrated in Figure 1.

It is important that the separator be operated at the correct speed. Recommended motor horsepower and operating speed are listed in Table 1.

*FOR RE 15" DIAMETER DRUM SPECIFICATIONS, SEE APPENDIX.

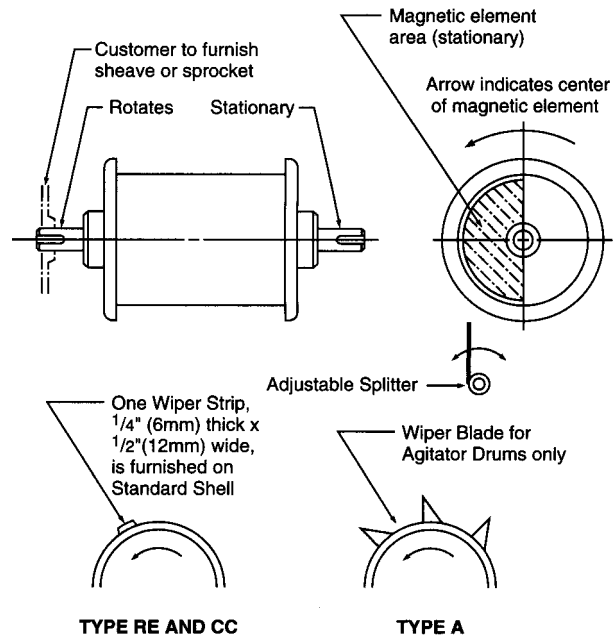

FIGURE 1

Installation (cont.)

2. A tramp iron divider is required and should be positioned below the drum as illustrated in Figure 1. The splitter should have a knife edge and be fabricated of a nonmagnetic material such as aluminum or stainless steel. It should be adjustable in both position and length. Correct adjustment will be determined when the unit is operating.
3. Provisions should be made to provide a uniform controlled feed to the separator. This is best accomplished by use of an Eriez Hi-Vi Electromagnetic Vibratory Feeder. An alternate method would be a hopper and chute arrangement. An adjustable feed gate is recommended to control any surge of material. Since the drum cylinder is relatively thin with a close tolerance between itself and the magnetic element, care

must be taken to prevent heavy pieces of material or tramp iron from impacting on and denting or damaging the shell. For best results feed should be laid onto the drum surface.

4. With the drum operating and material running over the drum surface, the tramp iron divider is adjusted. When positioned behind the natural trajectory of material discharged from the drum, maximum clearance is obtained for removal of large heavy ferrous objects. With cohesive or damp materials, the splitter should be moved back away from the natural trajectory to minimize nonmagnetic carry over or loss. Some product loss may be necessary in order to produce efficient magnetic removal. Correct positioning of the splitter can keep product loss to a minimum.

TABLE 1. RECOMMENDED DRIVE DATA

		WIDTH											
		12" (305mm)	14" (356mm)	16" (406mm)	18" (457mm)	20" (508mm)	24" (610mm)	30" (762mm)	36" (914mm)	42" (1067mm)	48" (1219mm)	54" (1372mm)	60" (1524mm)
D I A M E T E R	12"(305mm) 45 RPM	1/3	1/3	1/3	1/3	1/3	1/3	1/3	1/2	1/2	X	X	X
	15"(381mm) 40 R PM	1/3	1/3	1/3	1/3	1/3	1/3	1/2	1/2	3/4	3/4	X	X
	18"(457mm) 35 RPM	1/3	1/3	1/3	1/2	1/2	1/2	3/4	3/4	3/4	3/4	X	X
	24"(610mm) 30 RPM	X	X	X	3/4	3/4	3/4	1	1	1 1/2	1 1/2	1 1/2	1 1/2
	15"(381mm) RESP 42 1/2 RPM	3/4	3/4	3/4	3/4	3/4	3/4	1	1 1/2	3	3	3	3

Installation (cont.)

STYLE 2. Model H, HF and HFP (Figures 2 and 3)

1. Model H, HF and HFP Drum Separators are easily installed into a system by connecting material ducts to flanges provided on the separator. A chute or tramp iron box should be provided for tramp iron collection.
2. An adjustable feed gate is provided on the feed hopper to regulate feed to the separator.

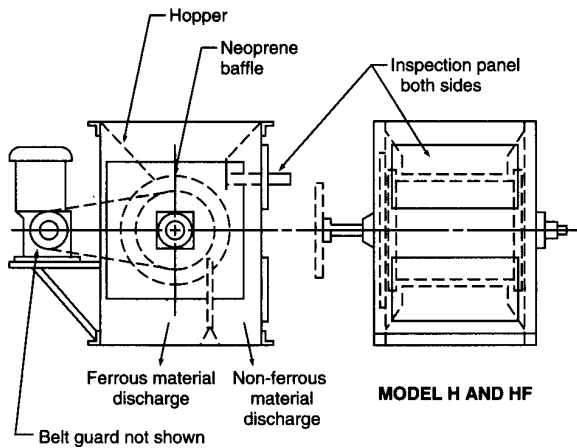

FIGURE 2

3. Before operating be sure Instructions attached to the motor are reviewed.
4. Tramp iron divider may have to be adjusted for optimum performance. It is adjusted in the same manner as suggested for the drum only as covered in paragraph 4, page 4.

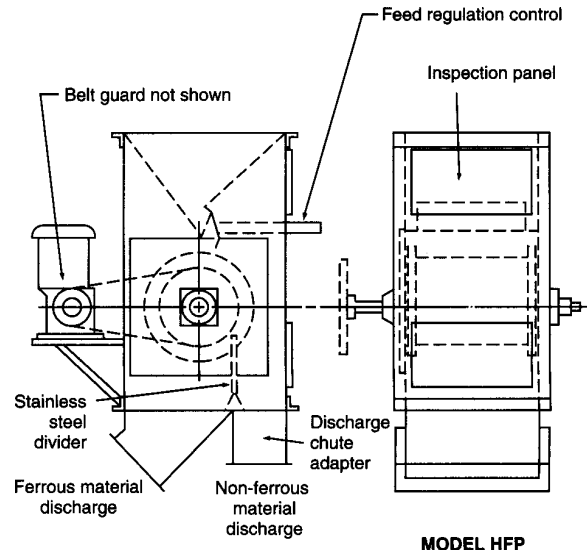

FIGURE 3

Maintenance

Bearing Replacement

Eriez Permanent Magnetic Drum Separators ordinarily require no maintenance. The standard units have ball bearings which are sealed and permanently lubricated. Optional bearing designs such as greasable ball bearings and oilite should be lubricated on a schedule consistent with other equipment in use with your product and environment. An NGLI No. 2 lithium base grease is recommended for use with ball bearings and SEA #30 oil with oilite. In the event that bearings require replacement, the following procedure should be followed:

1. Set drum up in support as shown in Figure 4. The end with worn bearing is up.

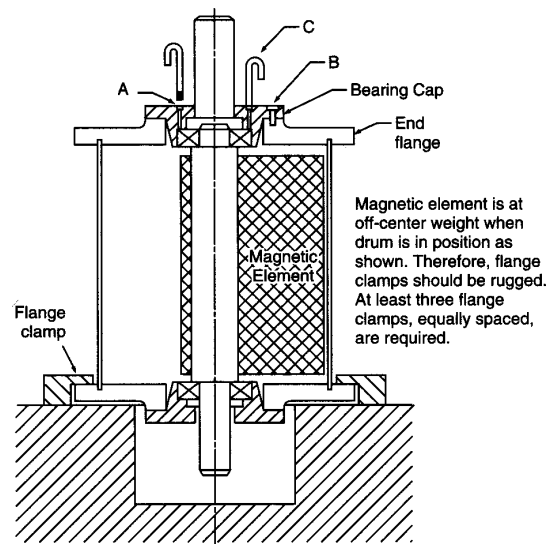

FIGURE 4

Maintenance (cont.)

2. Remove two 3/8-16 socket head set bolts marked "A" and six socket head cap bolts marked "B."
3. Screw in two hooks or threaded rods marked "C" (3/8-16 THD).
4. Remove bearing cap from end flange as shown in Figure 5. Use caution so as to prevent foreign matter from entering the opening.
5. Tap out bearing using 3/16 (4mm) rod as shown in Figure 6. Alternate between the two holes.
6. Bearing option - Oilite or sleeve Bearing Design: use appropriate puller to remove bearing.
7. Press new bearing in bearing cap.
8. Replace bearing cap and end flange. Tapered side of bearing cap will facilitate reentry.

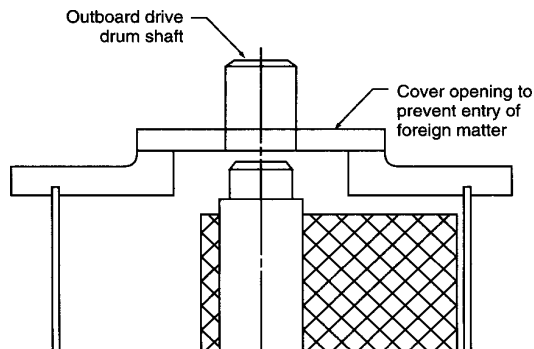

FIGURE 5

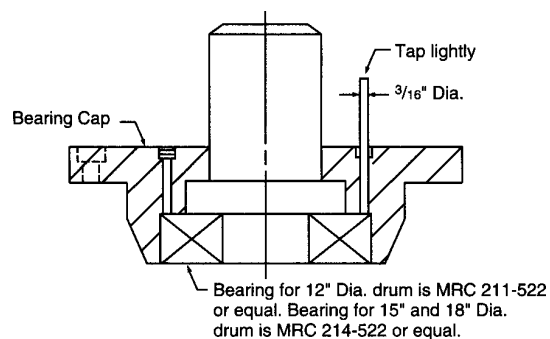

FIGURE 6

9. Replace end bolts "A" and cap bolts "B."
10. Turn drum over and repeat procedure for other end if necessary.

Shell Replacement Drum Only

Should the drum shell become dented or excessively worn, the following procedure should be followed for shell replacement: (if separator was furnished with a housing see next section).

1. Remove drum from installation and remove caulking from chamfered grooves and counter-sunk holes as shown in Figure 7.
2. Set drum up in support as shown in Figure 8. Drive end to be down. Remove nuts from studs in the lower flange only.

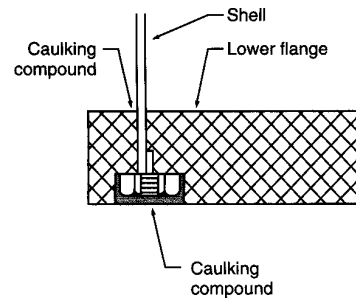

FIGURE 7

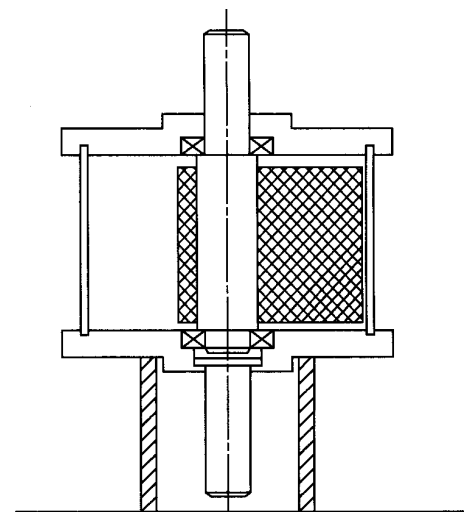

FIGURE 8

Maintenance (cont.)

3. Tap underside of upper flange lightly until shell rim separates from lower flange, see Figure 9. Lift shell off (CAUTION: STRONG MAGNET). At this point the magnetic element will be exposed. It must not be tampered with in any way. Do not allow steel tools or other ferrous pieces to touch the magnetic element.
4. Remove nuts from studs in the upper flange and remove shell as shown in Figure 10.

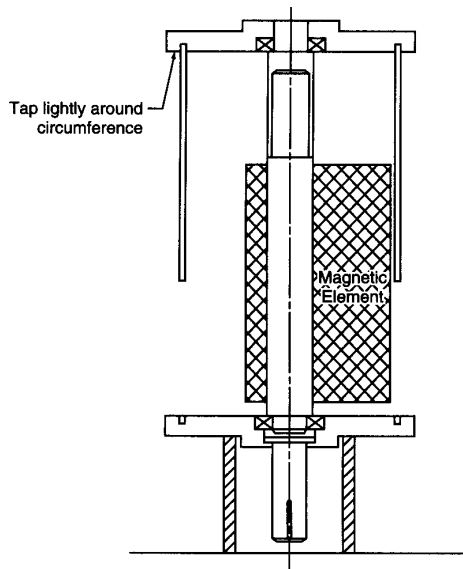

FIGURE 9

If drum shell has wiper vanes the new shell must be installed so that flat surface is in the same direction as on the old assembly.

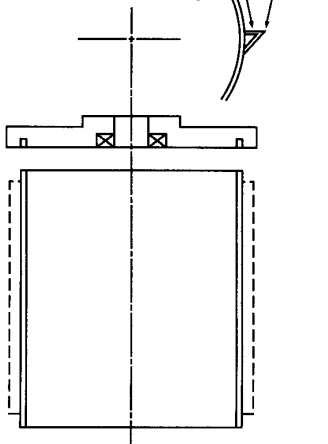

FIGURE 10

5. Install the new shell by reversing the entire procedure. If there is interference when the new shell is slipped over the magnetic element, mark interference spots on the inside of the shell and grind. Wipe off (using a cloth) any fine iron which may have accumulated on the element. Blotting the magnet with the sticky side of masking tape will also help remove fine iron.
6. After determining that the new shell will turn freely, seal grooves and countersunk holes in end flanges with caulking compound.

Shell Replacement Drum in Housing

If the drum is mounted in a housing, it is first necessary to remove the drum from the housing before proceeding as above. The following procedure should be used to remove the drum from the housing. For Type H Housing, see Figure 11.

1. Remove flange collar clamp marked "C."
2. Support drum by shaft ends.
3. Remove nuts marked "D" and slide covers marked "E" off studs. Do not allow drum to drop when covers come off studs.

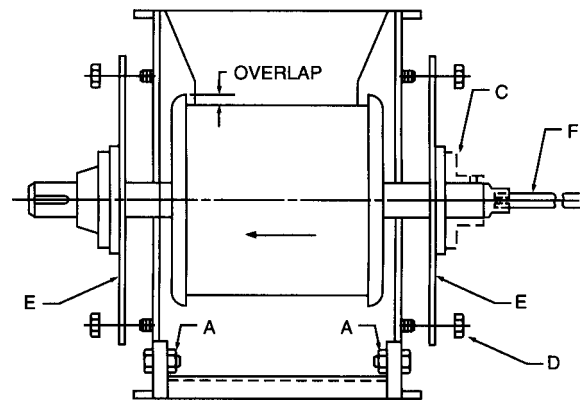

TYPE H HOUSING

FIGURE 11

Maintenance (cont.)

4. Lower drum just enough so overlap between drum flanges and hopper is disengaged.
5. Screw in rod marked "F" (see Figure 13). Support both ends of shaft inside cover, slide covers off shaft.
6. Pass drum through housing in direction of arrow. To remove drum from Type HF Housing (see Figure 12):
 1. Support drive end of shaft.
 2. Remove nuts "D" and slide cover "E" off studs.
 3. Screw in rod "F" (see Figure 13).
 4. Pass drum through housing in direction of arrow.

⚠ Caution: Alteration or disassembly of the magnetic element would disturb a carefully engineered magnetic circuit which could only be restored by returning the unit to our factory for rebuilding and recharging.

For motor and reducer maintenance, refer to the manufacturers instructions packed with the shipment.

Repair, alteration, or disassembly of this magnetic equipment in the field without written authorization and instructions from Eriez Manufacturing Company nullifies responsibility and guarantee of the manufacturer. See important information on back of guarantee.

If additional information or advice is required, contact your nearest Eriez representative who is an expert on magnets and their application.

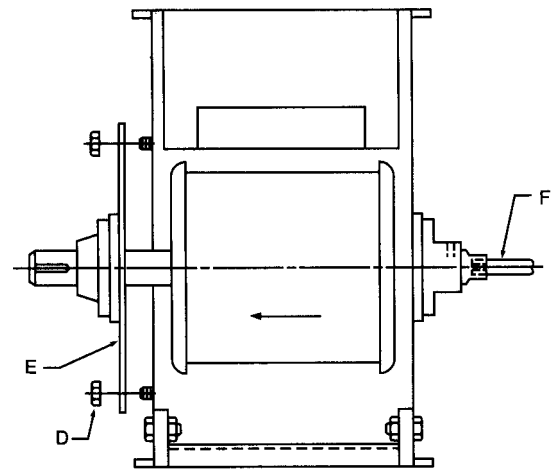

TYPE HF HOUSING

FIGURE 12

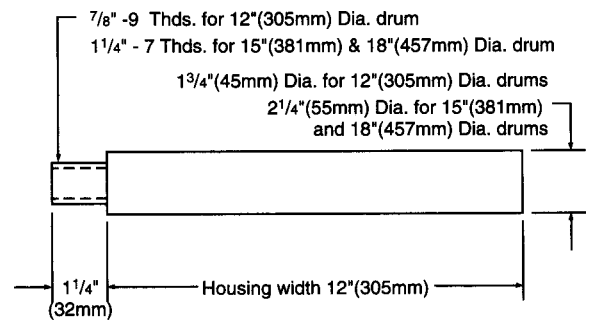

FIGURE 13

Appendix

Installation Type RE 15" Diameter Drum only

1. Drum should be installed on a support frame using a pillow block bearing on the shaft extension which is keyed and a shaft clamp block on the opposite shaft extension. Before clamping the shaft in place, the magnetic element should be correctly positioned as illustrated in Figure 14.

It is important that the separator be operated at the correct speed.

Recommended motor horsepower and operating speed are listed in Table 1.

2. A tramp iron divider is required and should be positioned below the drum as illustrated in Figure 14. The splitter should have a knife edge and be fabricated of a nonmagnetic material such as aluminum or stainless steel. It should be adjustable in both position and length. Correct adjustment will be determined when the unit is operating.

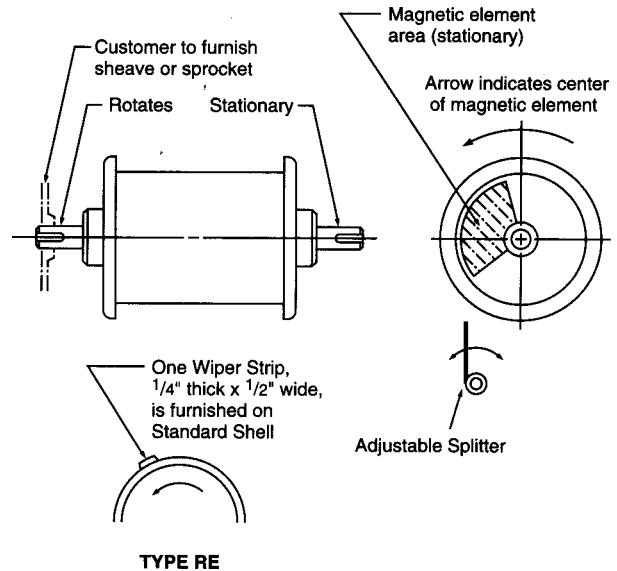

FIGURE 14

TABLE 2. RECOMMENDED DRIVE DATA

		WIDTH											
D I A M E T E R		12" (305mm)	14" (356mm)	16" (406mm)	18" (457mm)	20" (508mm)	24" (610mm)	30" (762mm)	36" (914mm)	42" (1067mm)	48" (1219mm)	54" (1372mm)	60" (1524mm)
	15" (381) 40 RPM		3/4	3/4	3/4	3/4	3/4	3/4	1	1 1/2	3	3	3

Factors that Affect Magnet Performance

1. High Temperature

Standard rare earth circuits should not be subjected to temperatures in excess of 150°F (65°C). Special circuits are available for higher temperatures.

2. Direct Current

Welding equipment should not be used on or in close proximity to Eriez Permanent magnet circuits. Demagnetization can result from this.

3. Moisture

The raw magnet material should not be exposed to liquids. This would normally only result from breaching the magnet enclosure.

4. Ferrous Material Inside Drum

Holes or cracks in the drum shell will allow ferrous material to enter and stick to the magnet shunting out the field.



World Authority in Advanced Technology for Magnetic, Vibratory and Metal Detection Applications

HEADQUARTERS: 2200 ASBURY ROAD, P.O. BOX 10608, ERIE, PA 16514-0608 U.S.A.

Telephone 814/835-6000 • 800/345-4946 • Fax 814/838-4960 • International Fax 814/833-3348

Web Site: <http://www.eriez.com>

e-mail: eriez@eriez.com

MANUFACTURING FACILITIES IN: AUSTRALIA • CANADA • CHINA • INDIA • JAPAN • MEXICO • SOUTH AFRICA • UNITED KINGDOM • UNITED STATES