

Installation, Operation and Maintenance Instructions



VIBRATORY FEEDERS

**MODELS 58B, 62B,
65B, 70B & 75B**

ERIEZ WORLD HEADQUARTERS: 2200 ASBURY ROAD, ERIE, PA 16506-1402 U.S.A.
WORLD AUTHORITY IN SEPARATION TECHNOLOGIES

Introduction

This manual details the proper steps for installing, operating and maintaining the Eriez Vibratory Feeder.

Careful attention to these requirements will assure the most efficient and dependable performance of this equipment.

If there are any questions or comments about the manual, please call Eriez at 814-835-6000 for Vibratory Feeder assistance.



CAUTION

Safety labels must be affixed to this product. Should the safety label(s) be damaged, dislodged or removed, contact Eriez for replacement.

Table of Contents

ERIEZ VIBRATORY FEEDER - MODELS 58B, 62B, 65B, 70B & 75B

INSTALLATION	4
Mounting	4
Electrical Connections	5
OPERATION AND MAINTENANCE	6
Adjustment (Tuning)	6
Adjustment (Tuning) Guide	6
How To Measure Displacement	7
Tuning for Non-standard Trays	7
Adjustment or Tuning for Various Densities of Material	8
REPAIRS	8
Coil Replacement	8
Spring Change or Replacement	9
58B Feeder	9
62B and 65B Feeders	10
70B and 75B Feeders	10
TROUBLESHOOTING	11
PREVENTIVE MAINTENANCE	11
STORAGE OF EQUIPMENT	11



Installation

Mounting

These Eriez heavy duty Feeders may be mounted in any of the following ways:

Suspension Mounting

Suspend front and rear of Feeder from cables attached to the suspension bracket eyebolts. Refer to Table 1 for suspension cable size. Cables should be minimum 3/8" (10 mm) dia. standard. Safety cables are also recommended for suspension mounted feeders.

Refer to Eriez Vibratory Feeders Hopper Transition and Installation Guide for additional information. (VM-3320)

TABLE 1 Suspension Cable

Feeder Model	Rear Suspensions	Max Safe Working Loads	Front Suspension	Max Safe Working Loads
52A	3/8" cable	1.0 ton	1/4" cable	.45 ton
58B	3/8" cable	1.0 ton	1/4" cable	.45 ton
62B	3/8" cable	1.0 ton	1/4" cable	.45 ton
65B	3/8" cable	1.0 ton	1/4" cable	.45 ton
70B	3/8" cable	1.0 ton	5/16" cable	.75 ton
75B	3/8" cable	1.0 ton	5/16" cable	.75 ton

! WARNING

Suspension mounting inherently involves risk of property damage or personal injury to equipment or personnel located under or near the machine, should a mounting cable fail. Suspension component specifications given in this manual are suggestions only, and *final selection of suspension method is entirely the responsibility of the user.* Select and use suspension cables with rated capacities (including reduction factors for clamps, etc.) that provide adequate safety factors when the weight of the equipment and all possible loading conditions and upsets are taken into account. Consult Eriez at 814-835-6000 if additional Eriez equipment information is needed to make this selection. As with all suspended equipment, access to the area under the machine should be restricted.

NOTE: Do not suspend from eyebolts threaded horizontally into the tray or drive housing. Eyebolts loaded at right angles to their shanks may fail unexpectedly causing damage to equipment or personal injury.

Floor Mounting

Mount front and rear of Feeder on the floor mounting accessories provided as an alternate to the suspension accessories. The mounting bases (Part #27 or #28) should be bolted to the floor or other mounting surface, and the unit, with the floor mounting springs (Part #24, 25, or 26 on part list), simply placed on the bases (no fastening necessary). (See Figure 1)



FIGURE 1

Combined Suspension and Floor Mounting

Any combination of suspension and floor mounting means may be utilized. The details of any such combination will, of course, be dictated by the particular application. The instructions given above should be followed.

IMPORTANT NOTE:

Special Trays and Attachments

Eriez engineering service should always be consulted before undertaking the design or construction of special trays. Neither standard nor special trays as furnished by Eriez Magnetics should be modified or attachments made without first consulting us. (See Eriez Standard Tray Specifications.) **Unauthorized alterations void Eriez' warranty.**



Electrical Connections

NOTE: The Eriez Vibratory Feeder is designed to be operated from an AC source. It cannot be operated from a DC source.

All wiring should conform to all applicable electrical codes.

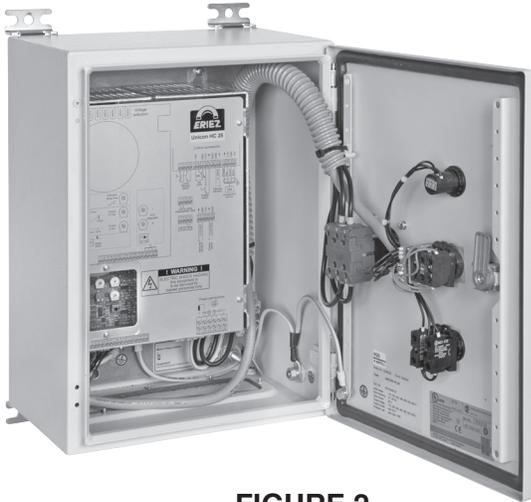

FIGURE 2
Eriez Feeder Control

1. Refer to the schematic and outline drawing and Instruction Operation Manual for the specific Eriez control operating your feeder.
2. Check the specifications of the power line to be certain that they are the same as those shown on the nameplate of the Feeder and Control.
3. Caution: The cable between the feeder and control must be of sufficient size for the current and voltage as indicated on the equipment name tag. A voltage drop through a cable of insufficient size for the required distance may result in reduced feeder displacement while operating.
4. On multiple-drive feeders (two or more drives on one tray) all drives should be wired electrically in phase. The black wires from each power cord should be connected together and the white wires connected together. The black wires should be connected to the positive side of the single-phase input voltage and the white wires should be connected to the negative side.

You are now ready to start your vibratory feeder.

! CAUTION

Operation from portable engine driven power plants.

Varying and unstable line frequency has an adverse effect on vibratory feeders because they are tuned mechanical devices, designed around either 50 or 60 cycle operating frequency. Shifts in the operating point due to changes in frequency (+or-1 cycle) cause higher than normal spring stress, striking and high line currents which can cause drive and tray failure. When operating from portable engine-driven power plants, be certain that the engine is up to speed and all other loads are started and at running speed before starting the feeder.

The feeder should always be stopped first when the engine-driven power plant is shut down.

Operation

To start the Vibratory Feeder after all connections have been made, turn the switch on the control to the "ON" position and adjust the feed rate by rotating the control knob. **Do not operate the unit with any associated equipment touching any part of the unit.**

No routine maintenance or lubrication is required, except that any accumulation of foreign matter should be periodically removed from between the tray and the body to prevent restriction of movement of the vibratory elements.

Adjustment (Tuning)

Eriez feeders, when shipped from the factory with a tray, are tuned and require no further adjustment. However, if tray is to be attached in the field or replacement liners installed, etc.. final tuning may be required. In this instance the instructions outlined below should be followed:

This unit is adjusted by changing the stiffness of the springing system. Spring stiffness adjustment consists of varying the number of springs (Part 8, on part list) at the back of the unit or the thickness of individual springs. Access to the rear springs is gained by removing the cover (Part 6, on part list) at the back of the unit (see Figure 3). In tuning, the front springs need never be disturbed. In NORMAL OPERATION at full voltage with the unit fully warmed up, the displacement of the tray, measured at the back of the tray or the tray mounting brace is .065" – .070" (1.65 – 1.78 mm) for 58B, 70B and 75B; .055" – .060" (1.4 – 1.5mm) for 62B and 65B. Excessive displacement will result in noisy operation of the unit and may, if continued, cause damage to components.

CAUTION

(Please Read Carefully): Only those feeder trays approved by Eriez are acceptable under the limits of our warranty. Any modifications, alterations, or changes of any degree must be approved by the Eriez Manufacturing Co. This is a tuned device and the correct tray must be applied to the motor drive for which it is tuned. NEVER OPERATE THE UNIT IN A STRIKING CONDITION!

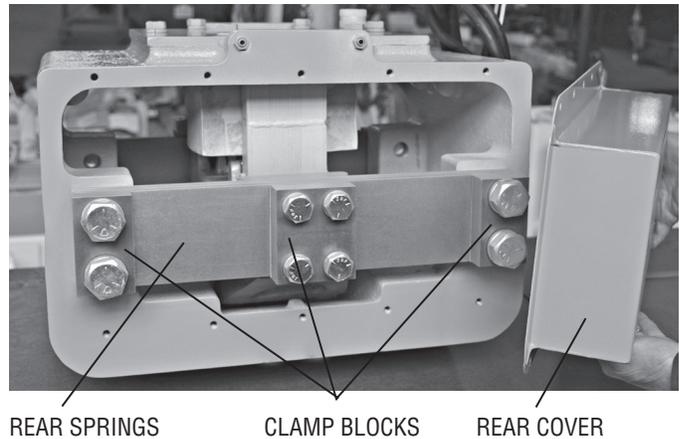

FIGURE 3

Adjustment (Tuning) Guide

The following general rules should be kept in mind when making adjustments:

1. To **increase** the tray displacement, **decrease** the stiffness of the spring system.
2. To **decrease** the tray displacement, **increase** the stiffness of the spring system.

The above rules are true where the unit is operating on the normal side of its tuning curve. If increasing or decreasing the spring stiffness has an effect opposite to that noted in (1) or (2) above, it means that the mass of the tray and/or load has been great enough to throw the operating point to the reverse side of the curve, which is undesirable. In this event, the stiffness should be increased (or the tray-load mass reduced) until the behavior is in accordance with rules (1) and (2) above. The unit can then be properly tuned.

Normally spring thicknesses of 5/16", 1/4" 3/16" and 1/8" (7.9, 6.4, 4.8, and 3.2 mm) are used. To serve as a guide in tuning, the following spring stiffness figures should be used: 1/4" (6.4 mm) thick spring is approximately 53% as stiff as a 5/16" (7.9 mm) thick spring; 3/16" (4.8 mm) thick spring is approximately 44% as stiff as a 1/4" (6.4 mm) thick spring; and a 1/8" (3.2 mm) thick spring is approximately 30% as stiff as a 3/16" (4.8 mm) thick spring.

Example: to slightly increase the deflection of a unit a 1/4" (6.4 mm) thick spring could be removed and replaced with two 3/16" (4.8 mm) thick springs. Or, to slightly decrease the deflection of a unit, a 5/16" (7.4 mm) thick spring could be removed and replaced with two 1/4" (6.4 mm) thick springs. These combinations must be determined by the existing springs on the rear spring stack.



How To Measure Displacement

With the unit operating, observe where the fine gray lines on the displacement sticker meet. This point will be higher or lower as the displacement changes. Opposite the point where they meet, read amount of displacement.

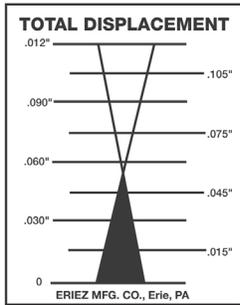

Stroke gauge under vibration (shown at .055" displacement)

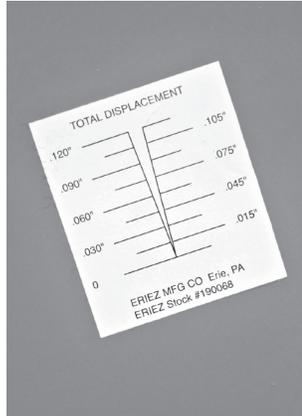

FIGURE 4

Tuning with New Tray

In the adjustment of the unit, the following steps should be followed:

1. Attach the tray (Part 12, on part list) and draw all bolts tight. Tray mounting studs - the nuts are torqued per Table 2. Check air gap (See Items 8 and 9 under Coil Replacement.)
2. Energize the unit at the voltage and frequency shown on nameplate.
3. If a control box is used, turn potentiometer from 0% to 100% slowly and observe the unit in operation.
 - a) If a hammering noise is in evidence, the tray displacement is excessive.

To produce normal quiet operation, increase the stiffness of the rear spring stack by substituting a spring of greater thickness for one or more of the rear springs, or by adding additional springs until the displacement is approximately .065" – .070" (1.65 – 1.78 mm) for 58B, 70B and 75B; .055" – .060" (1.4 – 1.5mm) for 62B and 65B. Additional springs may be purchased from Eriez (see Parts List Part 9). Under normal operating conditions, the unit may be turned "ON" or "OFF" quickly without any momentary or prolonged striking noise.

b) If the displacement so measured is considerably less than .065" – .070" (1.65 – 1.78 mm), decrease the spring stiffness by substituting springs of lesser thickness. If the displacement is much more than .065" – .070" (1.65 – 1.78 mm), increase the spring stiffness by substituting springs of greater thickness.

In changing tuning springs, put the clamp blocks (Parts 9 & 10, on part list) back on the same way they came off (see Figure 3) to ensure smooth clamping surfaces against the springs. All clamping bolts (Part 19) should have a thread engagement of not less than one and one-half times the bolt diameter and should be drawn very tight (see Bolt Torque Information below on Table 2). If "bottoming" of bolts should occur, washers of sufficient thickness to prevent such "bottoming" should be used under the bolt heads.

To insure proper clamping pressure, threads should be lightly coated with a good molybdenum disulfide anti-seize compound.

KEEP COMPOUND OFF OF CLAMPING SURFACES.

TABLE 2. Tray Mounting Studs and Spring Clamping Bolts

Feeder Size	Bolt Size Torque Value									
	1/2 - 13		5/8 - 11		3/4 - 10		7/8 - 9		1 - 8	
58B	55 ft lbs	75 Nm								
62B, 65B			150 ft lbs	200 Nm			340 ft lbs	460 Nm		
70B, 75B			150 ft lbs	200 Nm	265 ft lbs	360 Nm	340 ft lbs	460 Nm	365 ft lbs	490 Nm

Operation (cont.)

Adjusting or Tuning For Various Densities of Materials

The unit may be adjusted to provide optimum performance for a specific density of material in the same manner as described for non-standard trays. When units are adjusted with the tray empty to a displacement of .065" – .070" (1.65 – 1.78 mm) (all standard tray units are so adjusted at factory). They are set for optimum performance on a material with a density of 100 lbs/cu ft. (1.6 g/cc) For very light materials, optimum performance occurs with displacements above this value (up to .065" (1.7 mm)). For denser materials, optimum performance occurs with displacements less than .065" – .070" (1.65 – 1.78 mm).

The basic characteristic of these units is such that the volume output is virtually constant for materials from 40 lbs/cu ft to 125 lbs/cu ft (.65 g/cc to 2 g/cc) when units are equipped with standard trays. When non-standard trays are used (particularly large trays), a tuning change is often necessary to provide optimum performance for a specific material.

Repairs

Coil Replacement

The electrical assembly in a vibratory Feeder may require replacement due to operation at over-voltage, or normal aging of the unit. Re-assembly will require checking and possible re-centering of the air gap between the E-frame and the permanent magnet elements. The air gap is directly accessible from the outside of the unit as described below.

The following procedure should be followed in removing and replacing the electrical assembly (see Figures 5 & 6).

1. Remove the bolts securing the electrical assembly plate to the body casting.
2. Back off the adjusting screws that position the electrical assembly plate.
3. Pry and lift the electrical assembly from the body casting, using a sling or some other safe method of lifting. (See Figure 6).
4. Replace defective electrical assembly (order from Eriez Parts List).

5. In replacing the electrical assembly, insert it into its original position in the body casting. **DO NOT FORCE THE ASSEMBLY INTO PLACE.** When properly aligned, the assembly will go in easily, although there will be a distinct pull exerted by the permanent magnets in the armature. To overcome this pull, it may be necessary to guide the plate with a heavy screwdriver, meanwhile applying pressure to the top of the plate.

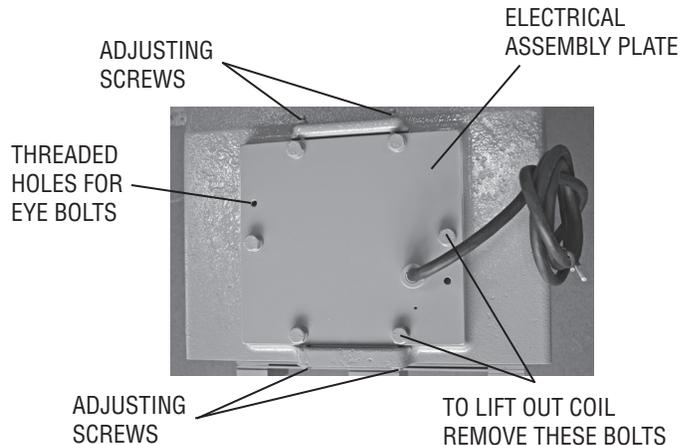

FIGURE 5

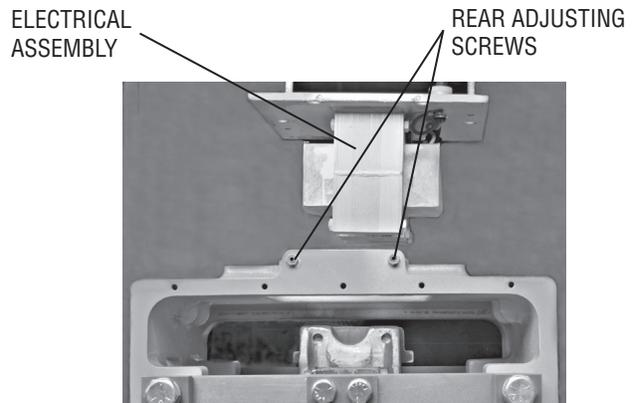
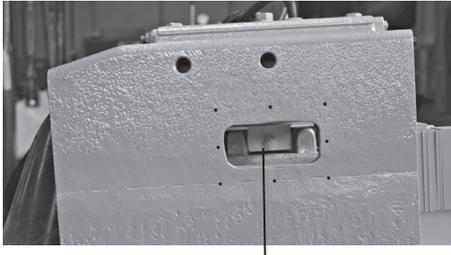

FIGURE 6

6. Start the electrical assembly plate bolts into the body casting, tighten bolts and back off 1/4 – 1/2 turn.
7. Tighten the adjusting screws that position the electrical assembly plate.
8. Remove the nameplate from the side of the body casting to gain access to air gap. (See Figure 7).
9. Working through the opening in the side of the body casting (Figure 7) and using a non-magnetic feeler gauge (furnished with each unit), approximately .072" (1.8 mm) thick (.090" (2.3 mm) thick for Model 58B) check the air gaps between the E-Frame legs and the armature pole pieces.

These gaps should be uniform in width and parallel and as nearly alike as possible. If they are not, they should be adjusted by shifting the electrical assembly plate with the front or rear adjustment screws. In checking the gaps, the internal parts will be easier to see if the rear cover (Part 6) is removed.



ACCESS PORT (FOR AIR GAP ADJUSTMENT)

FIGURE 7

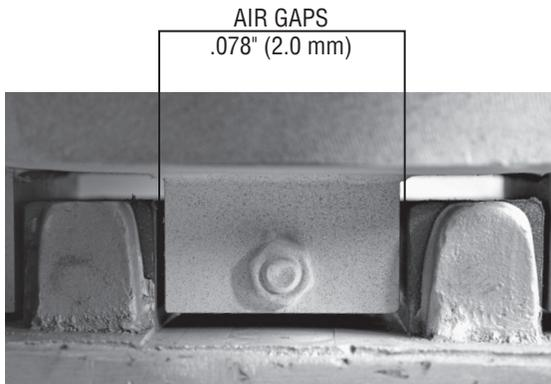

FIGURE 8

10. Tighten the electrical assembly plate bolts and replace the cover nameplate.

Spring Change or Replacement

Although the metallic leaf springs have outstanding life characteristics, failure may eventually occur, especially if the displacement is greater than normal. The symptoms of such failure are:

1. Erratic behavior of the unit,
2. Greatly reduced displacement and
3. Greatly increased and perhaps uncontrollable displacement.

If spring failure is suspected, the front and rear spring stacks should be removed, checked and replaced one stack at a time. Replace broken or cracked springs with springs of equal thickness.

NOTE: Fractures in springs are not always visible. Tapping springs to obtain distinctive ring ensures no fractures present. If sound is dull replace spring as it has fractures.

58B Feeder

Replacement of front springs

Requires complete disassembly of the unit.

1. Remove coil assembly through top of unit. Six hex bolts hold coil mounting plate in place.
2. Remove rear sheetmetal cover and rear spring attaching bolts, spring clamps and spacers. Change rear springs if required.
3. Remove diaphragm clamp and rubber diaphragm from front of unit.

CAUTION: Tray mounting pads are special flat washers and must be reassembled at same stud locations as disassembled.

4. Remove outer spring bolts, spring clamps and spacers and remove armature, with spring stack attached, out through front of unit.
5. Remove center spring attaching bolts, spring clamps and spacers. Replace front springs and reassemble by reversing above procedure.
6. Torque all spring bolts to Table 1 values.

Replacement of rear springs

Will not require complete disassembly of the unit.

1. Remove rear sheetmetal cover.
2. Remove rear spring attaching bolts, spring clamps, spacers and springs.
3. Replace springs and reassemble by reversing above procedure.
4. Torque all spring bolts to Table 2 values.

Repairs (cont.)

62B and 65B Feeders

Replacement of front springs

1. Remove diaphragm clamp and rubber diaphragm from front of unit.

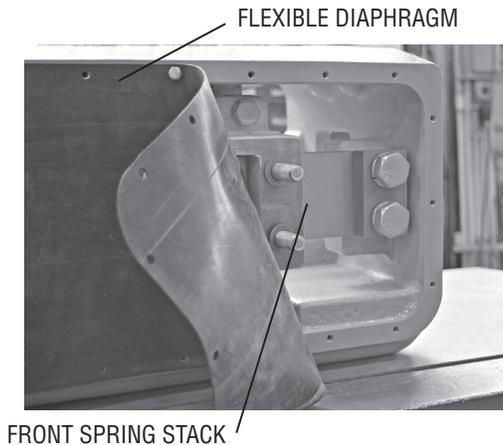

FIGURE 9

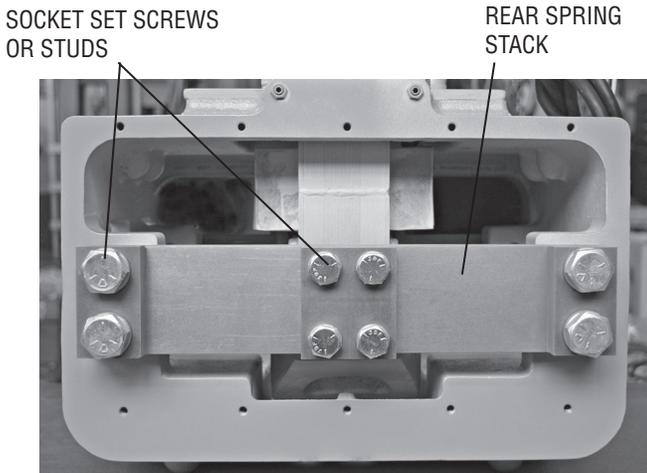

FIGURE 10

2. Remove inner tray clamp attached to armature.
CAUTION: Tray mounting pads are special flat washers and must be reassembled at same stud locations as disassembled.
3. Remove spring bolts, spring clamps, spacers and springs.
4. Replace springs and reassemble unit by reversing above procedure.
5. Torque all spring bolts as follows: outer bolts - Table 2 values.

Replacement of rear springs

1. Remove rear sheetmetal cover.
2. Remove rear spring bolts, spring clamps, spacers and springs.
3. Replace springs and reassemble entire unit by reversing above procedure.
4. Torque all spring bolts per Table 2.

70B And 75B Feeders

Replacement of front springs

1. Remove diaphragm clamp and rubber diaphragm from front of unit.
2. Remove inner tray clamp attached to armature.
CAUTION: Tray mounting pads are special flat washers and must be reassembled at same stud locations as disassembled.
3. Remove top bolts from the three spring clamp locations.
4. Insert dowel pins (threaded on one end) into same three hole locations. Thread size for outer holes is 1-8 UNC and center hole is 3/4-10 UNC. See Figure 10.
5. Remove remaining spring bolts, spring clamps, spacers and springs.
6. Replace springs and reassemble unit by reversing above procedure.
7. Torque all spring bolts per chart on page 7.

Replacement of rear springs

1. Remove rear sheetmetal cover.
2. Remove top bolts from the three spring clamp locations.
3. Insert dowel pins (threaded on one end) into same three hole locations. Thread size for outer holes is 1-8 UNC and center hole is 3/4-10 UNC. See Figure 10.
4. Remove remaining spring bolts, spring clamps, spacers and springs.
5. Replace springs and reassemble entire unit by reversing above procedure.
6. Torque all spring bolts per Table 2.

Troubleshooting

1. Feeder Not Operating

- a. Check fuses.
- b. Check input voltage.
- c. Check output voltage and current (amps).
- d. If voltage is going to feeder coil, check coil for open or ground.

2. Slow Output Of Feeder

- a. Check current on feeder at 100% voltage with the tray empty. If current is higher than nameplate reading, check for broken tuning springs.
- b. Check for broken tray mounting studs.
- c. Check for cracked welds and cracks in the tray.
- d. Check for worn tray or liner.
- e. If tray is enclosed, the booting to the inlet and outlet must be flexible, as not to restrict tray movement.
- f. Check air gap.

3. Feeder Is Noisy

(metal-to-metal striking sound)

- a. Check for broken isolation coil springs (suspended or floor mount).
- b. Is the tray rubbing on a hopper, chute work or anything else in the area.
- c. Check air gap per manual.
- d. Check current on feeder at 100% voltage with the tray empty. If the current is higher than the nameplate reading, then check for broken tuning springs.

Preventive Maintenance

1. Check suspension, and keep feeder clear of hopper and all other objects.
2. Check for build-up of product in the tray.
3. Check deflection.
4. Check current on feeder (should be within nameplate rating).
5. Check liners in tray for wear and loose bolts. If liner is to be replaced, use same thickness material.

Storage of Equipment

Prior to storage, equipment should be carefully inspected for shipping damage. Should damage have occurred, immediately contact freight carrier and Eriez Manufacturing. Equipment should remain in its original shipping crate or packaging and be placed in a clean, dry area.

For electronic controllers, in addition to the above, a rust inhibitor should be placed inside the control enclosure. Desiccant must be removed from control enclosure prior to wiring control. Controls should not be stored in temperatures above 110°F (43°C).

Eriez and Eriez Magnetics are registered trademarks of Eriez Manufacturing Co, Erie, PA

©2019 Eriez All Rights Reserved



World Authority in Separation Technologies

Headquarters: 2200 Asbury Road, Erie, PA 16506-1402 U.S.A.

Telephone: 814-835-6000 • Fax: 814-838-4960

www.eriez.com e-mail: eriez@eriez.com



Manufacturing Facilities: AUSTRALIA • BRAZIL • CANADA • CHINA • INDIA • JAPAN • MEXICO • SOUTH AFRICA • UNITED KINGDOM • UNITED STATES