



Protecting Pets with Magnetic Separation Technologies

By: Chris Ramsdell,
Eriez Product Manager – Separation



Eriez Model U Magnetic Traps



Eriez Model B Magnetic Traps

People all around the world consider their pets as a cherished part of the family. That is why it should be no surprise that pet food ingredients undergo the same stringent quality checks as food manufactured for humans. Many of the world's largest pet food producers rely on Eriez magnetic separation equipment to ensure their end-product is free of metal contamination which could be extremely harmful to pets.

Metal contamination creates an impure pet food product that must be rejected. This metallic contamination can come from a variety of sources. For example, incoming products sometimes contain contaminants from the transportation vehicle used to deliver the product, such as a tanker truck or railcar. Contamination can originate within the plant due to material processing, grinding or general abrasion. Fortunately, ferrous metal contamination problems can be reduced or eliminated by using magnetic separation equipment. State-of-the-art magnetic separators are available in a wide variety of designs to remove ferrous material such as nails, rust, scale, hardware and other contaminants from both dry and liquid food products.

This article discusses how magnetic separation equipment is applied in pet food facilities to produce a safer, higher-quality product

Liquid Line Magnetic Separators

For low-viscosity ingredients that flow freely, Eriez recommends Model B-Traps. These separators utilize a set of cantilevered rare earth tube magnets inserted into a cast stainless steel sump body. As the product weaves through the magnetic tubes, ferrous contaminants attach to the tubes. The powerful rare earth magnetic circuit holds onto these materials until the unit is cleaned.

For high-viscosity products like meat emulsions and final wet food products, the Eriez Model U-Trap is the preferred magnetic separator. The high-strength rare earth plate magnet is mounted to the bottom of a cast housing where it does not impede product flow. The U-Shape housing construction forces the product to come in close contact with the plate magnet which attracts and holds any ferrous contaminants until an operator cleans it off.

Simmons Pet Food has five pet food production facilities in North America that produce more than 3,500 unique SKUs. At their wet pet food facility in Mississauga, Ontario, Simmons installed several U-Traps to serve as a quality check for final wet food products. These units are installed



on 4" lines downstream of a mixing tank and emulsifier, immediately upstream of their metal detectors. With this equipment arrangement, metal detectors focus on identifying any non-magnetic metals that may be present in the product. The U-Traps remove ferrous metal contaminants upstream of the metal detectors, reducing the amount of product rejected by the metal detectors. According to Maintenance Manager Kenn Jones, these traps reliably recover ferrous fines 2-3 mm in size and have helped Simmons increase total product yield while maintaining high quality standards.

Dry Bulk Ingredients

For dry ingredient applications with higher throughput requirements, Eriez suggests incorporating Magnetic Drums-In-Housing to remove ferrous contaminants. Drum magnets are commonly installed to process pet food ingredients like corn, grains, chicken/turkey meals, dry vegetables and beet pulp. These units are typically placed near the beginning of the process where most of these bulk ingredients are unloaded from rail cars and trucks before further processing. Magnetic drums can also be installed at the end of the process to provide a quality check on dry bulk kibble.

Drum magnets are self-cleaning magnet assemblies that continuously remove ferrous contaminants from a product flow. The magnet assembly is enclosed within a stainless-steel drum and fixed in position. The drum shell rotates around the magnet, conveying the material through the magnetic field. The clean (non-magnetic) material cascades off the drum face on its normal trajectory while the magnetic material is drawn around the drum and discharged at the bottom. Magnetic drums designed with ceramic magnet circuits are ideal for removing relatively large ferrous objects from a dry product flow, while rare earth magnetic circuits are utilized to remove very fine or weakly magnetic contamination.

For lower throughput applications, Eriez recommends Magnetic Grates-In-Housing. These units, usually installed in vertical chutes, can be supplied with one or multiple rows of magnetic grates with staggered permanent magnetic tubes to capture ferrous contaminants. Dry ingredients entering the housing are forced to weave through the staggered magnetic tubes, effectively removing everything from hardware to metal shavings. Eriez Rare Earth Magnetic Grates-In-Housing can remove contaminants as small as fine ferrous dust and scale. They are suitable for processing fine, free-flowing ingredients such as milled grains and pet food powders.

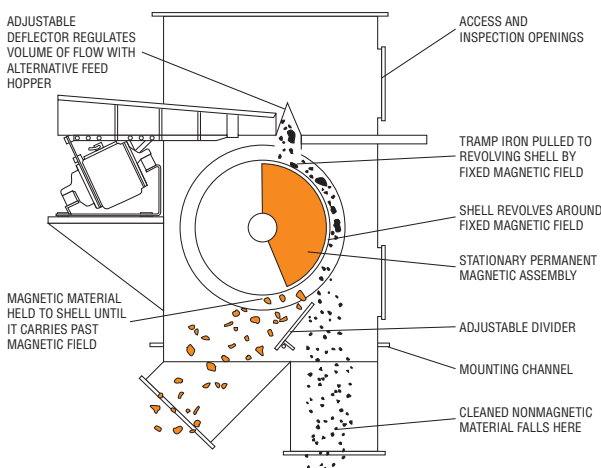

Eriez Model HFP Magnetic Drum-In-Housing



Eriez Manual Easy-To-Clean Magnetic Grate-In-Housing



**Eriez Automatic Easy-To-Clean
Magnetic Grate-In-Housing**

The simplest versions incorporate a single-layer magnetic grid and are used inside a hopper so that raw materials must pass through the grates as material feeds from the hopper. Multiple row units improve separation effectiveness. Grate-housing designs may include a standard grate that can be removed from the housing for manual cleaning. An easy-to-clean grate design enables push/pull operation to strip accumulated tramp metal from the grates without physically handling the magnet. Eriez also offers an Automatic Easy-To-Clean model which uses a set of pneumatic cylinders to automatically discharge tramp metal from the magnetic grates with the push of a button or timer control.

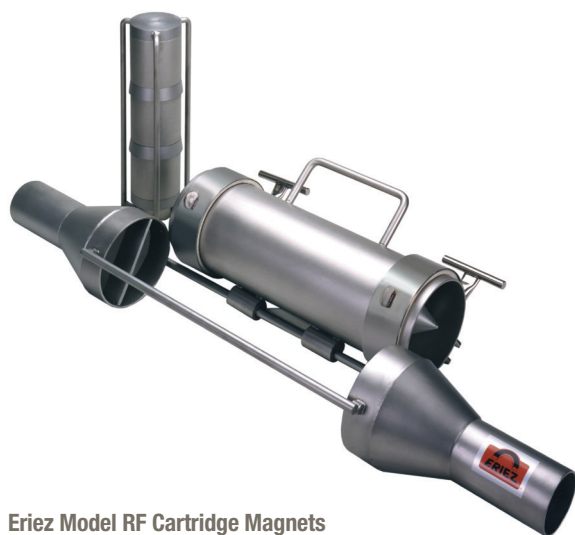

Eriez Model RF Cartridge Magnets

Pneumatic Line Magnetic Separators

Many dry ingredients are brought into processing facilities from trucks or railcars via air conveyance. This is where the Eriez Model RF (Radial Field) Cartridge comes in. When a truck or train car pulls into the material unloading area and pneumatic lines are used to transfer the incoming material into the plant, Eriez RF Cartridges are often installed on the other side of building/wall to safeguard against metal entering the plant.

As material enters the RF Cartridge inlet, it contacts a fixed nose cone, forcing the material to the outside walls of the housing. The material then cascades around a cylindrical magnetic element and ferrous contaminants attract and attach to the magnet's collection points. For cleaning, an operator can easily remove magnetic element and wipe it off with a gloved hand or rag. This unit is designed for installation in 3" - 6" lines (25psi Positive Pressure / -10psi Vacuum).

About Eriez®

Established in 1942, Eriez is a global leader in separation technologies. Our commitment to innovation has positioned us as a driving market force in several key technology areas, including magnetic separation, flotation, metal detection and material handling equipment. The company's 900+ employees are dedicated to providing trusted technical solutions to the mining, food, recycling, packaging, aggregate and other processing industries. Headquartered in Erie, Pennsylvania, USA, Eriez designs, manufactures, and markets on six continents through 12 wholly owned international subsidiaries and an extensive sales representative network. For more information, visit www.eriez.com.